

Overview of the development and application of wind energy in New Zealand

Zhiguo Zhang^{a,b}, Xiran Liu^b, Dan Zhao^{b,*}, Scott Post^c, Jiasen Chen^b

^a School of Mechanical and Energy Engineering, Zhejiang University of Science and Technology, Hangzhou, 310023, China

^b Department of Mechanical Engineering, College of Engineering, University of Canterbury, New Zealand

^c Department of Aerospace Engineering, College of Engineering, Embry-Riddle Aeronautical University, ,FL, USA

ARTICLE INFO

Keywords:

Renewable energy
Wind energy
Energy storage technologies
Small-scale wind turbines

ABSTRACT

The restructuring of the energy industry is imperative, as New Zealand strives to reduce greenhouse gas emissions. New Zealand has abundant renewable energy resources, and about 85% of current electricity generation is from renewable energy sources. However, in recent years, it appears that a considerable fraction of wind energy has been underutilized. This article reviews the history, current status, and future trends of wind energy development in New Zealand. The main challenges to the current development of wind energy are summarized compared to other countries. The main challenges come from the bi-cultural influence, environmental influence, and economic and social influence due to the variable nature of wind power, it is critical to store and operate power safely and reliably during peak power generation periods. This article compares seven mainstream wind energy storage technologies and analyzes the best solution for wind energy storage in New Zealand. This article analyzes the feasibility of using small-scale household (standard power rating range from 0.004 to 16 kW) wind turbines in New Zealand cities regarding their construction and operation process. The life cycle and the maximum capacity coefficient of such small-scale wind turbines are overviewed via three case studies and later compared with large commercial wind turbines (standard power rating ranges from 1 to 3 MW) in power generation capacity. It has been found that small-scale household wind turbines have notable power generation potential and economic benefits in the long term.

1. Introduction

The energy demand grows day by day as the global population expands and manufacturing demands increase. Therefore, non-renewable traditional fossil fuels will not be able to meet the world's energy demand in the future [1]. The development and utilization of new energy sources have become an essential issue for the sustainable development of modern society. Various countries have been actively promoting renewable energy-related industries in recent years, including energy conservation and emission reduction, energy supply security, and employment. As one of the important alternatives to fossil fuels, the development of wind energy has also attracted much attention [2]. New Zealand has also made great strides in generating electricity from renewable energy sources (RES) as of 2020, ranking third among the leading countries in the Organization for Economic Co-operation and Development (OECD), which has over 30 member countries around the world [3].

However, New Zealand is facing two significant challenges. The first is to search for the energy required to power the economy, and the second is the transition to a more sustainable energy future. New Zealand

government considers that renewable energy will play a more important role in the global energy structure in the future. At present, the New Zealand government has adopted a series of policies to promote the development of renewable energy, including the goal of substantially increasing the proportion of electricity generated by hydro, geothermal, and wind energy [4]. Renewable energy is being promoted in New Zealand and now accounts for approximately 85% of the total electricity generated [5]. Unique geographical location and climatic conditions have led to the diversification of New Zealand's energy resources. Large areas of forestry and agriculture provide a good source of biofuels while also owning an abundance of tidal energy due to facing the ocean. Solar energy has been relatively slow to develop but has taken its place in New Zealand's current energy structure. Hydropower and geothermal power developments are generally the dominant projects in New Zealand, and the country's leading source of electricity has always been hydropower [3]. As a clean energy source, the geothermal resource can be captured directly by the heat-carrying fluid and used to generate electricity [6]. New Zealand's wind energy resources are equivalent to the best resources in the world. Although New Zealand has lagged behind

* Corresponding author:

E-mail address: dan.zhao@canterbury.ac.nz (D. Zhao).

<https://doi.org/10.1016/j.enbenv.2022.06.009>

Received 21 April 2022; Received in revised form 16 June 2022; Accepted 28 June 2022

Available online 3 July 2022

2666-1233/Copyright © 2022 Southwest Jiatong University. Publishing services by Elsevier B.V. on behalf of KeAi Communication Co. Ltd. This is an open access article under the CC BY license (<http://creativecommons.org/licenses/by/4.0/>)

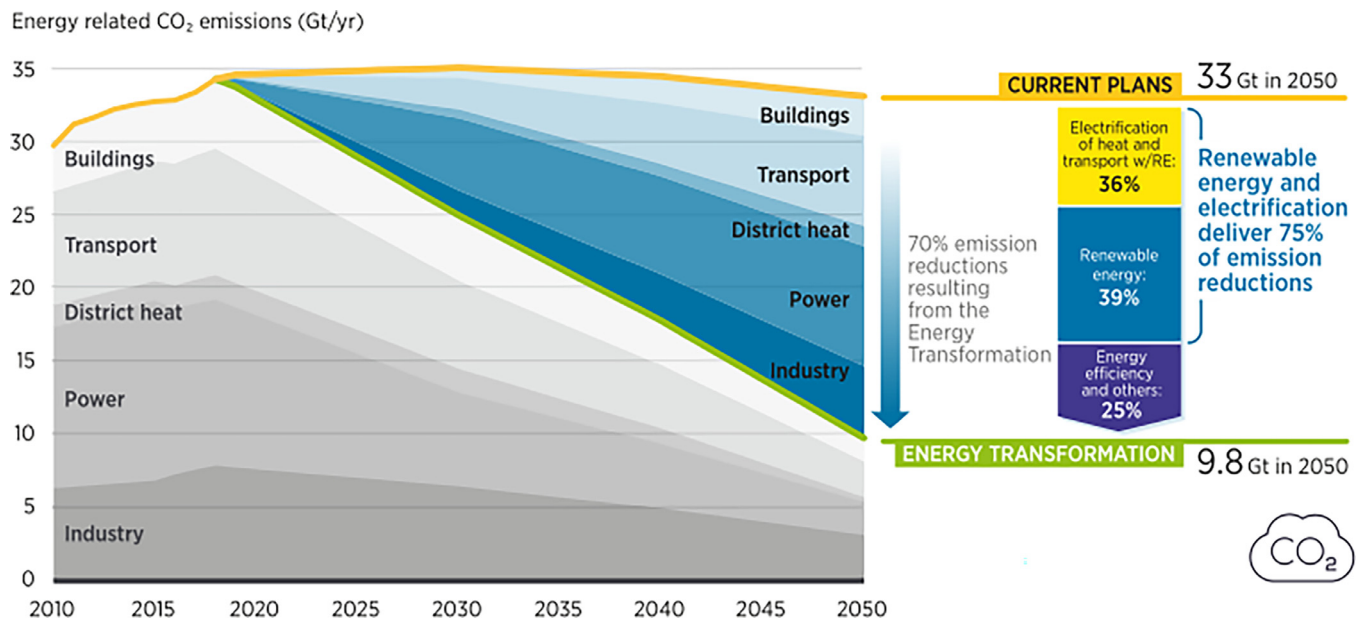

Fig. 1. Renewable energy and efficiency measures may provide more than 90% of the necessary CO₂ reductions in 2050, driven by substantial electrification [8].

many countries in the field of wind energy development, it is undeniable that wind energy is growing rapidly and has become an integral part of New Zealand's modern energy structure [3–5].

Wind energy is one of the most commercially promising and dynamic renewable energy sources, clean to use and relatively low in cost. There is plenty of room for growth in installed wind power capacity. While providing a stable supply of electricity for economic growth, wind power can effectively mitigate air pollution, water pollution, and global warming. Due to its geographic location and terrain, New Zealand has a consistent and rich wind resource. The presence of central mountain ranges, particularly on the South Island, and the continuous coastline with many sites exposure to the sea breeze provide wind energy. Winds in the mountains are typically more stable than winds in other areas of the country [7]. The long-run average net capacity factor across all current and potential sites in New Zealand is 40% (with 35% and 45% in autumn and spring, respectively). Wind energy is an under-explored but inexhaustible resource with tremendous potential value in New Zealand [5].

The remainder of this article is as follows: Section 2 briefly overviews the renewable resources, energy statistics in New Zealand, and global wind energy development. Section 3 presents the wind energy resource, current development status in New Zealand, and related policies and institutional settings. Section 4 discusses the main challenges to the development of wind power in New Zealand, while Section 5 considers the reliability and feasibility of promoting small wind turbines in New Zealand. Moreover, a related case study is included. Section 6 provides the conclusion. This article aims to provide a platform for the near future development of wind energy in New Zealand.

2. New Zealand renewable energy background

2.1. Importance of renewable resources

How to deal with climate change has become the main concern of this century. According to the Paris Agreement, global temperature rise should be limited to well below 2 °C. The ideal scenario is to limit warming to 1.5 °C compared to pre-industrial levels in this century. To meet the Paris Agreement targets, energy-related carbon dioxide (CO₂) emissions need to be reduced by around 3.5% per year from now until 2050 and continue to be reduced afterwards. As shown in Fig. 1, the transition

in energy use to electrified forms of transport and heat, together with an expansion of generation from RES, may achieve the required reduction in energy-related CO₂ emissions of around 60% by 2050. This share may increase to 75% when additional reductions in direct renewable energy use are taken into account. Moreover, when energy efficiency is increased, this share may increase to greater than 90%, thus enabling the world to reach the targets set in the Paris Agreement [8].

At present, most of the energy consumed in the world comes from fossil fuels (e.g., coal, oil, natural gas, etc.), and burning fossil fuels is the main cause of greenhouse gas and other air pollutant emissions. Fossil fuel is a non-renewable energy source and has limited availability. The use of fossil fuels to generate electricity also generates toxic waste, which causes air pollution, water pollution, and degrades the habitat of plants and animals and the global climate. In contrast, renewable energy sources are naturally formed and harvested repeatedly from the environment. The use of renewable energy has many benefits, such as proactively addressing stringent environmental requirements, diversifying fuel sources, ensuring a secure and stable energy supply, and promoting employment and regional economic development [9]. Aydoğan and Vardar [10] investigated the CO₂ emissions of Emerging 7 (E7) countries (including China, India, Brazil, Russia, Mexico, Indonesia, and Turkey) from 1990 to 2014 and found a positive relationship between CO₂ emissions and real Gross Domestic Product (GDP), non-renewable energy consumption. In addition, there was a negative relationship between CO₂ emissions and the square of real GDP and renewable energy consumption. Therefore, the share of renewable energy should be increased to reduce fossil energy consumption in terms of environmental improvements.

Fig. 2 depicts the primary energy consumption by fuel (on the left) and shares of primary energy (on the right) from 1965 to 2035 on a global scale. By 2035, the global primary energy consumption by fuel is expected to reach 17 billion tonnes of oil equivalent (Btoes), of which the oil, gas, and coal together account for more than 75% of the total energy supply, compared to 86% in 2015. In addition, the global energy demand will keep increasing by around 30% by 2035, with an average annual growth rate of 1.3% [11]. There is also evidence that among the different sources of energy, the high consumption of non-renewable energy sources (e.g., oil, carbon, and natural gas) determines the production of capital goods, which drives the competitiveness of the goods in the market [12].

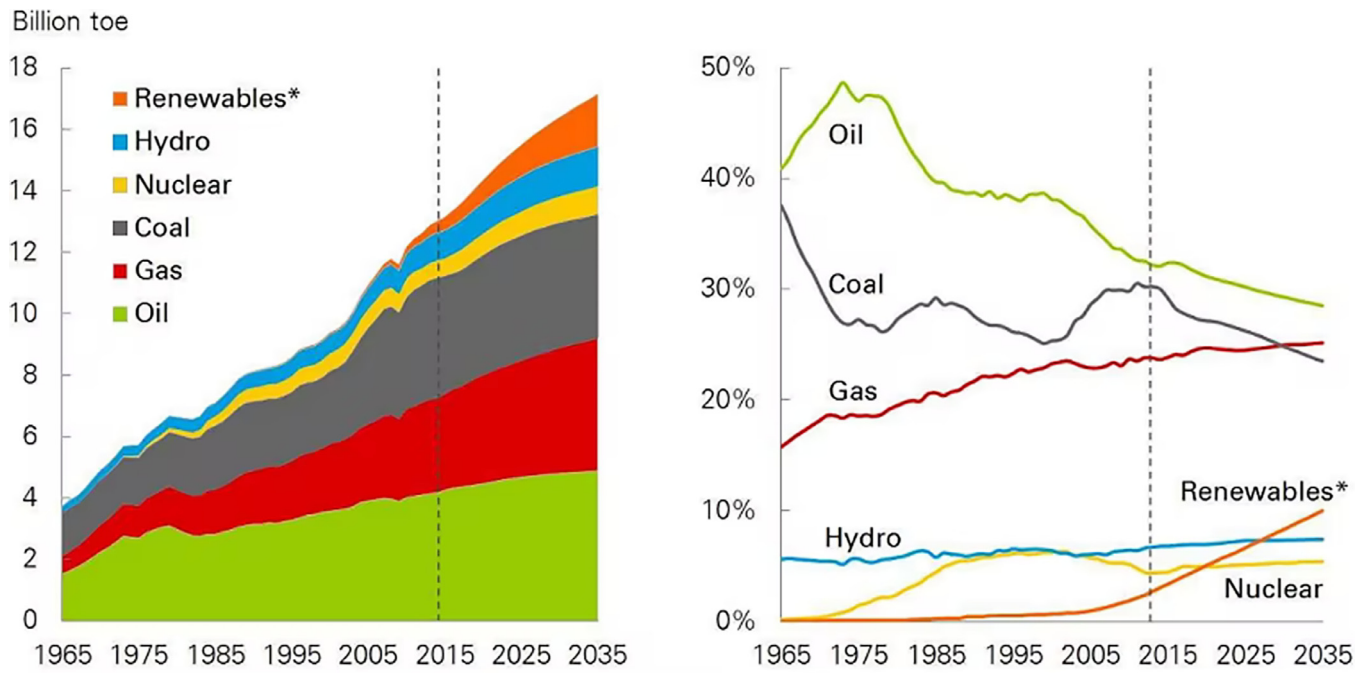

*Renewables includes wind, solar, geothermal, biomass, and biofuels

Fig. 2. Trends in worldwide primary energy consumption by fuel (on the left) and shares of primary energy (on the right) from 1965 to 2035 [11].

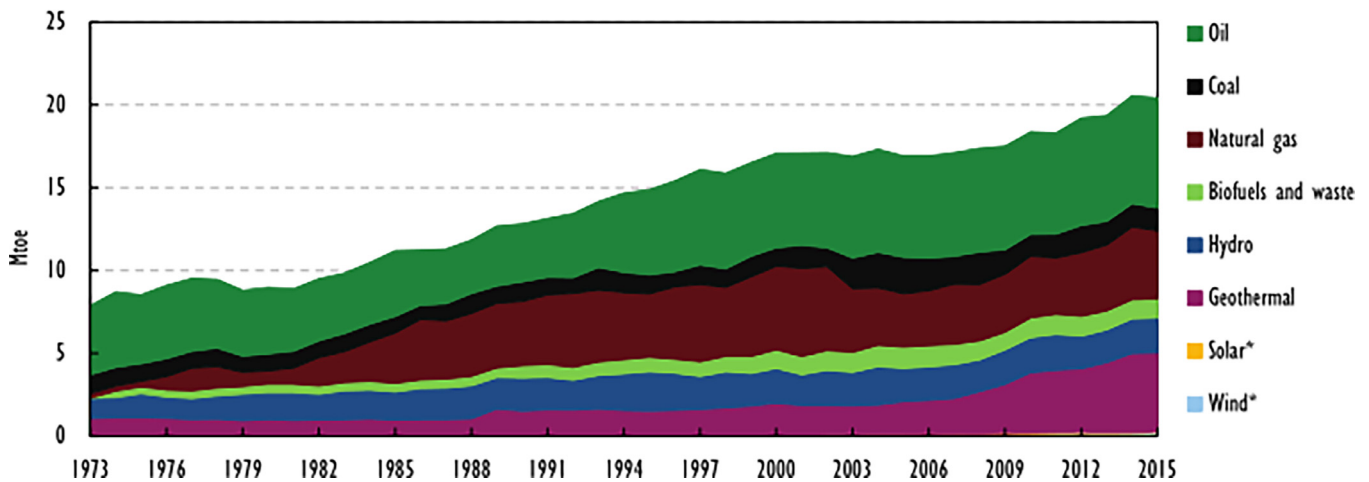

Fig. 3. Trends in New Zealand's TPES from 1973 to 2015 [13].

2.2. Energy statistics in New Zealand

New Zealand has a wide variety of energy sources, with a considerable share of renewable energy. New Zealand has the highest penetration of geothermal energy among the International Energy Agency (IEA) member countries and a significant contribution from hydropower, both of which are highly cost-competitive. In the absence of any direct subsidies or public support, the share of geothermal, hydropower, and wind power in the electricity and heat supply has been rising due to their favorable conditions. In 2014, New Zealand's renewable energy contribution to the total primary energy supply (TPES) was 40.6%, second only to Norway (44.4%) among all IEA member countries. This performance has already set a successful example among the IEA member countries [13].

Over the last 40 years, New Zealand's energy supply has been on an overall upward trend, except for a slow-down between 2000 and 2007, as shown in Fig. 3. As of 2015, New Zealand's TPES reached

20.4 million tonnes of oil equivalent (Mtoe), increasing 20.7% from 16.9 Mtoe compared to 2005. New Zealand's energy production structure has also changed significantly between 2005 and 2015, with the amount increasing from around 13 Mtoe to 16.4 Mtoe, respectively, as shown in Fig. 4. In 2005, the particular energy production and corresponding share, in descending order, was natural gas (25.1%), coal (24.6%), hydro (15.6%), geothermal (15.4%), biofuels and waste (1.0%), oil (8.4%), and wind together with solar (0.8%). In 2015, the particular energy production and corresponding share, in descending order, was geothermal (29.1%), natural gas (24.7%), oil (13.1%), hydro (12.8%), coal (11.8%), biofuels and waste (7.0%), wind (1.2%), and solar (0.3%). Significantly, geothermal has increased by 141.3% since 2005, which pushed up the share of renewable electricity production from 41.9% to 50.5% in 2015. As a whole, New Zealand achieved total energy self-sufficiency of 76% in 2005, compared to 81% in 2015 [13].

The use of renewable energy is vital to New Zealand's economy. The development of renewable energy can prevent New Zealand's economy

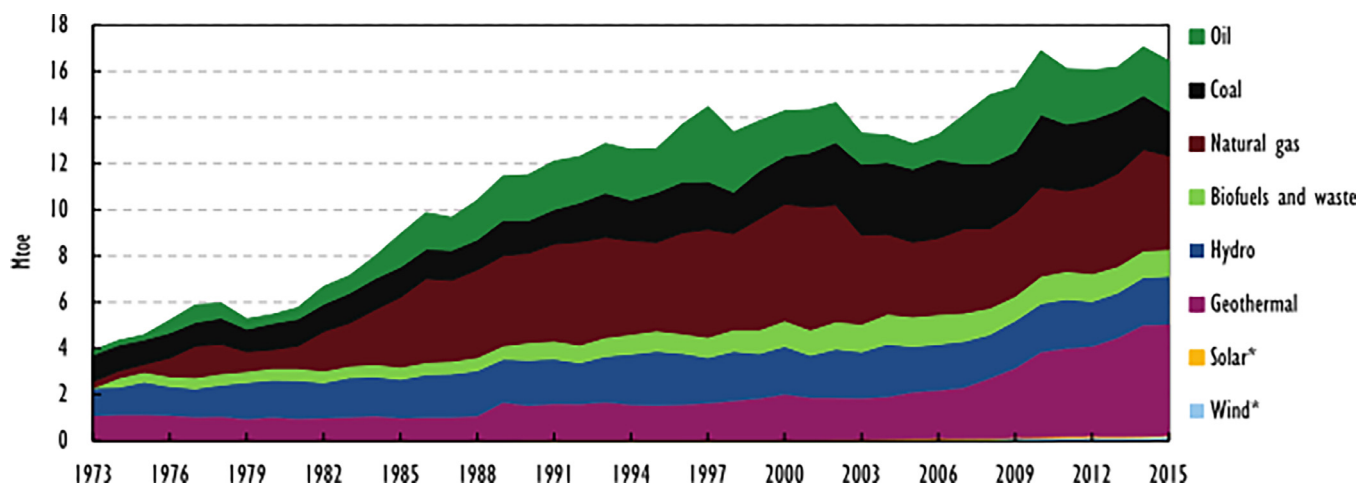

Fig. 4. Trends in New Zealand’s energy production by source from 1973 to 2015 [13].

from being limited by the price volatility and supply chain issues of fossil fuels. It can also help New Zealand to cope with climate change and meet future energy needs. At the same time, having abundant renewable energy creates a ‘clean’ and ‘green’ image for New Zealand in the world. This supports local tourism development and brings more world-oriented business opportunities to New Zealand [14].

2.3. Global wind energy development

Wind energy is one of the most commercially promising and dynamic renewable energy sources. Nowadays, more and more countries worldwide are successfully operating commercial wind turbines, promoting the rapid development of wind power. They cleanly generate electricity and do not emit polluting gases into the atmosphere [5]. According to the Global Wind Report 2021 published by the Global Wind Energy Council (GWEC), the total installed global capacity of onshore and offshore wind power has reached 743 gigawatts (GW) by the end of 2020, equivalent to a reduction in CO₂ emissions of 1.1 billion tonnes (approximately equal to the annual carbon emissions of Japan, the world’s fifth-largest emitter). While the wind energy market continues to grow, GWEC indicated that the present global growth rate will need to triple by 2030 to set the right course to achieve mid-century climate targets [15].

Wind turbines have now been deployed in over 90 countries, bringing the total global installed wind power capacity to approximately 650 GW by the end of 2019 [16]. Fig. 5 shows the world’s total installed wind power capacity from 1980 to 2019. It can be noted that the world’s total installed capacity was only 59,009 megawatts (MW) in 2005, and it increased to 197,026 MW, 436,828 MW, and 650,758 MW in 2010, 2015, and 2019, respectively. Meanwhile, the total installed capacity in 2019 is approximately 1.5 times that of 2015, and more than 11 times that of 2005, showing its rapid growth over the last decade [17]. The research [8] has predicted that wind energy (onshore and offshore) will be the largest source of electricity generation by 2050, supplying more than a third of the world’s total electricity demand, approaching 20,000 TWh/year.

At present, the EU, China, and the USA are the major wind energy players worldwide, generating far more electricity onshore and offshore than any other country or region in the world. The EU, China, and the USA have all taken different actions to develop wind energy, each of them at different rates and to different extents [18]. At the end of 2019, a significant share of the total global installed capacity was in Europe (22% onshore, 66% offshore), followed by China (37% onshore, 23% offshore), and the USA (17% onshore) [16]. By 2050, Asia (mainly China) is expected to dominate the wind power industry, with a predicted share of

Table 1

Some of the factors that have shaped the offshore wind industry development of the EU, China, and the USA over the past decades. Note: ‘+’ means over 50% dependence on fossil fuels (e.g., oil, coal, and natural gas), ‘-’ means less than 50%, and ‘+/-’ means partially. Reproduced from Ref. [18].

	EU	China	US
Dependence on fossil fuels at present	-	+	+
Historical concern	+	-	-
Installed investment	+	+	-
Planned investment	+	+	-
Streamlined licensing processes	+	-	-
Maritime spatial planning	+	+	+/-
Floating devices installed	+	-	-
Price and policy support	+	+/-	+/-

total global installed capacity of Asia (over 50% onshore, 60% offshore), followed by the EU (10% onshore, 22% offshore), and North America (mainly USA) (23% onshore, 16% offshore) [8]. Offshore wind farms are the focus of future wind energy development, and the EU, China, and the USA are all active in developing laws, strategies, and plans on offshore wind resources, building wind farms in the best locations from a perspective of wind source, while avoiding potential conflicts with other marine interests [18]. In addition, Table 1 summarizes some of the factors that have shaped the offshore wind industry development of these three major wind energy players over the past decades, which could also serve as a reference for other countries in developing wind energy.

In China, the government attaches great importance to enhancing the development and utilization of renewable energy, improving the ability to deliver clean electricity, and actively supporting the construction of wind power projects. All new projects must be included in the project planning of the Energy Administration and approved before they can be built. Local councils also provide project subsidies and value renewable resources [19]. The USA also attaches importance to the investment policy of renewable energy by encouraging people to develop wind energy through tax credit and establishing wind energy development funds, which leads to more occupations, increases people’s economic income, and greatly reduces polluting gas emissions [20]. Germany has also effectively promulgated preferential policies for renewable energy, with tariff-free policy for investors, public welfare funds, and financial subsidies to attract a large number of investors. Also, the Netherlands uses green energy exchange to encourage wind power generation [21]. McDowall et al. [22] indicated that the wind energy development and innovation system had experienced different stages, from the initial for-

Total Installed Capacity [MW]

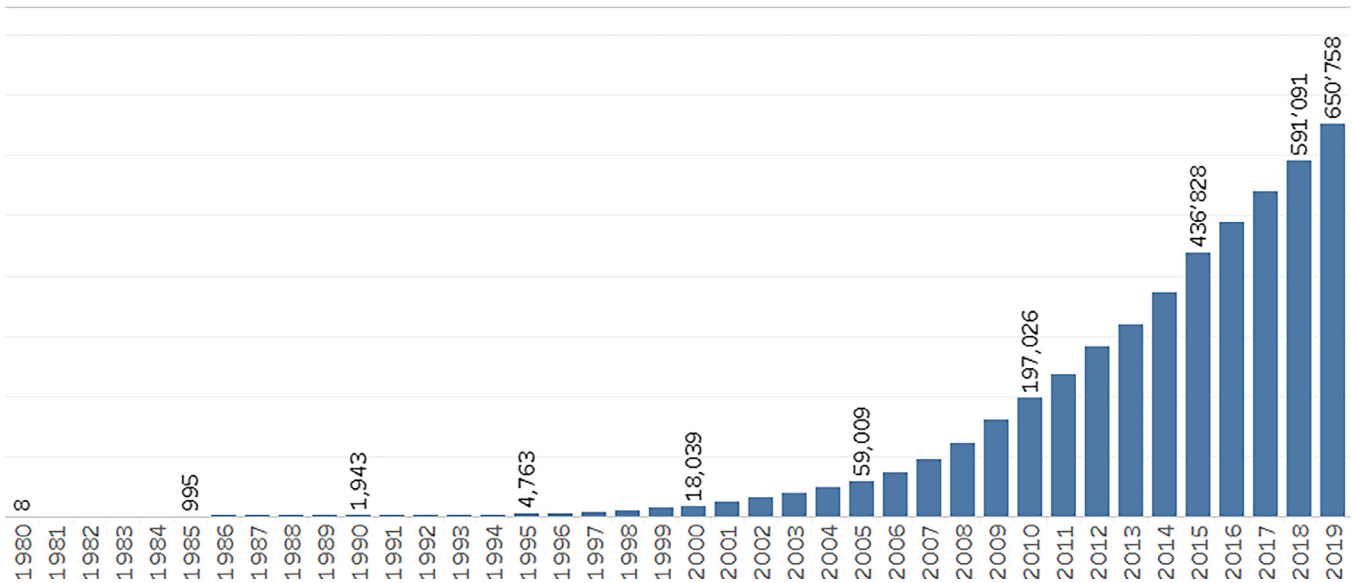

Fig. 5. The World's total installed wind energy capacity from 1980 to 2019 [17].

mative stages when the technology was first developed through to the current global commercial market. Policy instruments could effectively support deployment and guide further innovation efforts in later stages but are not necessarily successful in earlier stages. Thus, 'market pull' and 'technology push' policies were two important factors for the successful development of modern wind projects. However, the necessary structure of policy support and the institutional framework for addressing the challenges of emerging systems need to be adapted. This would require policy-makers to be engaged and adaptive throughout.

3. Wind energy development in New Zealand

Because of the considerable economic benefits, New Zealand's wind industry has grown rapidly compared to previous years [23]. According to a study [24] conducted by the Business and Economic Research Limited (BERL) in 2012, the wind industry in New Zealand contributed 649 full-time equivalents (FTEs) to national employment and contributed \$65 million to GDP between 2010 and 2011. In addition, the wind energy industry was predicted to achieve an installed capacity of 3,500 MW by 2030. In this situation, the wind industry would directly contribute 764 FTEs and add \$81 million to GDP. If employees' indirect benefits and household expenditures are also included, the total economic benefits would be 1,430 FTEs and \$156 million to GDP.

3.1. Wind energy resources

New Zealand is geographically located in one of the major atmospheric circulatory zones, an area of prevailing westerlies commonly referred to as the 'Roaring Forties'. Moreover, it is exposed to winds that cross the ocean and is largely free from other disturbances from land forms. Given these excellent natural conditions, the potential to generate electricity from wind energy in New Zealand is enormous [25]. Fig. 6 shows an outline of the wind resource distribution in New Zealand. Without considering other factors, economically feasible wind power generation generally requires wind speeds of at least 8 m/s. As can be seen from the figure, most areas with wind speeds in excess of 5 m/s are concentrated in the coastal areas and around the mountain ranges (e.g., hill-tops and ridgelines) of New Zealand. According to the findings reported in Ref. [26], coastal areas are generally more desirable for wind power development. However, thanks to advances in wind turbine tech-

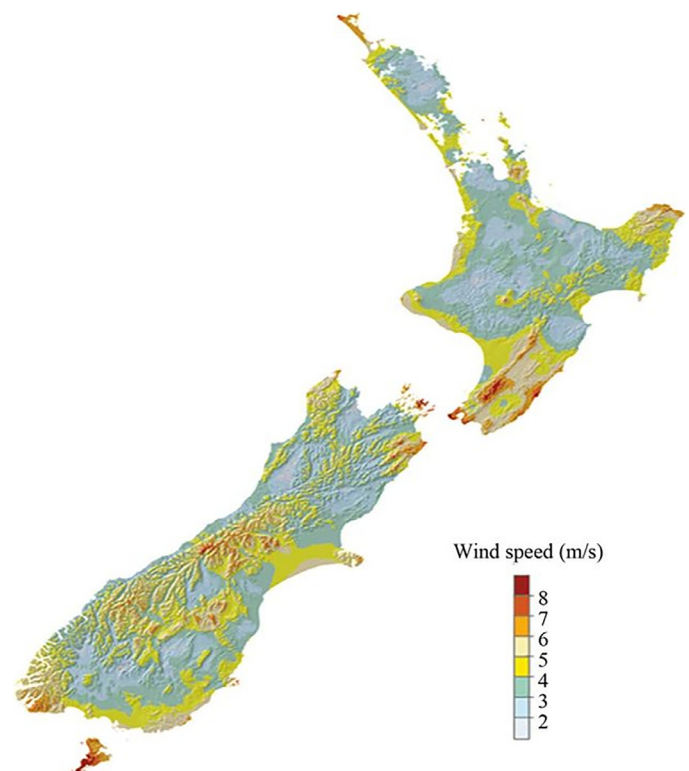

Fig. 6. Wind energy resources across New Zealand [27].

nology, it has also become economically feasible to operate in locations with lower average wind speeds [27].

In 2019, the combined capacity (also known as the 'rated output') of all the wind farms in New Zealand was 689 MW. This represents that 689 MW of electricity could be generated at any given moment if all wind farms were operating at full capacity. Wind turbines in New Zealand are operational around 90% of the time, however the quantity of power they generate is dependent on real-time wind conditions [28]. It has been measured that the average annual electricity production of

Table 2
Comparison of average wind turbine capacity factors. Reproduced from Ref. [7].

Country	Average capacity factor
New Zealand	41%
Australia	37%
United Kingdom	27%
United States	26%
Denmark	24%
Germany	17%
Global approx.	22%

New Zealand's wind farms is around 40% of their rated output, a parameter also known as the 'capacity factor'. The capacity factor is defined as the actual amount of electricity generated relative to the maximum power capacity, which is a measure of productivity [29]. Table 2 gives the comparison of average wind turbine capacity factors. It can be seen that New Zealand has one of the highest capacity factors in the world at approximately twice the global average.

3.2. Current development status

University researchers in New Zealand have been exploring wind resources since the 1970s, including learning about turbulence and other details. However, prior to 2004, the wind industry in New Zealand was slow to develop. The use of large wind turbines (capacity > 1 MW) in the construction of the 90 MW Te Apiti wind farm marked a step-change in the wind industry [23]. Currently, the smallest one is the Southbridge wind farm located in Canterbury, with a 0.1 MW turbine only. The largest one is the Tararua wind farm located in Manawatu, which has 134 turbines with a combined capacity of 161 MW [30]. At the time of writing there are 23 wind farms currently in operating and under construction within New Zealand, with a total capacity of approximately 1,045 MW. In addition, there are 10 wind farms that have already received consent, with a projected future capacity up to 2,077 MW [30]. This section describes the first few wind farm projects that were key to the establishment and development of the wind energy industry in New Zealand. Table 3 summarizes the basic information of the first few wind farm projects.

The Brooklyn wind turbine was New Zealand's first commercial-scale wind turbine. It was a Vestas V27 wind turbine with a capacity of 0.225 MW. The amount of electricity it generates over a year could provide the electricity needs of around 80 households over the same period. It was installed on the hills above Wellington and generated electricity in 1993. It ran reliably for 17 years before major repairs. In 1999, a wildlife sanctuary was built around the wind turbine. It was the first reserve in the world to be enclosed by a fence to prevent predators from invading [23]. In 2016, Meridian Energy replaced the old one with the Enercon E44 turbine (0.9 MW) that could generate sufficient electricity over a year to supply approximately 490 households over the same period [23,30,31].

The Hau Nui wind farm was New Zealand's first multi-turbine wind farm. In 1996 (stage 1), it originally had 7 Enercon E40 wind turbines with an individual capacity of 0.55 MW and a combined capacity of 3.85 MW. The wind farm was initially built by Wairarapa Electricity and subsequently operated by Genesis Energy [23]. The Hau Nui wind farm was located in the hills south of Martinborough, well suited to a wind farm. In 2004 (stage 2), Genesis Energy installed 8 additional latest Enercon E40 wind turbines. With a total capacity of 8.65 MW, the 15 wind turbines could provide sufficient electricity to the local grid to support the annual needs of approximately 4,200 households within the Martinborough area. Moreover, electricity could also be delivered as far north as Graytown, depending on demand and output [23,30,32]. Also, Genesis Energy is currently evaluating the possibility of further wind farm expansion [30,32].

The Tararua wind farm operated by Trust Power was New Zealand's first large wind farm. In 1999 (stage 1), it had 48 Vestas V47 wind turbines with an individual capacity of 0.66 MW and a combined capacity of 31.7 MW. The wind farm was located on the south side of the Manawatu Gorge within the Tararua Ranges, around 10 km from Palmerston North. The first expansion (stage 2) of the wind farm began in 2004, with the addition of 55 turbines, bringing the combined capacity to 67 MW [30]. After the resource consent was approved in 2004, the wind farm was expanded again in 2007 (stage 3). 31 new 3 MW Vestas V90 turbines, one of the world's most productive land-based wind turbines, were installed, increasing the wind farm's combined capacity to 161 MW. Tararua wind farm is the largest wind farm in New Zealand, with an average annual electricity production of 620,000 MWh [23,30,33].

The Te Apiti wind farm was the first wind farm in New Zealand using large-scale wind turbines, and it was also the first wind farm to provide electricity to the New Zealand national grid owned by Transpower, thus needed to operate in the electricity market. The wind farm was located on Saddle Road north of the Manawatu Gorge, around 10 km from Palmerston North. The wind resources around Manawatu Canyon are also excellent, with the landscape behaving like a wind funnel and creating high sustained wind speeds [23,30]. The Te Apiti wind farm started regular operations in 2004. The wind farm consisted of 55 Vestas V70 turbines, with an individual capacity of .65 MW could contribute to a combined capacity of 90 MW. The electricity generated could meet the annual demand for approximately 30,000 average households [34].

Fig. 7 presents the power curves for the wind turbines, as mentioned earlier. The power curve of a wind turbine characterises the relationship between power generation and wind speed at hub height. In addition, the power curve of Enercon E44 is used as an example to introduce some typical wind speeds. The cut-in speed, usually between 3 and 4 m/s, is the speed at which the turbine initially begins to rotate and generate power. Nevertheless, typically somewhere between 12 and 17 m/s, the power output reaches the generator's limitation, which means the rated output wind speed has been reached. The turbine is designed to restrict the power output at this maximum level at higher wind speeds, and the power output does not climb anymore. The forces on the turbine framework keep going up when the speed exceeds the rated output wind speed, so there is a threat of damaging the rotor at some point. As a result, the rotor is brought to a halt by a braking mechanism. This is known as the cut-off speed, which is usually approximately 25 m/s [35].

In spite of the uncertainty and delays resulting from the Covid-19 pandemic, several wind farm projects have been completed or are under construction in New Zealand. One example is the Waipipi wind farm near Waverley, South of Taranaki. It was fully commissioned in March 2021, with an installed capacity of 133 MW and an average annual power output of 455 GWh [37]. The Mt Cass wind farm in North Canterbury has been financially closed in 2021 and will start construction shortly. The installed capacity is expected to be up to 93 MW [38]. Construction of the Turitea wind farm in the Tararua Ranges is continuing, but has been affected by delays. Its installed capacity is 222 MW, which is the onshore wind farm with the highest combined capacity in New Zealand at present [39,40].

3.3. Policies and institutional settings

Wind farm development in New Zealand is unusual. There is no government subsidy and tariff support mechanism to date. Although the government provided wind energy with the Projects to Reduce Emission (PRE) program from 2003 to 2004, and some earlier wind projects have received government support through PRE, most wind farms in New Zealand are still commercially sensitive [41]. As the New Zealand government's electricity regulations restrict some independent developers from entering the national market, only a few power companies in New Zealand are developing wind farms. Compared with many other countries, the New Zealand government lacks policy support for investors to

Table 3
Basic information of the first few wind farm projects. Reproduced from Ref. [30].

Wind farm	Year installed	Operator	No. of turbines	Turbine capacity (MW)	Installed capacity (MW)	Blade length (m)	Tower height (m)
Brooklyn	1993 (replaced in 2016)	Meridian Energy	1	0.9	0.9	20.8	44
Han Nui	1996 (stage 1)	Genesis	7	0.55	3.85	20	46
	2004 (stage 2)	Energy	8	0.6	4.8		
Tararua	1999 (stage 1)	Trust	48	0.66	31.7	23.5	5
	2004 (stage 2)	Power	55		36.3		
	2007 (stage 3)		31	3	93	45	65
Te Apiti	2004	Meridian Energy	55	1.65	90	35	70

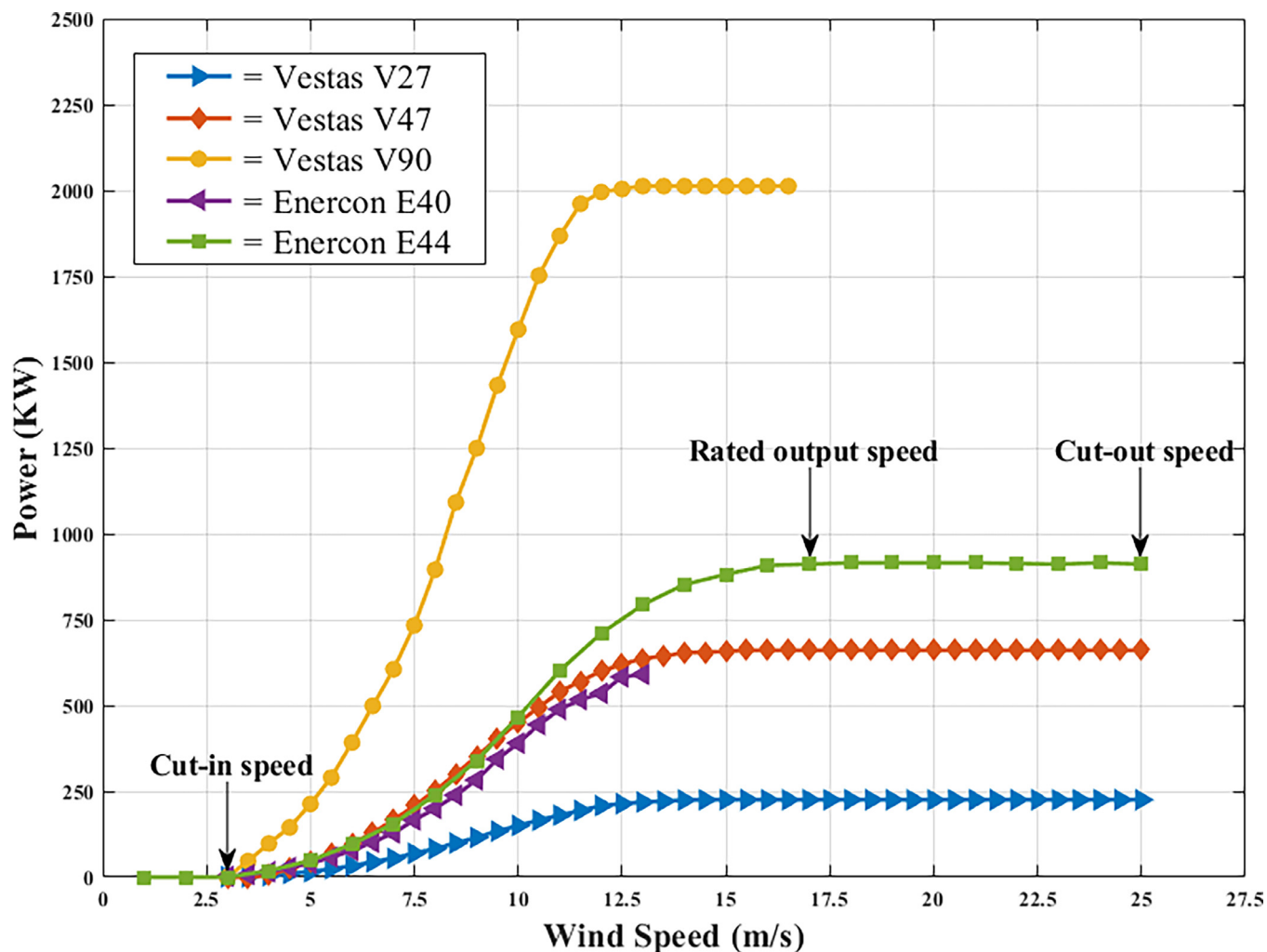

Fig. 7. Comparison of the power curves of the wind turbines mentioned above. Reproduced from Ref. [36].

enter the wind power industry [42]. Wind energy investment was very low in 2012, but after 2012, wind energy investment started to increase gradually. Fig. 8 shows the total wind power capacity installed in New Zealand year by year. In 2003, the total amount of installed generation was less than 100 MW, but in 2014 it reached 1,000 MW. After 2014, the new amount of power generation is maintained at approximately 100 MW per year, playing an important role in the development of wind energy resources in New Zealand. It is expected that the total installed capacity will reach 3,500 MW by 2030. If New Zealand’s wind energy is combined with electricity generated by other forms of energy, it can form a key part of New Zealand’s electricity system. It is expected to generate at least 20% of total electricity in 2030 [43].

New Zealand’s Emission Trading Scheme (NZ ETS) was applied to the electricity sector in 2010, which remains the main driver of investment

in renewable energy projects in New Zealand at present. To motivate investment in renewable energy, the NZ ETS requires carbon emitters to acquire and surrender emission units to match their associated operational activities. Through government industry allocations, sequestration, quarterly auctions, secondary markets, or government, emitters can purchase units at a fixed price [44]. However, there are currently no sector-specific or fiscal mechanisms (e.g., feed-in tariffs or renewable portfolio standards) that support or constrain the renewable energy sector in New Zealand [40]. Research [42] has shown that countries with successful wind energy industries usually exhibit one or more of the following characteristics:

- From small- to large-scale wind power, the development involves a broad range of advancements.
- From individuals to large corporations, the investors are diverse.

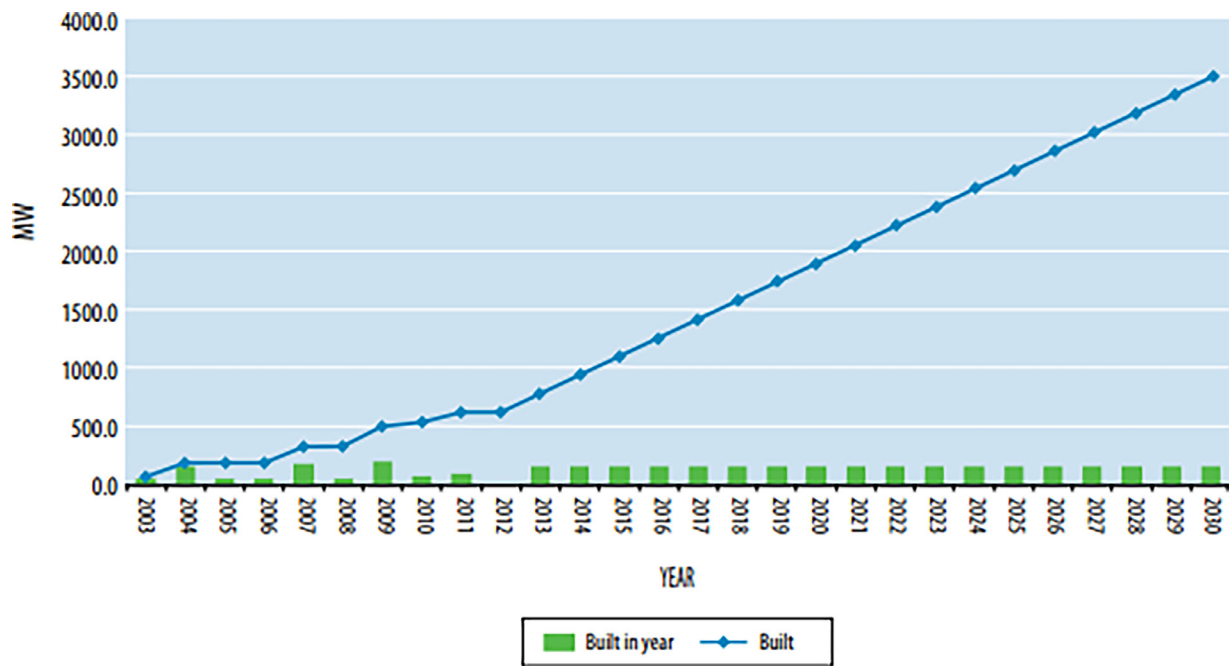

Fig. 8. Built wind generation with projection to 2030 [43].

- Have reliable payment mechanisms and a stable generation market.
- Wind energy targets are clear or legally binding.
- Turbines and wind farms are widely distributed.
- Wind farms have gained public acceptability and support.
- A fair and competitive environment for wind power development.

These factors are unlikely to be achieved through the market alone. Furthermore, there has been little government intervention, which has limited the potential development of wind energy in New Zealand [42].

4. Challenges to the development in New Zealand

The development of the industry needs to be dominated by the market. Despite having one of the best wind energy resources in the world, New Zealand's wind energy industry is still growing slower than the average of other OECD countries. This may be due to the lack of proper government policy support [45]. There is still a long way to go in developing wind energy because wind farms (significantly larger farms with large-scale wind turbines) in New Zealand have encountered strong resistance to their advancement. In addition to insufficient government policy support, the main barriers to developing wind energy in New Zealand are cultural, environmental, economic, and social influences.

4.1. Cultural significance

New Zealand's Resource Management Act (RMA) 1991 states the necessity to respect the historical and cultural significance of Māori, which primarily includes the intrinsic links between Māori and with the natural environment and specific cultural values (e.g., ancestral lands, lakes, ruins, sacred sites, etc.) [46]. Large-scale wind turbines are a modern artifact and may interfere with the character and overall fabric of areas of historical and cultural significance [25]. In 2007, Unison Networks Ltd proposed to build a 37-turbine wind farm in Eastern Hawkes Bay that has been blocked by 86 Māori. They argued that the wind farm to be built on the ridge would harm Māori interests, destroy the natural landscape, adversely affect their cultural links, and be inconsistent with sustainable development. The court eventually rejected the wind farm construction, giving the reason that the adverse effects on the landscape were considered to be outweighed the benefits of wind power in terms of

reducing greenhouse gas emissions [47]. In a similar situation in 2009, Meridian Energy wanted to construct 176 wind turbines on the Lammermoor Range in Central Otago, but the Maori also rejected it on the basis of the impact on their ancestral culture and the damage it would cause to the local environment [48]. Because the wind farm could change the original relationship between the site and the surrounding environment and/or affect the visual catchment, it strikes at a core cultural interest of Māori, so they must be involved in the decision about the construction associated with the wind farm [25].

4.2. Environmental impacts

Regardless of the type of power generation, its impact on the environment is inevitable, including wind farms [25]. The environmental impacts are diverse, and three of the most significant issues regarding wind farms are highlighted here [23]: noise impacts, ecological effects (birds are a key issue), and visual amenity.

4.2.1. Noise impacts

One of the most common concerns people have about wind farms is noise, especially for people living near wind farms. Wind farms typically have two sources of noise, the mechanical operation of the turbine (triggered by the interaction of turbine components, such as gearboxes and generators) and the aerodynamic sound (triggered by the vibration of the air flowing over the turbine blades). Moreover, the design and operation of the turbines, the spacing between turbines and residences, topography and land cover, present background noise levels, and human sensitivity to the noise are important factors that influence the actual noise level of a wind farm [25]. Noise issues were reported at Hau Nui, New Zealand's first multi-turbine wind farm. Although corrective measures were taken to suppress the tonal noise, the public felt that this did not compensate for the actual damage that the noise had created. In response, the Energy Efficiency and Conservation Authority (EECA) has promoted and funded the development of a domestic standard for assessing and managing wind farm noise [23]. Although noise standards are being used in many consents, their limitations are becoming increasingly evident, especially with regard to monitoring regimes. Councils set increasingly complicated monitoring conditions for each approved wind farm consent, leading to increased noise standards. As

a result, the standards committee on wind farm noise reconvened and revised the domestic standards in the late 2000s, and the revised standard was released to the public in 2010 [49]. The report [23] provides the following recommendations for how New Zealand should deal with wind farm noise impacts in the future:

- Combine optimal international practice with local conditions to build a robust noise management framework.
- Ensure that the noise management framework is established with the involvement of local experts to ensure its successful application further.
- Encourage developers to implement reasonable procedures for managing noise complaints and resolving noise problems.

4.2.2. Ecological effects on birds

Due to its unique geographic location, New Zealand is known worldwide for its global biodiversity, especially its native birds. In recent times, many of New Zealand's bird species have become extinct or are threatened with extinction due to the introduction of predators (e.g., cats and rats). As a result, there is public concern about the impact of wind turbines on native birds, especially in light of reports of bird deaths caused by wind turbines in other countries and regions [50]. Since the early wind farms in New Zealand were built in areas without large numbers of native birds, the impact on birds was minimal. Furthermore, many wind farms have included bird impacts in recent years in their approval process. Where significant bird impacts have been identified at an early stage of the survey, developers have decided not to proceed with development on some sites to avoid ongoing public concerns about bird impacts in the future [51]. The report [23] provides the following recommendations for how New Zealand should deal with wind farm ecological effects on birds in the future:

- Consider whether birds pose a potentially significant problem at an early stage of wind farm development.
- Identify patterns of bird activity to address such potentially significant problems.
- Select suitable sites to avoid placing turbines in bird corridors. It helps to reduce the need to address ongoing public awareness of bird impacts.
- Choose to abandon a potential project due to a severe bird problem.
- Incorporate the design of bird monitoring programs and statistical procedures as part of the wind farm project design.
- Ensure that monitoring is conducted to appropriate standards and examine the results of the monitoring program.

4.2.3. Visual amenities

The wind farm is a large technology that can significantly impact the New Zealand landscape, and some wind farms have faced longstanding opposition in terms of landscape. While planning law has been largely silent on wind projects, most communities still cannot accept wind farms in their landscapes [23]. In New Zealand, the highest and most consistent wind speeds are generally located in large open areas or coastal environments. However, these sites have great natural beauty and are close to both urban residential areas and rural areas in many cases. Therefore, there are many land scenery factors to consider before establishing a wind farm. For example, in the early 1990s, at the entrance to the Port of Wellington, the local line company proposed to build wind turbines for Baring Head. Wellington Port is a famous tourist attraction. The proponents initially ignored the scenery here, but the local residents were worried that wind turbines would obscure the beautiful scenery, so the local residents began to organize their opposition to establishing the wind farm. Finally, the application for wind farm construction at this location was rejected [52]. In addition, roads, buildings, transmission lines, and other physical infrastructure should be considered. All project proposals are regulated through the consent provisions of the RMA. Moreover, the government implemented a series of amendments

to improve the RMA in 2009 [53]. The report [23] provides the following recommendations for how New Zealand should deal with wind farm visual amenities in the future:

- Develop clear guidelines for assessing wind sites and the surrounding landscape.
- Collaborate between the wind industry and the landscape community to ensure that the landscape community is fully informed and involved in assessing wind farm proposals.
- Use visual simulations to experience and understand landscape impacts.
- Adopt an effective decision-making process to make the final judgment on landscape issues - after all, it is impossible to make large-scale wind turbines 'invisible'.

4.3. Economic issues

The economic situation of New Zealand wind energy has changed dramatically in the past few years. In 2003-2004, the government eliminated small subsidies and eliminated unnecessary incentive measures [25]. Economic issues are usually related to investment costs and competitive trends in the investment process [54], this section provides a brief discussion of the following.

4.3.1. Investment costs

The initial cost of wind farms is relatively high while operating costs are relatively low. There is a lengthy application process to get a new wind farm approved. One project reportedly went through a two-year approval process and cost an additional NZ\$120 million [42]. In the current New Zealand market, independent wind energy developers can sell electricity to the wholesale or enter into power purchase agreements with electricity retailers. Since the government does not stipulate a power purchase agreement, electricity retailers can purchase or not [55]. The New Zealand wind power investor base has only three major developers. The New Zealand electricity sector is characterized by a high degree of concentration, with five companies owning 91% of the generation capacity and supplying up to 97% of the total demand. However, the electricity market is highly volatile and the return on investment is risky [56], creating a barrier to the development of wind energy. This market structure makes it more difficult for some small investors to obtain power purchase agreements. Small developers need a stable and predictable income stream to obtain financing, making it difficult to invest in wind energy projects [57].

4.3.2. Competitive trends

Wind power will compete with other forms of renewable and non-renewable energy, with the greatest competition coming from hydroelectric power [4]. New Zealand has large-scale hydroelectric power generation facilities, which currently already account for over 56% of total electricity generation [3]. This is due to the abundance of mountains, rivers, and lakes in New Zealand. However, the ecological impact of hydroelectricity projects (e.g., the flow of rivers, biology, and vegetation on the banks) can be reduced if they are appropriately operated and managed. Although there are many hydroelectric power stations in New Zealand, this does not mean that hydroelectric power stations have reached a bottleneck. The Parson Brinkerhoff Associates meeting noted that there is still more than 1,851 MW capacity of hydropower that can be used in the future [58]. Hydroelectric power stations produce very little greenhouse gas during operation, and hydroelectric technology is well established in New Zealand. Therefore, it has a huge competitive advantage over wind power generation.

4.4. Social influences

Each region in New Zealand has different requirements for connection to the wind power network [59]. New Zealand's main high-voltage

Table 4
Classification of general HAWT related to the rotor diameters and power ratings. Adopted from Ref. [67].

		Rotor diameter (m)		Swept area (m ²)		Standard power rating (kW)	
		From	To	From	To	From	To
Small-scale	Micro	0.5	1.25	0.2	1.2	0.004	0.25
	Mini	1.25	3	1.2	7.1	0.25	1.4
	Household	3	10	7	79	1.4	16
Small commercial		10	20	79	314	25	100
Medium commercial		20	50	314	1963	100	1,000
Large commercial		50	100	1,963	7,854	1,000	3,000

transmission grid has been used for a long time, and it shows signs of stress, which results in short service life. Because it is close to the limit of existing capabilities, it is necessary to upgrade the wind power generation device further and the grid [60]. However, in New Zealand, a lot of evidence is needed to show that new power generation equipment must be installed to run electricity at this stage. Otherwise, it is unlikely to build a new power transmission capacity [25,23].

Before 2008, the government approved the Project Emission Reduction (PER) program, which allowed participants to achieve international trade by bidding for government-provided projects [41]. In 2009, the government introduced the amendments to the RMA, and one of the main goals of the revised bill is to establish an Environmental Protection Agency (EPA) [60]. In New Zealand, most small wind energy projects can be approved by the EPA within a few months. Local residents always oppose large-scale wind farms, so it is challenging to get approval. The New Zealand government has proposed adjustments to regulations to address some of the barriers to wind power generation in order to encourage and promote small-scale wind turbine projects [61].

5. Development of small-scale wind turbines in New Zealand

As mentioned earlier, wind farms (significantly larger farms with large-scale wind turbines) in New Zealand have faced longstanding opposition [25]. Support for small wind power projects tends to be more positive than for larger ones. The most likely explanation for this is that small wind power projects are less noisy and less visually obtrusive to the landscape. Moreover, Refs. [62,63] indicate that the noise impacts and visual amenities seem to be the most common factors in local public opposition to wind projects. An increasing number of countries worldwide are actively seeking to use renewable energy for micro-generation, which has the potential to provide carbon-neutral electricity [64]. In New Zealand, although few people currently use small wind turbines for micro-generation, small-scale wind turbines would face little social resistance and lower costs would be more easily funded, thus expanding the investor base in New Zealand. Smaller wind turbines would be installed in a more decentralized manner to increase the safety of the system and reduce transmission and distribution losses [65]. In New Zealand, small-scale wind turbines have the theoretical potential to make a significant contribution to achieving renewable energy goals if they are established in residential areas [42]. However, several factors are constraining the development of small-scale wind turbines. Firstly, the lack of a consistent and transparent planning process by New Zealand's consent authorities has failed to engage more potential investors. Next, there is a shortage of sufficient qualitative information on small-scale or micro-wind projects in New Zealand. In addition, the lack of comprehensive legislation in New Zealand and the nonexistence of guaranteed electricity buy-back rates (feed-in tariffs) are hindering the market growth [66].

5.1. Classification of small-scale wind turbines

Typically, wind turbines can be classified according to their rotor diameters and standard power ratings. Ref. [67] gives the detailed classification results, as shown in Table 4. It can be seen that small-scale wind

turbines usually have a rotor diameter ranging from 0.5 m to 10 m, and a standard power rating from 0.004 kW to 16 kW. In contrast to the medium and large ones, small-scale wind turbines produce more expensive electricity, especially in areas with the poor wind. However, small-scale wind turbines will become a reliable source of energy when they are appropriately sized and used under their optimal conditions, such as in the urban environment [8]. Small-scale wind turbines can be considered a source of socio-economically valuable energy in most developing countries. Small-scale wind turbines can also serve as a good power source in areas far away from the grid power in developed countries. However, further development of small-scale wind turbines requires reasonable cost control. Cost includes two major factors: 1) the initial cost per Watt of power, and 2) the unit cost per kWh it produces [68]. That is, small-scale wind turbine power generation has real value when both factors are at an affordable rate.

5.2. Urban environment considerations

The capacity factor of a wind turbine is determined by its average power output divided by its maximum power capacity, usually higher is better [29]. Poletti and Staffell [69] found that the average capacity coefficient over all current and potential sites with large wind turbines is about 40% in New Zealand, with the highest of 45% in spring and the lowest of 35% in autumn. Wind speed in urban areas depends on local parameters, while wind speed on roof-tops depends on the location and shape of the roof, as well as the shape and size of the surrounding buildings [70]. According to previous research [71], the average capacity factor of roof-top turbines in Europe, the UK, and the USA was changing from 4% to 6.4%. But the capacity factor would increase to 10.4% when the turbine is installed in a relatively open place (e.g., 10 m away from buildings and trees). Roof-top wind turbines, the most common in urban environments, are made up of a turbine, a power inverter, and appropriate electronics to match the frequency of the grid supply. A number of units can be connected by simply plugging into a normal household outlet [64]. The Wind Energy Integration in the Urban Environment (WINEUR) project was supported by Intelligent Energy Europe began in 2005. The major objectives of this project can be summarized as 1) determining what is needed to integrate small-scale wind turbines into the urban environment, 2) promoting the emergence of this wind energy technology, 3) raising awareness among municipalities and decision-makers, and 4) assessing and improving the prospects for social, aesthetic, architectural and urban planning acceptability of wind energy technology [72]. In addition, WINEUR project recommends that [71]:

- The average wind speed at the location where the wind turbine is installed should be 5.5 m/s or even higher.
- The roof of the building where the wind turbine is installed should be around 50% higher than the surrounding objects.
- The wind turbine should be installed towards the centre of the roof in the most common direction of the wind, having the rotor's lowest position being a minimum of 30% of the building height well above the roof level.



Fig. 9. Swift turbine installed on the roof of a small residential house [76].

According to the New Zealand wind atlas [73], the mean wind speed at 10 m (approximately equivalent to the height of a three-storey building) above ground level is around 4.5–5.0 m/s in Auckland, 6.5–7.0 m/s in Wellington, 5.5–6.0 m/s in Dunedin, 7.5–8.0 m/s in Canterbury, and up to 9 m/s around the rural South Island. Therefore, based on the recommendations of the WINEUR project, it is more appropriate to promote small-scale wind turbines in the urban environment of the South Island of New Zealand. Most New Zealand houses are mainly built with light timber with a standard-alone single-storey structure. Therefore, noise effect and structural stability seem to be challenging for installing roof-top wind turbines in such houses [71]. The National Standard for Wind Turbine Sound Assessment and Measurement states that the sound level at the boundary of any residential site should never exceed 40 dB or background noise plus 5 dB [49,71]. The Swift turbine (see Fig. 9) developed by Renewable Devices Swift Turbines Ltd was selected and tested by New Zealand trials, claiming a noise level of less than 35 dB was achieved; it may be acceptable [71]. Wind trials at the University of Warwick encountered noise complaints from some building-mounted turbines, while one turbine eventually had to be removed owing to structural damage to the eave wall on which it was installed [74]. Through the results of the research in Ref. [71], it was found that a Swift turbine with a rated output power of 1.5 kW and a rotor diameter of 2 m would generate 526–841 kWh/annum in urban houses when based on a capacity factor of 4–6.4% and a mean wind speed of 5.5–6.3 m/s. If the average electricity consumption of a New Zealand house is analyzed at 8000 kWh/annum [75], approximately 13%–21% of the annual electricity demand can be addressed by installing Swift roof-top turbines. To avoid the adverse effects of turbulence, New Zealand guidelines limit the spacing between turbines to at least five times the rotor diameter, which means a maximum of two such turbines per house at the same for most cases [71]. With this assumption, the electricity generation potential of New Zealand houses using roof-top wind turbines will remain

between 1,052 kWh/annum and 1,682 kWh/annum. Fig. 9. shows two Swift turbines installed symmetrically on the roof of a residential house.

5.3. Small-scale distributed generation

Given the many challenges to the development of large-scale wind power in New Zealand, another way to effectively harness wind energy is to develop small-scale distributed generation (DG), also known as the ‘micro-generation’ [64]. Micro-generation usually refers to a suitable sized power technology to provide partial or full power to a household or small business. Micro-generation technologies are a subset of DG and are primarily designed to serve local rather than export to the national electricity grid [77]. The Parliamentary Commissioner for the Environment (PCE) has commissioned an assessment of the potential for micro-generation energy services in New Zealand. The Commissioner [25] found that advances in micro-generation technologies, as well as advances in metering and monitoring systems, could help to enhance New Zealand’s future electricity supply. The Commissioner believed that micro-generation systems could provide a strong guarantee of environmental sustainability in New Zealand. In the Electricity Industry Participation Code 2010 (Code), there are rights and responsibilities for owners of small-scale DG in relation to accessing the distribution network and selling electricity. Some other requirements can be found in the Electricity (Safety) Regulations 2010, the RMA 1991, local government policies and codes, and distributor policies and codes .

The wind energy conversion system (WECS) is one of the cores of wind power technology, and it consists of three main aspects: aerodynamic, mechanical, and electrical [78], which can be seen from Fig. 10. Wind turbines use aerodynamically designed rotors to harvest energy from the wind and convert it into mechanical energy (mainly rotation). Modern wind turbines typically have three blades. Since the blade tip speed should be less than half the speed of sound, the rotational

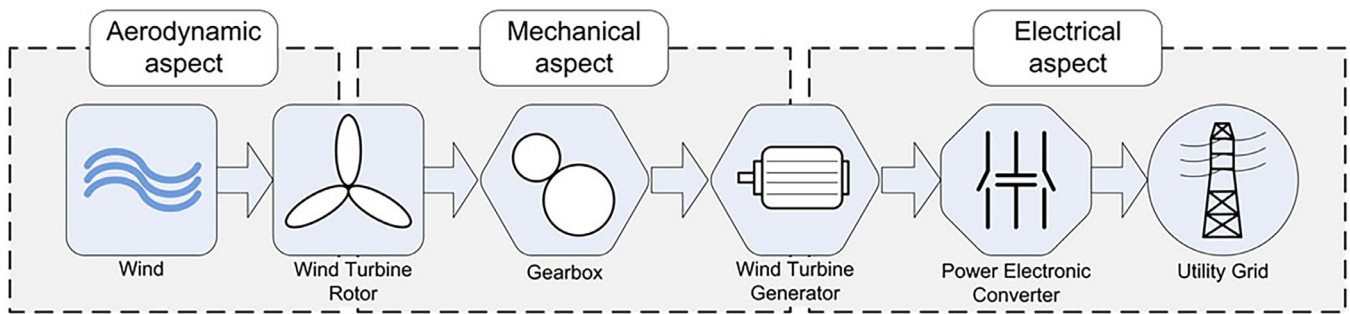

Fig. 10. Basic energy conversion stages in modern wind turbines [78].

Table 5

Approximate small-scale wind turbine output (10%-30% capacity factor). Adopted from Ref. [64].

Rated output (kW)	Hours in a year	Amount generated in one year at rated wind speed	Amount generated in one year (10%-30% capacity factor)		Amount generated in one day (10%-30% capacity factor)	
			From	To	From	To
0.5	8,760	4,380 kWh	438 kWh	1,314 kWh	1.2 kWh	3.6 kWh
1	8,760	8,760 kWh	876 kWh	2,628 kWh	2.4 kWh	7.2 kWh
3	8,760	26,280 kWh	2,628 kWh	7,884 kWh	7.2 kWh	21.6 kWh

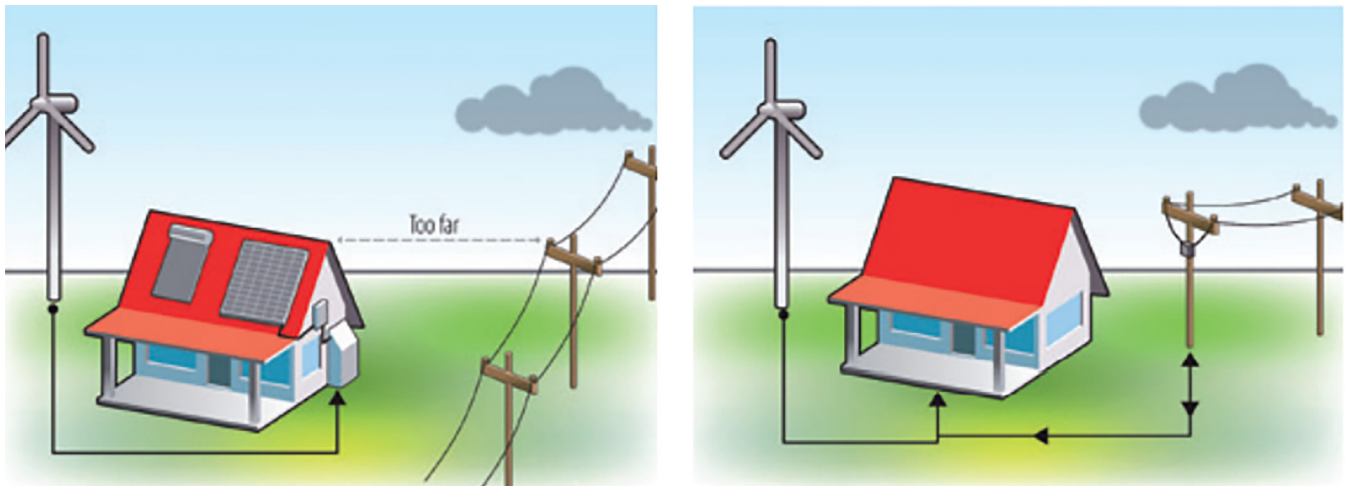

Fig. 11. Diagram of SAPS system (on the left) and grid-connected system (on the right) [64].

speed will decrease as the blade radius increases. The gearbox is used to adapt to the rotor to generator speed, and the generator is used to absorb mechanical power and then convert it to electrical power. It is usually the simplest and most efficient way to convert low-speed, high-torque power into electrical energy. Finally, the generated electrical energy is transmitted through the converter and then fed into the grid [79].

Small-scale wind turbines can operate as either grid-connected or off-grid systems (also known as the ‘stand-alone power systems’, abbreviated as SAPS) [64], as shown in Fig. 11. Grid-connected systems are connected to the local power network, using an inverter that converts direct current (DC) electricity into grid-compatible alternating current (AC) electricity and a special meter that measures imported and exported separately [80]. In the event of excess wind, lead-acid battery packs are often used to store surplus generated electricity for use in conditions where the wind is insufficient or the turbine is not operating correctly [81]. There is also the option of exporting part of the electricity to the grid and selling it to electricity retailers when surplus power is generated. In off-grid situations, small-scale wind turbines require a SAPS, and use battery banks or other effective energy storage methods to store the generated power [82]. The method of energy storage is cru-

cial. In the case of the battery bank, the choice of size and design directly determines the performance and lifetime of the SAPS. If the battery bank is too small, it may often discharge at low levels; if it is too large, it may not be fully charged regularly, both of which will shorten the life of the SAPS [64].

In contrast to the ideal situation, the reality is that wind turbines will not always operate at ‘rated wind speed’. Instead, a small-scale wind turbine will only generate an average of 10% to 30% of its rated power output over a year [83]. Ref. [53] gives some data for operating small-scale wind turbines in New Zealand based on reasonable assumptions, as shown in Table 5.

5.4. Case study for improving the efficiency of a small-scale roof-top turbine

Because of the relatively complex structure and congested environment, the appropriate type of wind turbine must be considered if urban wind energy is to be developed and utilized. Table 6 compares Vertical Axis Wind Turbines (VAWTs) and Horizontal Axis Wind Turbines (HAWTs). VAWT has many promising features. Considering the barriers

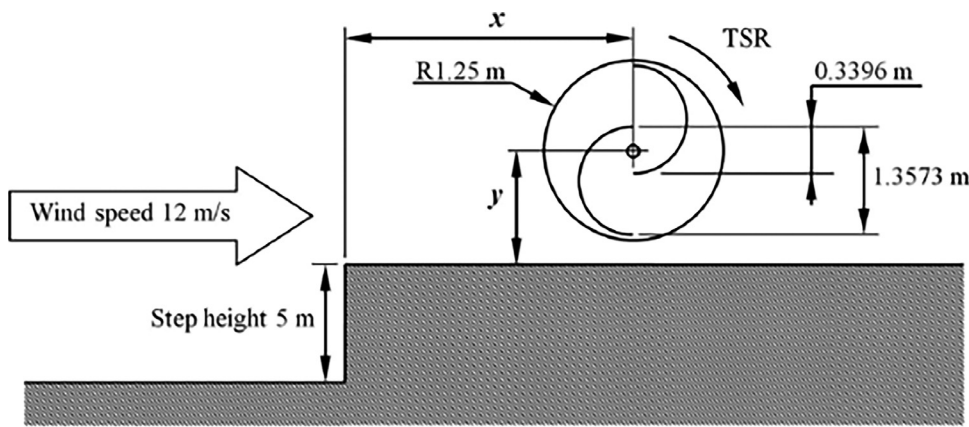

Fig. 12. Diagram of the installation of the studied Savonius turbine [89].

Table 6
Advantages of VAWTs compared to HAWTs. Adopted from Ref. [84].

	VAWT	HAWT
Tower sway	Small	Large
Yaw mechanism	No	Yes
Self starting	No	Yes
Overall formation	Simple	Complex
Generator location	On ground	Not on ground
Height from ground	Small	Large
Blade's operation space	Small	Large
Noise produced	Less	Relatively high
Wind direction	Independent	Dependent
Obstruction for birds	Less	High
Ideal efficiency	More than 70%	50-60%

to developing the wind industry in New Zealand mentioned in Section 4, choosing VAWT seems to be a better choice.

Among the various VAWTs, the Savonius wind turbine not only has all the advantages (except 'ideal efficiency' is low) in the table above but also has the high startup and full operation moment [85]. It is well worth promoting in the wind energy industry in New Zealand. In addition, many studies [86–88] have proposed the use of unique urban structures to increase wind speed and thus the efficiency of wind turbines. This section presents a typical case study that considers the Savonius wind turbine installed above the bluff body and on the flat surface. This study was initially proposed in work by Goh and Schlüter [89], and for completeness, the numerical studies are summarized below.

5.4.1. Numerical methodology

Due to the increasing interest in urban wind energy, installing wind turbines on the roof of cuboidal buildings became one of the possible scenarios. In order to understand the dynamic behavior of the turbine in such situations, Goh et al. [90] conducted the tow testing of a test rig equipped with a three-bladed Savonius mounted above a bluff body. The experimental results from that work were used to validate some of the simulation setups used for the present case study. Computational fluid dynamic (CFD) simulation was performed in this case study by running the commercial software ANSYS CFX inside the Workbench environment. ANSYS CFX is based on a finite volume method (FVM), and it discretizes the domain of interest via cell-vertex finite control volumes. The flow variables and properties are computed at the vertices of the mesh elements in vertex-based schemes. During the study, the air (wind) was assumed to have constant properties at 25 °C. The rotating sub-domain function of the CFX and transient simulations were applied, and the Shear Stress Transport (SST) turbulence model that most closely approximated the experimental results was ultimately adopted.

5.4.2. Studied installation scenarios and parameters

The Savonius wind turbine is simpler and cheaper to manufacture than other wind turbines. It is independent of wind direction and has a good start-up torque at lower wind speeds [91,92]. The installation of the Savonius turbine is shown in Fig. 12. It can be seen that the studied Savonius wind turbine has two semi-cylindrical blades without the center shaft. The end plates radius is set to $R = 1.25$ m (diameter $D = 2.5$ m), the semi-cylindrical blade diameter is 1.3573 m, and the overlap distance is 0.3396 m. The thickness of the blades and end plates is 2 mm. In addition, the entire length of the turbine is set to 5.0 m.

The flow direction of the wind keeps horizontally and the magnitude is 12 m/s, which is the typically rated speed of a wind turbine. The height of the step is set to 5.0 m (considering high-rise buildings of two or more storeys), and the role of the step is to induce vortex shedding. The vortex shedding could help accelerate the wind speed above the step when the wind flows across it. Compared to the conventional installation, a turbine installed above the step may generate more energy without changing its features. In addition, the horizontal position of the turbine 'x' and the vertical position 'y' are variable parameters. In this study, a total of twelve positions on the steps were selected for calculations to obtain values such as the torque of the turbine. Fig. 13 shows the turbine positions of all simulations.

As shown in Fig. 14, the computational domain consists of three sub-domains, with volumes from largest to smallest: the stationary region (indicated in violet), the wake region (indicated in green), and the rotating region (indicated in red). The stationary region is used to simulate a broad area of the surrounding environment; the wake region is used to simulate a flow field of the whole turbine at a closer location, and the rotating region is used to simulate the field near turbine surfaces. The flat surface case settings by simply removing the steps, and the rest remains the same. The computational domain of the flat surface case with a horizontal axis is shown in Fig. 15(a), and the case with a vertical axis (the turbine is situated asymmetrically close to the center of a sufficiently large domain) is shown in Fig. 15(b). Moreover, the summary of the numerical simulation settings is listed in Table 7.

5.4.3. Parameter definition

The power coefficient (C_p) of the Savonius wind turbine is the focus of this entire case study. It is defined in Ref. [93] as:

$$C_p = \frac{\text{Power of the turbine}}{\text{Available power in the wind}} = \frac{T \times \omega}{\frac{1}{2} \rho A U^3} \quad (1)$$

where T represents the torque produced by the turbine (N.m), ω represents the angular velocity (rad/s), ρ is the density of air (kg/m^3), A is the projected area of the turbine (m^2), and U is the incoming speed of the wind (m/s).

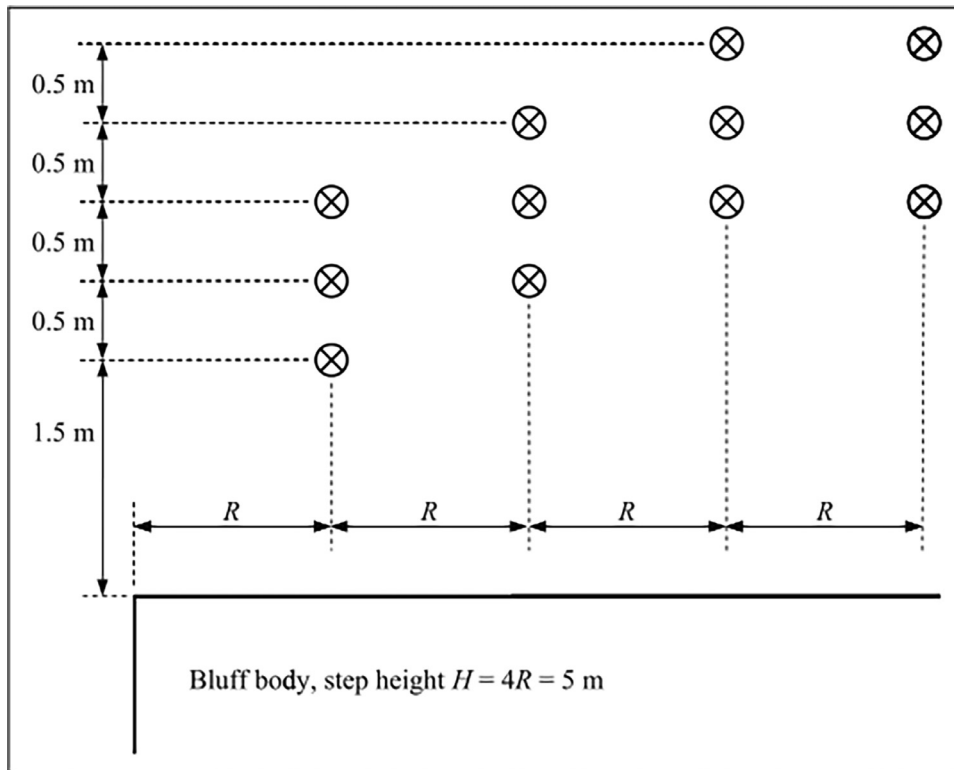

Fig. 13. Diagram of the turbine positions selected for simulation [89].

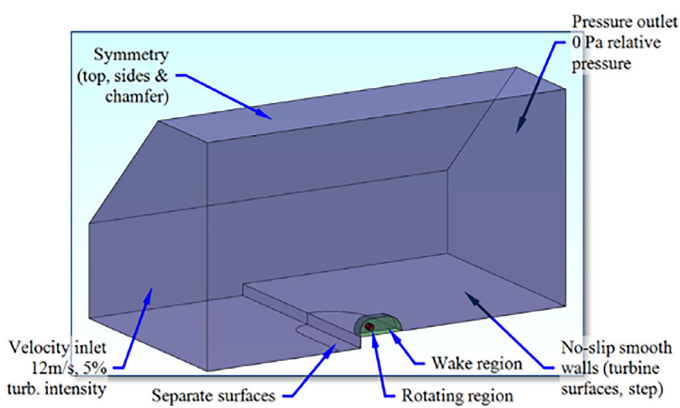

Fig. 14. Computational domain and boundary conditions for the case with the step height [89].

The tip speed ratio (λ) is defined as the ratio between the tangential speed of the tip of a turbine blade and the practical speed of the wind. It is defined in Ref. [93] as:

$$\lambda = \frac{R \times \omega}{U} \tag{2}$$

where R represents the radius of the turbine (m).

After combining Eqs. (1) and (2), the following Eq. can be obtained:

$$C_p = \frac{T \times \frac{\lambda U}{R}}{\frac{1}{2} \rho A U^3} = \frac{T \times \lambda}{\frac{1}{2} \rho A R U^2} \tag{3}$$

During the simulation, the settings such as ρ, A, R, U are kept constant. The setting for λ is varied from 0.6 to 1.6. T is the average torque between 1.5 and 2.5 revolutions for a given λ condition. More details can be gained from Ref. [89].

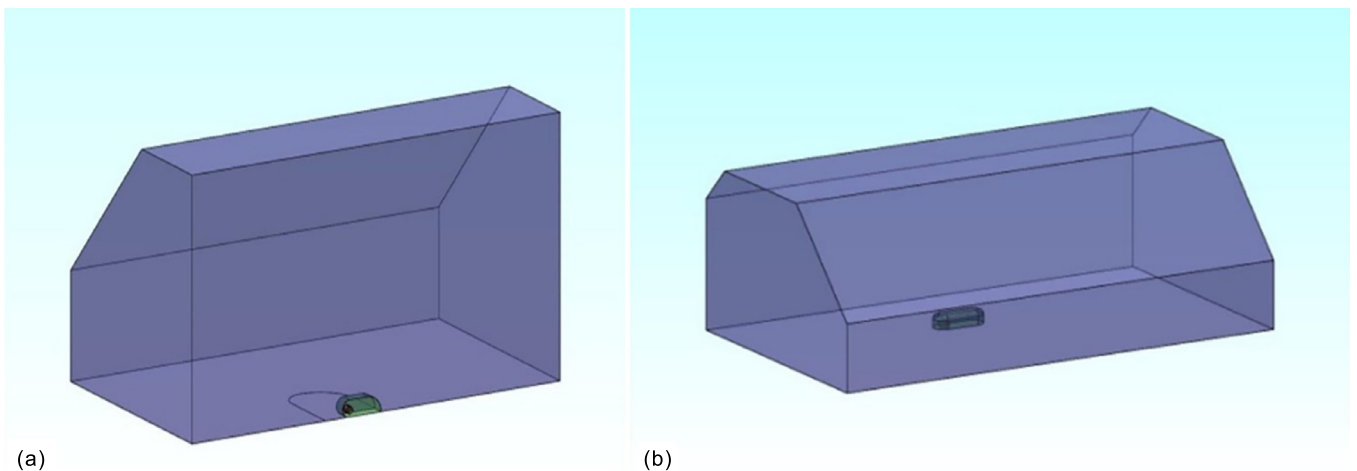

Fig. 15. Computational domain for (a) the case with the flat surface (axis hori.), and (b) the case with the flat surface (axis vert.) [89].

Table 7
Summary of the numerical simulation settings. Reproduced from Ref. [89].

No.	Description	Values and settings
1	Turbine surface cell face size	0.02D (D is the turbine diameter, D = 2.5 m)
2	Rotating region to wake region interface size	0.02D
3	Wake region cell body size	0.06D
4	Maximum cell face size	0.5D
5	Growth rate	1.1
6	Transient formulation	Second-order backward Euler
7	Time step	1/120 of rotational period
8	Advection scheme	High resolution (blend of upwind and central difference, with limits on the computed variable)
9	Turbulence model	Shear stress transport (SST)
10	Near wall treatment	Automatic switch between scalable wall functions and low reformulation
11	Fluid	Air at 25 °C
12	Pressure-velocity coupling	Rhie, Chow and Majumdar

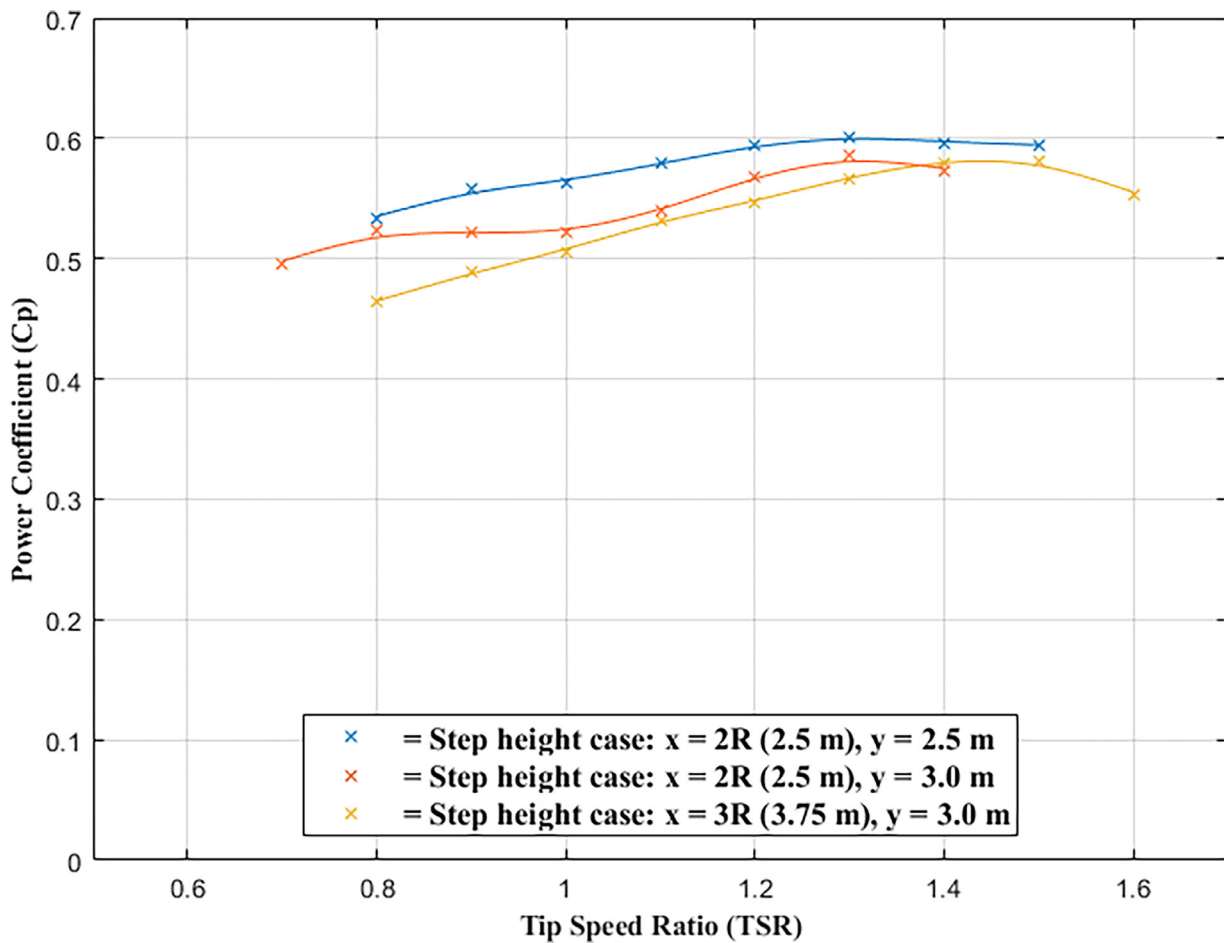

Fig. 16. Step height best three cases with corresponding positions. Reproduced from Ref. [89].

5.4.4. Results and discussion

The curves of C_p versus TSR are obtained by computing the turbine at different positions on the step height (i.e., different combinations of x and y) through a range of the TSR. Fig. 16 shows the best three curves with the top three C_p s. It can be noted that when installed the Savonius turbine above the step height in those three cases, the C_p s are essentially stable in the simulated TSR range between 0.5 and 0.6, with a maximum of 0.6 ($x = 2R, y = 2.5\text{ m}, \text{TSR} = 1.3$) and a minimum of about 0.47 ($x = 3R, y = 3.0\text{ m}, \text{TSR} = 0.8$). In addition, the turbine is simulated to operate in a similar setup on a flat surface. Three cases are simulated to determine the effect of the flat plate surface on performance: the lower half of the wind turbines [91–95] is returned (similar to the step height

case), the upper half of the turbine was returned, and the turbine is situated asymmetrically close to the center of a sufficiently large domain. In Fig. 17, it can be noted that the C_p s are essentially stable in the simulated TSR range between 0.15 and 0.25, with a maximum of about 0.23 (axis vert., $\text{TSR} = 1$), and a minimum of about 0.17 (lower half returning with axis hori., $\text{TSR} = 0.6$). The results of baseline cases are consistent with the results in Refs. [94–96], which demonstrates the accuracy of the present numerical simulations. In comparison, C_p is found to be 0.6 at the optimum mounting position when mounted above the bluff body, an improvement of approximately 200% compared to the baseline cases.

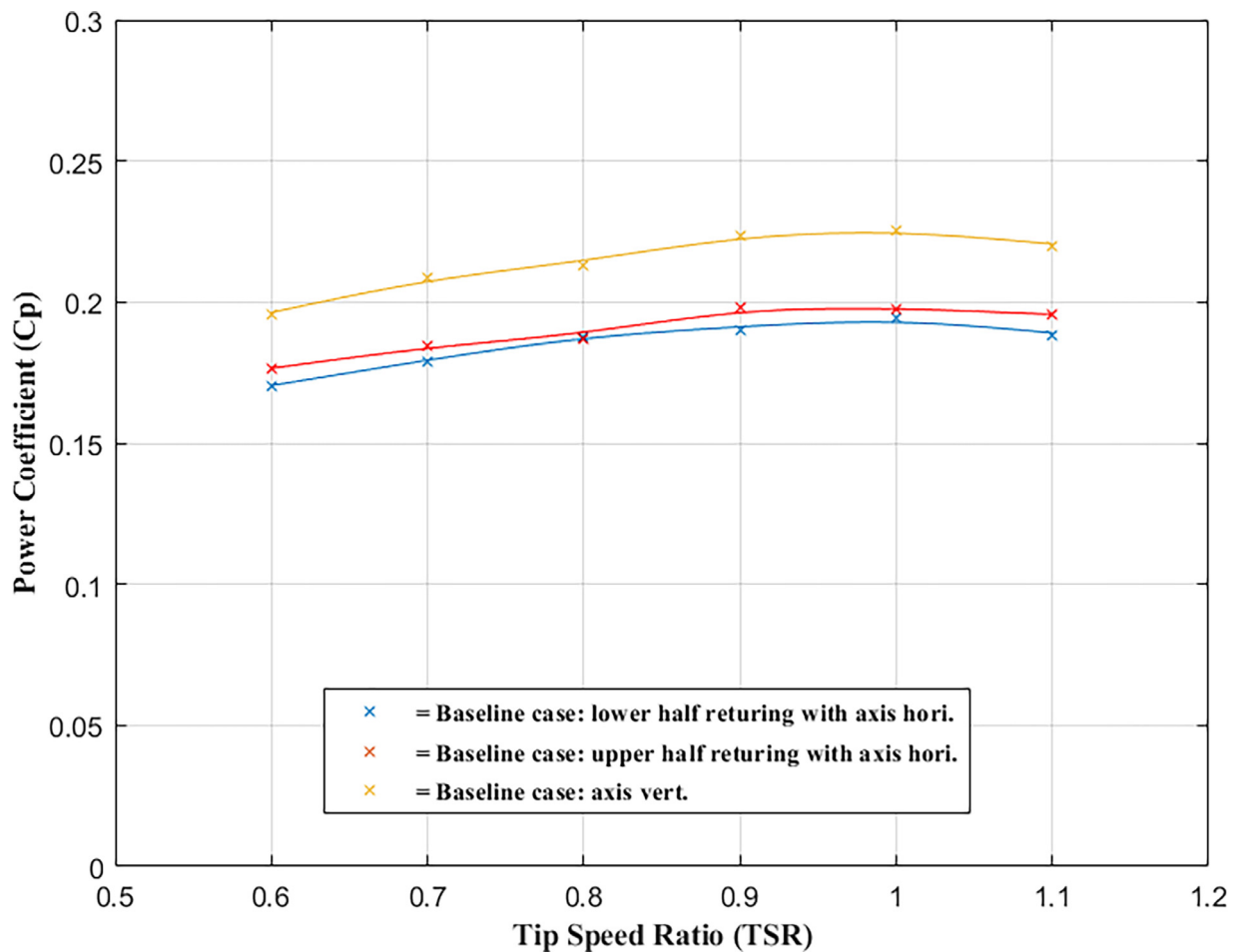

Fig. 17. Baseline cases with corresponding configurations. Reproduced from Ref. [89].

6. Conclusions

To conclude, since the demand for energy on a global scale has been showing an increasing trend, all countries attach great importance to the use of renewable energy. Wind energy has great potential for power generation, and it is a good choice. Compared with the use of non-renewable energy sources such as fossil fuels and coal for power generation, wind power generation is relatively simple and more environmentally friendly. In the future, wind energy will be of great significance to New Zealand's energy supply. Increasing the use of renewable energy can reduce dependence on energy imports. With more wind power, wind energy provides a reliable source of electricity and reduces reliance on seasonal weather patterns compared to hydroelectric power generation. The cost of wind energy is zero, which reduces New Zealand's dependence on fossil fuels and is not susceptible to changes in fossil fuel prices. Reliable power supply and prices will bring more economic benefits. The development of wind farms will create employment opportunities. People have lost their jobs due to Covid-19. If wind farms are expanded, more people will find jobs and have an economic income.

Reviewing the history and current situation of wind energy development in New Zealand, it can be seen that due to the increase in energy demand in New Zealand and the government's intention to achieve zero carbon emissions by 2050, the installation of wind turbines is showing a rapid growth trend. It is estimated that by 2030, wind power will account for at least 20% of New Zealand's electricity. New Zealand has a large amount of land available for wind farms. With the increase in turbine capacity and efficiency, wind technology has made considerable progress and has become a cost-effective way of generating electricity.

Wind power can become a key part of a safe and reliable power system. Accurate site assessment, optimization of turbine layout, adequate selection of turbine location, and more accurate scale determination to minimize costs while maximizing revenue will also promote successful wind energy project development.

It is evident from the research that all countries that use wind energy to generate electricity have some policies to support wind energy development. For these countries, their existing policies, such as fiscal incentives, capital subsidies, tax rebates, etc., have been widely used in renewable energy, potentially increasing the use of wind power in various countries, including most countries in Europe and China. Compared with these countries, New Zealand has fewer incentives for developing renewable energy, and there is no specific policy for wind energy. The high concentration of the industry is also an important factor hindering the entry of New Zealand wind power into the electricity market. At the same time, due to factors such as indigenous rights, environment, and society, New Zealand is also unable to make full use of high-quality wind energy. The wind farm approval process is complicated and slow. The approval process may take many years, bringing great uncertainty to local communities, governments, and developers. In summary, New Zealand's wind energy potential has not yet been fully tapped.

This article discusses the feasibility of small wind turbines in New Zealand, and introduces different types of turbines, as well as the operation and construction process of small wind turbines. It is concluded that some areas with high wind speeds in New Zealand are very suitable for promoting small-scale distributed generation (e.g., micro-generation). If New Zealand vigorously promotes small wind turbines, it will contribute to the rapid development of New Zealand's wind power genera-

tion. Small-scale wind farms will also reduce New Zealand's primary energy for electricity and emissions. Finally, through typical case studies, we also recognize the importance of the effective use of urban-specific structural parameters to enhance the effectiveness of small-scale wind turbines.

In the future, the New Zealand government should formulate policies related to wind energy development, address challenges related to wind energy development, financial incentives and subsidies, local support, and formulate effective wind energy implementation plans to stimulate and explore the use of wind energy fully. It is further necessary to describe the site-specific values and issues that need to be considered when planning and evaluating wind farm development, and be familiar with and able to deal with any issues related to wind farm proposals and consents, so New Zealand's wind energy industry will play a significant role in the field of renewable energy.

Data Availability

The data that support this present work are available from the corresponding author, upon reasonable request.

Declaration of Competing Interest

The authors declare that there is no conflicts of interest.

Acknowledgements

We gratefully acknowledge the financial support from the University of Canterbury, New Zealand (grant no. 452DISDZ) and Singapore National Research Foundation (grant no. NRF2016-NRF-NSFC001-102). The first author would like to thank the financial support by National Natural Science Foundation of China (51775188, 21805244) and Natural Science Foundation of Zhejiang Province (LQ21E060003, LZ21E060001). XL would like to thank to College of Engineering, University of Canterbury for providing his PhD studentship.

References

- [1] L. Li, L. Jian, W. Nianyuan, X. Shan, M. Chao, Z. Yanan, W. Xiaonan, Z. Yingru, Review and outlook on the international renewable energy development, *Energy Built Environ.* 3 (2022) 139–157.
- [2] B. Massimo, T. Torbjörn, A generic DFIG model for voltage dip ride-through analysis, *IEEE Trans. Energy Convers.* 28 (1) (2013) 76–85.
- [3] Markets team within the Evidence and Insight Energy in New Zealand 2020, Ministry of Business, Innovation & Employment, Wellington, 2020.
- [4] SBCEA Sustainable Energy Future for New Zealand by 2050, New Zealand Business Council for Sustainable Development, Wellington, 2003.
- [5] P. Stephen, S. Iain, Understanding New Zealand's wind resources as a route to 100% renewable electricity, *Renew. Energy* 170 (2021) 449–461.
- [6] Ministry of Economic Development Geothermal Energy: Summary of emerging technologies and barriers to development, Ministry of Economic Development, Wellington, 2010.
- [7] L. Luke, G. Margot, A. Cristina, A. Rosalind, Wind Energy Resource Assessment and Turbine Optimization in New Zealand, Department of Energy Resource Engineering, Stanford University, Stanford, 2009.
- [8] IRENA Future of wind: Deployment, investment, technology, grid integration and socio-economic aspects, International Renewable Energy Agency, Abu Dhabi, 2019.
- [9] I. Cumali, A. Hüseyin, B. Rasim, The current status of wind energy in Turkey and in the world, *Energy Policy* 39 (2) (2011) 961–967.
- [10] A. Berna, V. Gülin, Evaluating the role of renewable energy, economic growth and agriculture on CO₂ emission in E7 countries, *Int. J. Sustain. Energy* 39 (4) (2020) 335–348.
- [11] OJBP Energy Outlook: Global energy demand to grow 30% to 2035 Editors, OIL&GAS JOURNAL, 26 January 2017 [Online]. Available <https://www.oil&gas.com/general-interest/article/17288577/bp-energy-outlook-global-energy-demand-to-grow-30-to-2035> [Accessed 13 January 2022].
- [12] A.A. Luis, R. Edwin, S. Francisco, H. Victor, A Review and analysis of trends related to demand response, *Energies* 11 (7) (2018) 1617.
- [13] IEA Energy Policies of IEA Countries: New Zealand 2017, International Energy Agency, Paris, 2017.
- [14] L.-W. Jason, G. Amapola, Economic benefits of wind farms in New Zealand, *New Zealand Wind Energy Association*, Wellington, 2012.
- [15] NS Energy Staff Writer Profiling the top five countries with the highest wind energy capacity, *NS Energy*, 2021 30 March [Online]. Available <https://www.nsenerybusiness.com/features/top-countries-wind-energy-capacity/> [Accessed 13 January 2022].
- [16] S.C. Pryor, R.J. Barthelmie, A global assessment of extreme wind speeds for wind energy applications, *Nat. Energy* 6 (3) (2021) 1–9.
- [17] P. Jean-Daniel, Global Wind Installations, *Wind Energy International*, 2021 24 March [Online]. Available: <https://library.wwindea.org/global-statistics/> [Accessed 13 January 2022].
- [18] M. deCastro, S. Salvador, M. Gómez-Gesteira, X. Costoya, D. Carvalho, F.J. Sanz-Laruga, L. Gimeno, Europe, China and the United States: Three different approaches to the development of offshore wind energy, *Renew. Sustain. Energy Rev.* 109 (2019) 55–70.
- [19] L. Li, X. Ren, Y. Yang, P. Zhang, X. Chen, Analysis and recommendations for onshore wind power policies in China, *Renew. Sustain. Energy Rev.* 82 (2018) 156–167.
- [20] X. Chen, W.-J. Lee, Wind generation development in the US and China, *North American Power Symposium* 2010, 2010.
- [21] X. Yang, Z. Qian, Z. Wang, The research of investment and financing of wind power, 2010 World Non-Grid-Connected Wind Power and Energy Conference, 2010.
- [22] W. McDowall, P. Ekins, S. Radošević, L.-y. Zhang, The development of wind power in China, Europe and the USA: how have policies and innovation system activities co-evolved? *Technol. Anal. Strategic Manage.* 25 (2) (2013) 163–185.
- [23] E. Pyle, Case Study on The Development of the wind industry in New Zealand, *Asia-Pacific Economic Cooperation*, Singapore, 2016.
- [24] NZWEA Kiwi Success Story, *New Zealand Wind Energy Association*, 2022 [Online]. Available <https://www.windenergy.org.nz/wind-energy/nz-success> [Accessed 14 June].
- [25] PCEWind power, people, and place, *Parliamentary Commissioner for the Environment*, Wellington, 2006.
- [26] EECAR Review of New Zealand's wind energy potential to 2015, *Energy Efficiency and Conservation Authority*, Wellington, 2001.
- [27] I. Al-Bahady, An integrated wind and hydro power system using switched reluctance generator, *J. Power Energy Eng.* 6 (2) (2018) 1–19.
- [28] NZWEA Wind Generation in New Zealand, *New Zealand Wind Energy Association*, 2022 [Online]. Available <https://www.windenergy.org.nz/wind-energy> [Accessed 15 January].
- [29] K.A. Abed, A.A. El-Mallah, Capacity factor of wind turbines, *Energy* 22 (5) (1997) 487–491.
- [30] NZWEA Wind Farms Operating and Under Construction, *New Zealand Wind Energy Association*, 2022 [Online]. Available <https://www.windenergy.org.nz/operating-&-under-construction> [Accessed 16 January].
- [31] Meridian Energy Brooklyn wind turbine, *Meridian Energy*, 2022 [Online]. Available <https://www.meridianenergy.co.nz/who-we-are/our-power-stations/wind/brooklyn> [Accessed 16 January].
- [32] Genesis Energy Hau Nui Wind Farm, *Genesis Energy*, 2022 [Online]. Available: <https://www.genesisenergy.co.nz/assets> [Accessed 16 January].
- [33] Trust Power Trustpower Market Announcement, *Trust Power*, 15 May 2015 [Online]. Available <https://www.trustpower.co.nz/getting-to-know-us/company-news/2015/5/15/trustpower-market-announcement> [Accessed 16 January 2022].
- [34] Meridian Energy Te Apiti Wind Farm, *Meridian Energy*, 2022 [Online]. Available <https://www.meridianenergy.co.nz/who-we-are/our-power-stations/wind/te-apiti> [Accessed 16 January].
- [35] H. John F, C.A. Mecklenborg, C. Dongmei, P. Siddharth B, Wind energy conversion with a variable-ratio gearbox: design and analysis, *Renew. Energy* 36 (3) (2011) 1075–1080.
- [36] wind-turbine-models.com Wind turbines database, *wind-turbine-models.com*, 2022 [Online]. Available <https://en.wind-turbine-models.com/turbines> [Accessed 12 June].
- [37] Genesis Energy Taranaki windfarm energised, tilting New Zealand towards renewable future, *Genesis Energy*, 2020 17 November [Online]. Available <https://www.genesisenergy.co.nz/about/media/news/taranaki-windfarm-energised-tilting-new-zealand-t> [Accessed 18 January 2022].
- [38] R. Bristow, Construction of South Island's largest wind farm to start soon in Nth Canterbury, *Star News*, 2021 22 April [Online]. Available <https://www.odt.co.nz/star-news/star-districts/star-north-canterbury/construction-south-islands-largest-wind-farm-start> [Accessed 18 January 2022].
- [39] Power Technology Turitea Wind Farm, *Palmerston North, Power Technology*, 2019 10 December [Online]. Available <https://www.power-technology.com/projects/turitea-wind-farm-palmerston-north/> [Accessed 18 January 2022].
- [40] A. Trixl, The Renewable Energy Law Review: New Zealand, *The Law Reviews*, 2021 10 August [Online]. Available <https://thelawreviews.co.uk/title/the-renewable-energy-law-review/new-zealand> [Accessed 18 January 2022].
- [41] G. Kelly, Renewable energy strategies in England, Australia and New Zealand, *Geoforum* 38 (2) (2007) 326–338.
- [42] M. Barry, R. Chapman, Distributed small-scale wind in New Zealand: advantages, barriers and policy support instruments, *Energy Policy* 37 (9) (2009) 3358–3369.
- [43] NZWEA Wind Energy 2030 Document, *New Zealand Wind Energy Association*, Wellington, 2012.
- [44] R. Stock, Carbon credit price meltdown, 2013 *Stuff*, 3 February [Online] Available <http://www.stuff.co.nz/business/8252659/Carbon-credit-price-meltdown> [Accessed 18 January 2022].
- [45] M. Barry, Distributed Small Scale Wind in New Zealand: Advantages, Barriers and Policy Support Instruments, *Victoria University of Wellington*, Wellington, 2007.
- [46] M. Alcece, An analysis of the key environmental and social issues surrounding wind energy generation in New Zealand, *Lincoln Plan. Rev.* 8 (1-2) (2017) 69–74.
- [47] C. Warnock, The Outstanding Landscape Protection Society Inc. v. Hastings District Council, *Resour. Manage. Bull.* 7 (4) (2007) 41–42.

- [48] T. Daya-Winterbottom, Renewable Energy perspectives, IUCN Academy of Environmental Law 12th Colloquium, 2014.
- [49] S. Chiles, A new wind farm noise standard for New Zealand NZS 6808:2010, in: Proceedings of 20th International Congress on Acoustics, ICA 2010, Sydney, 2010.
- [50] R.G. Powlesland, Impacts of Wind Farms on Birds: a Review, Science for Conservation, Wellington, 2009.
- [51] R. Seaton, L.P. Barea, The New Zealand falcon and wind farms: a risk assessment framework, *N.Z. J. Zool.* 40 (1) (2013) 16–24.
- [52] EWGCase Studies on the Best Practices of Wind Energy Development in APEC Region, Energy Working Group, Singapore, 2016.
- [53] G.P. QC, Protecting New Zealand's environment: an Analysis of the Government's Proposed Freshwater Management and Resource Management Act 1991 reforms, New Zealand Fish & Game, Wellington, 2013.
- [54] L. Bob, S. Srikanth, Development challenges under the Clean Development Mechanism (CDM)—Can renewable energy initiatives be put in place before peak oil? *Energy Policy* 37 (1) (2009) 237–245.
- [55] G. Bertram, D. Clover, Chapter 14 - Kicking the Fossil-Fuel Habit: New Zealand's Ninety Percent Renewable Target for Electricity, in: *Generating Electricity in a Carbon-Constrained World*, Academic Press, New York, 2010, pp. 369–408.
- [56] H. Seamus, M. Richard, Vertical Integration and Market Power in Electricity Markets, Victoria University of Wellington Library, Wellington, 2007.
- [57] T. Couture, Y. Gagnon, An analysis of feed-in tariff remuneration models: Implications for renewable energy investment, *Energy Policy* 38 (2) (2010) 955–965.
- [58] PBTransmission to Enable Renewables Potential NZ Hydro Schemes, Parsons Brinckerhoff Associates Ltd, Wellington, 2007.
- [59] B. Tessa, Planning for Small Scale Wind Energy in New Zealand, University of, Otago, Dunedin, 2006.
- [60] GWECGlobal Wind 2018 Report, Global Wind Energy Council, Brussels, 2008.
- [61] PCEGet Smart, Think Small: Local Energy Systems for New Zealand, Parliamentary Commissioner for the Environment, Wellington, 2006.
- [62] R.M. Fisher, Wind Energy in New Zealand: regulatory and policy lessons to date, *N. Z. J. Environ. Law* 9 (2005) 307–335.
- [63] M. Wolsink, Attitudes and expectancies about wind turbines and wind farms, *Wind Eng.* 13 (4) (1989) 196–206.
- [64] EECAPower from the People: A Guide To Micro-Generation, Energy Efficiency and Conservation Authority, Wellington, 2010.
- [65] X. Jiang, C. Sun, L. Cao, N.-F. Law, K.H. Loo, Semi-decentralized energy routing algorithm for minimum-loss transmission in community energy internet, *Int. J. Electr. Power Energy Syst.* 135 (2022) 107547.
- [66] N. Reuther, J.-P. Thull, Feasibility Study of Small and Micro Wind Turbines for Residential Use in New Zealand, Lincoln University, Christchurch, 2011.
- [67] A. Tummalala, R.K. Velamati, D.K. Sinha, V. Indrajaya, V.H. Krishna, A review on small scale wind turbines, *Renew. Sustain. Energy Rev.* 56 (2016) 1351–1371.
- [68] M.S. Nazir, Y. Wang, M. Bilal, H.M. Sohail, A.A. Kadhem, H.M.R. Nazi, A.N. Abdalla, Y. Ma, Comparison of small-scale wind energy conversion systems: economic indexes, *Clean Technol.* 2 (2) (2020) 144–155.
- [69] S. Poletti, I. Staffell, Understanding New Zealand's wind resources as a route to 100% renewable electricity, *Renew. Energy* 170 (2021) 449–461.
- [70] J.-W. Wang, H.-J. Yang, J.-J. Kim, Wind speed estimation in urban areas based on the relationships between background wind speeds and morphological parameters, *J. Wind Eng. Ind. Aerodyn.* 205 (2020) 104324.
- [71] N. Mithraratne, Roof-top wind turbines for microgeneration in urban houses in New Zealand, *Energy Build.* 41 (2009) 1013–1018.
- [72] J. Smith, T. Forsyth, K. Sinclair, F. Oteri, Built-Environment Wind Turbine Roadmap, National Renewable Energy Laboratory, Golden, 2012.
- [73] GWAMean Wind Speed - New Zealand, The Global Wind Atlas, 2022 [Online]. Available <https://globalwindatlas.info/area/New%20Zealand> [Accessed 17 January].
- [74] J. Leary, H. Piggott, R. Howell, The Scraig wind trials – In situ power performance measurements of locally manufactured small wind turbines, *Wind Eng.* 45 (3) (2020) 727–749.
- [75] N. Isaacs, Energy in New Zealand houses: comfort, physics and consumption, *Build. Res. Inf.* 38 (5) (2010) 470–480.
- [76] InhabitatSWIFT: Ultra Quiet Rooftop Wind Turbine, Inhabitat, 2008 5 August [Online]. Available <https://inhabitat.com/swift-ultra-quiet-rooftop-wind-turbine/10737/> [Accessed 17 January 2022].
- [77] D. Infield, F. Li, Integrating micro-generation into distribution systems — a review of recent research, 2008 IEEE Power and Energy Society General Meeting - Conversion and Delivery of Electrical Energy in the 21st Century, 2008.
- [78] H.S. Kim, D.D.-C. Lu, Wind energy conversion system from electrical perspective - a survey, *Smart Grid Renew. Energy* 1 (3) (2010) 119–131.
- [79] F. Iov, F. Blaabjerg, Power electronics and control for wind power systems, 2009 IEEE Power Electronics and Machines in Wind Applications, Lincoln, 2009.
- [80] S.-H. Song, S.-i. Kang, N.-k. Hahn, Implementation and control of grid connected AC-DC-AC power converter for variable speed wind energy conversion system, Eighteenth Annual IEEE Applied Power Electronics Conference and Exposition, 2003, APEC '03, Miami Beach, 2003.
- [81] Y. Chang, X. Mao, Y. Zhao, S. Feng, H. Chen, D. Finlow, Lead-acid battery use in the development of renewable energy systems in China, *J. Power Sources* 191 (1) (2009) 176–183.
- [82] R. Siddaiah, R.P. Saini, A review on planning, configurations, modeling and optimization techniques of hybrid renewable energy systems for off grid applications, *Renew. Sustain. Energy Rev.* 58 (2016) 376–396.
- [83] F. Wang, L. Bai, J. Fletcher, J. Whiteford, D. Cullen, Development of small domestic wind turbine with scoop and prediction of its annual power output, *Renew. Energy* 33 (7) (2008) 1637–1651.
- [84] M.M.A. Bhutta, N. Hayat, A.U. Farooq, Z. Ali, S.R. Jamil, Z. Hussain, Vertical axis wind turbine – A review of various configurations and design techniques, *Renew. Sustain. Energy Rev.* 16 (4) (2012) 1926–1939.
- [85] J.V. Akwa, H. AntonioVielmo, A.P. Petry, A review on the performance of Savonius wind turbines, *Renew. Sustain. Energy Rev.* 16 (5) (2012) 3054–3064.
- [86] N. Bourabaa, E. Delacourt, J.-L. Menet, Wind potential evaluation around isolated pitched roof buildings, *J. Renew. Sustain. Energy* 7 (2) (2015) 023111.
- [87] A. Mani, K. Amini, 3D-CFD Study of oblique streamlining membranes on the roof-top of a low-rise building, targeting pedestrian comfort—a case study, *Green Build. Constr. Econ.* 1 (1) (2020) 51–68.
- [88] F. Schily, M. Paraschivoiu, CFD Study of a Savonius Wind Turbine on a Rooftop, CFDSC, Waterloo, 2015.
- [89] S.C. Goh, J.U. Schlüter, Numerical simulation of a Savonius turbine above an infinite-width forward facing step, *Wind Eng.* 40 (2) (2016) 134–147.
- [90] S.C. Goh, S.R. Boopathy, C. Krishnaswami, J.U. Schlüter, Tow testing of Savonius wind turbine above a bluff body complemented by CFD simulation, *Renew. Energy* 87 (2016) 332–345.
- [91] D. Zhao, N. Han, Optimizing overall energy harvesting performances of miniature Savonius-like wind harvesters, *Energy Proc.* 178 (2018) 311–321, doi:10.1016/j.enconman.2018.10.012.
- [92] D. Zhao, N. Han, E. Goh, J. Cater, A. Reinecke, *Wind Turbines and Aerodynamics Energy Harvesters*, Academic Press, London, 2019.
- [93] N. Han, D. Zhao, J. Schluter, Performance evaluation of 3D printed miniature electromagnetic energy harvesters driven by air flow, in: Dan Zhao (Ed.), *Applied Energy*, 178, Elsevier, 2016, pp. 672–680, doi:10.1016/j.apenergy.2016.06.103.
- [94] R.E. Sheldahl, B.F. Blackwell, L.V. Feltz, Wind tunnel performance data for two- and three-bucket savonius rotors, *J. Energy* 2 (3) (1978) 160–164.
- [95] U.K. Saha, M.J. Rajkumar, On the performance analysis of Savonius rotor with twisted blades, *Renew. Energy* 31 (11) (2006) 1776–1788.
- [96] T. Zhou, D. Rempfer, Numerical study of detailed flow field and performance of Savonius wind turbines, *Renew. Energy* 51 (2013) 373–381.