

# **USING A COLLISION RISK MODEL TO ASSESS BIRD COLLISION RISKS FOR OFFSHORE WINDFARMS**

**MARCH 2012**

**Bill Band**

This guidance has been prepared for The Crown Estate as part of the Strategic Ornithological Support Services programme, project SOSS-02. It provides guidance for offshore wind farm developers, and their ecological consultants, on using a collision risk model to assess the bird collision risks presented by offshore windfarms.

The guidance has been extended in this March 2012 version to make use of flight height distribution data, where that data is available and robust; and to include a methodology for considering birds on migration, for which survey data on flight activity may be limited.

The guidance is accompanied by

- a Collision Risk Spreadsheet, which enables the calculations required to be undertaken and presented in a standardised manner
- a Worked Example, to illustrate the process
- a Tidal Variation spreadsheet, for use only when tidal effects may be significant

## ACKNOWLEDGEMENTS

The idea and scope for this project was developed by the Strategic Ornithological Support Services (SOSS) steering group. Work was overseen by a project working group comprising Ian Davies (Marine Scotland), Ross McGregor (SNH), Chris Pendlebury (Natural Power, nominated by SeaEnergy) and Pernille Hermansen (DONG Energy), together with Bill Band. We thank the project working group and other members of the SOSS steering group for many useful comments which helped to improve this report. SOSS work is funded by The Crown Estate and coordinated via a secretariat based at the British Trust for Ornithology. More information is available on the SOSS website [www.bto.org/soss](http://www.bto.org/soss).

The SOSS steering group includes representatives of regulators, advisory bodies, NGOs and offshore wind developers (or their consultants). All SOSS reports have had contributions from various members of the steering group. However the report is not officially endorsed by any of these organisations and does not constitute guidance from statutory bodies. The following organisations are represented in the SOSS steering group:

SOSS Secretariat Partners:	The Crown Estate British Trust for Ornithology Bureau Waardenburg Centre for Research into Ecological and Environmental Modelling, University of St. Andrews
Regulators:	Marine Management Organisation Marine Scotland
Statutory advisory bodies:	Joint Nature Conservation Committee Countryside Council for Wales Natural England Northern Ireland Environment Agency Scottish Natural Heritage
Other advisors:	Royal Society for the Protection of Birds
Offshore wind developers:	Centrica (nominated consultant RES) Dong Energy Eon (nominated consultant Natural Power) EdF Energy Renewables Eneco (nominated consultant PMSS) Forewind Mainstream Renewable Power (nominated consultant Pelagica) RWE npower renewables (nominated consultant GoBe) Scottish Power Renewables SeaEnergy/MORL/Repsol (nominated consultant Natural Power) SSE Renewables (nominated consultant AMEC or ECON) Vattenfall Warwick Energy

<b>Acknowledgements</b>	<b>Page</b>	<b>2</b>
<b>Purpose of guidance</b>	<b>Paragraph</b>	<b>1</b>
<b>Information needed</b>		<b>5</b>
<b>Collision risk model</b>		<b>8</b>
General features		10
<b>Stage A – Flight activity</b>		<b>17</b>
How flight activity is expressed		18
Density of birds in flight and at risk		20
Flight heights		25
Daylight hours and nocturnal activity		32
<b>Stage B – Estimating number of bird flights through rotors</b>		<b>36</b>
<b>Stage C – Probability of collision for a single rotor transit</b>		<b>39</b>
Wind turbine speed		48
Accuracy of model		50
Possible refinements		51
<b>Stage D – Multiplying to yield expected collisions per year</b>		<b>52</b>
Units		53
Non-operational time		54
Large turbine arrays		55
<b>Extended model taking account of flight height</b>		
Effects of taking flight height into account		61
When to use generic flight height data		62
The hard stuff (ie maths)		65
The easy stuff (how to do the calculation)		74
<b>Stage E – Avoidance and attraction</b>		<b>76</b>
Avoidance		76
Attraction		84
<b>Stage F - Expressing uncertainty</b>		<b>86</b>
<b>Footnote</b>		<b>96</b>
<b>Notes on using the spreadsheet</b>	<b>Page</b>	<b>31</b>
<b>Annex 1 – Oblique approach</b>		<b>36</b>
<b>Annex 2 – Relationship between bird flux and bird density</b>		<b>38</b>
<b>Annex 3 – Single transit collision risk</b>		<b>40</b>
<b>Annex 4 – Large turbine arrays</b>		<b>44</b>
<b>Annex 5 - Using flight height distributions –     derivation of equations</b>		<b>46</b>
<b>Annex 6 - Assessing collision risk for birds on migration</b>		<b>48</b>
<b>Annex 7 - Taking account of tidal variation</b>		<b>52</b>
<b>Annex 8 - Notes on spreadsheet Visual Basic functions</b>		<b>60</b>
<b>References</b>		<b>61</b>

## PURPOSE OF GUIDANCE

1. Offshore windfarms may have a number of effects on bird populations:
  - **Displacement** – birds may partially or totally avoid a windfarm and hence be displaced from the underlying habitat.
  - **Barrier effects** – birds may use more circuitous routes to fly between, for example, breeding and foraging grounds, and thus use up more energy to acquire food.
  - **Habitat effects** – birds may be attracted or displaced by changes in marine habitats and prey abundance as a consequence of the windfarm.
  - **Collision risk** – birds may be injured or killed by an encounter or collision with turbines or rotor blades.

This guidance relates to the last of these, collision risk.

2. **An environmental statement for an offshore windfarm should include a quantitative estimate of collision risk for all bird species present on the site for which the level of risk has the potential to be important. The environmental statement should provide a view on the significance of that collision risk on the respective bird populations.**
3. The aim of this guidance is to promote a standardised approach to collision risk assessment for offshore windfarms, to increase the transparency of calculations, and hence promote greater confidence in the results; to enable estimates from different windfarms to be more easily compared and combined so as to facilitate cumulative assessment; and hence enable collision risk assessment to be used as a tool in selecting the best areas for offshore windfarm development.
4. The guidance describes the information needed, and how to use that information, to arrive at an estimate of collision risk. It is accompanied by a spreadsheet which enables the necessary calculations to be performed in a standardised way.

## INFORMATION NEEDED

5. Figure 1 shows the information needed to estimate collision mortality:
  - **information derived from bird survey** - on the number of birds flying through or around the site, and their flight height
  - **bird behaviour** - prediction of likely change of behaviour of birds, eg in avoiding, or being attracted to, the windfarm
  - **turbine details** - physical details on the number, size and rotation speed of turbine blades
  - **bird details** - physical details on bird size and flight speed
6. This guidance sets out how that information should be presented and used within a collision model, and how the outputs from that model should be expressed – ie the components in the dashed 'box' in Figure 1. The guidance does not cover:
  - bird survey methods - for which there are various advisory sources.
  - bird behaviour - while it outlines how an avoidance rate factor should be used in the collision risk calculation, the guidance leaves it to other sources, where possible based on actual monitoring of bird collisions at windfarms, to advise on what avoidance rates should be used.

Figure 1 also indicates the key outputs from the collision model – the collision risk, expressed in terms of the likely number of birds per month or per year which will collide with the windfarm, and the range of uncertainty surrounding that estimate. These should be

accompanied by a clear statement of the assumptions on avoidance made in arriving at that estimate, as such assumptions are often be critical to the magnitude of the collision estimate. This guidance includes advice on how these outputs should be presented.

- Note that the collision risk model stops at an assessment of collision risk. Where collision risk is not negligible, a developer will need to further consider the significance of the predicted mortality - which will depend on the sensitivity of the bird population, and the degree of protection afforded by legislation and any protected sites in the vicinity which may be designated for that species.

**Fig 1: Role of collision risk model**

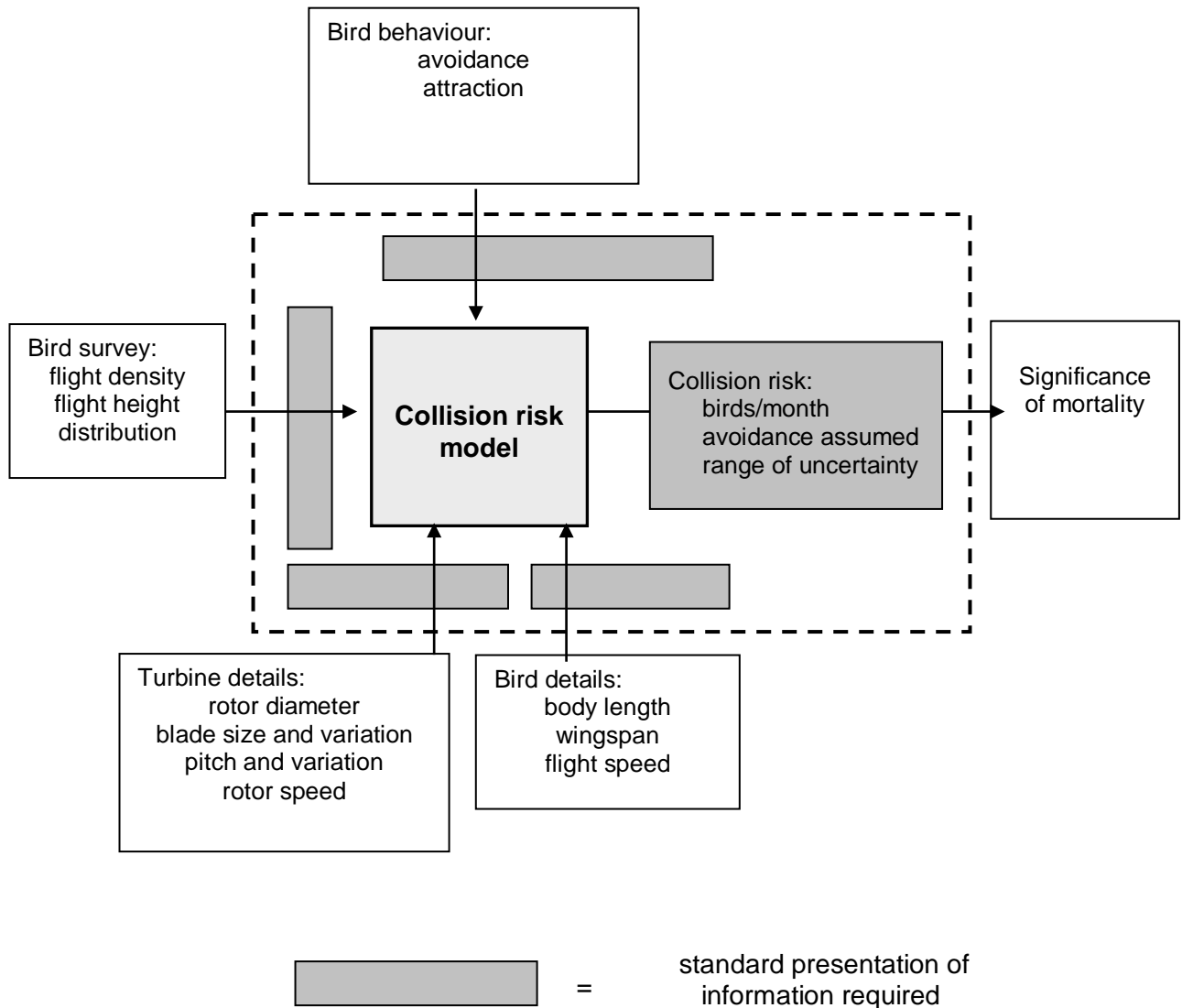

## COLLISION RISK MODEL

8. The approach adopted follows in general terms that developed by Band (2000)<sup>i</sup> and Band et al (2007)<sup>ii</sup> and promoted in guidance published by Scottish Natural Heritage, but it has been updated to facilitate application in the offshore environment. The offshore approach differs from onshore mainly in the methods used to gather and present information on flight activity, given that direct observations of birds from key vantage points are not usually possible in the marine environment. The approach is described below in six stages:
  - Stage A assemble data on the number of flights which, in the absence of birds being displaced or taking other avoiding action, or being attracted to the windfarm, are potentially at risk from windfarm turbines;
  - Stage B use that flight activity data to estimate the potential number of bird transits through rotors of the windfarm;
  - Stage C calculate the probability of collision during a single bird rotor transit;
  - Stage D multiply these to yield the potential collision mortality rate for the bird species in question, allowing for the proportion of time that turbines are not operational, assuming current bird use of the site and that no avoiding action is taken;
  - Stage E allow for the proportion of birds likely to avoid the windfarm or its turbines, either because they have been displaced from the site or because they take evasive action; and allow for any attraction by birds to the windfarm eg in response to changing habitats; and
  - Stage F express the uncertainty surrounding such a collision risk estimate.
9. The basic model has recently (March 2012) been extended to make use, where it is available, of data on the distribution of bird flight heights; in particular to enable use of the data on flight heights of birds at sea compiled for SOSS by Cook et al<sup>iii</sup>. This 'extended model' is described following Stage D, as within that model Stages B, C and D become merged in a single calculation. Another addition is Annex 6, which describes use of the model when assessing the collision risk to birds on migration, where there may be limited bird survey information on flight activity.

### General features

10. Risk is turbine-based. Risk in this model is calculated directly from the rotor parameters and the flight activity in the airspace surrounding each turbine. Some practitioners have used an approach which considers the risk to each bird passing through a windfarm, taking account of the layout and spacing of turbines to calculate the likelihood of encountering one or more turbines and the resulting risk. This is unnecessary if one focuses, as in this guidance, on the risk resulting from each turbine operating within its own airspace within which there is a known (or projected) level of flight activity.
11. Relationship to previous guidance. The approach to quantifying and expressing flight activity in this guidance differs from that set out in the earlier Band papers. These papers offered two alternative approaches for calculating the likely number of flights through turbines: the first using observations of bird flux passing through a vertical 'risk window' enveloping the turbines; and the second assessing the 'bird occupancy' of the volume of airspace occupied by the windfarm as a whole. Both these methods are mathematically equivalent to the method described below and in the attached spreadsheet, in which the core measures of flight activity used are the density of flying birds per unit horizontal area of the windfarm, and the proportion flying at turbine height. The current approach leads to the same results and avoids the need to identify arbitrary risk windows or to define an arbitrary windfarm boundary. The basic model and spreadsheet used to calculate the risk for a single bird flight through a rotor are also as in the earlier papers (though subject to minor refinement). Thus, collision

risk estimates resulting from application of the basic model in this guidance should not differ substantively from those deriving from correct application of the earlier Band papers.

12. Oblique approach simplified. There is a simplification involved in separating out Stages B and C, in assuming that the probability of collision for any bird passing through a rotor is the same regardless of the direction of flight. In fact, the collision risk depends to some extent on a bird's angle of approach, determined by the direction of its flight and the orientation of the turbine blades. A bird approaching a turbine at an oblique angle is exposed both to a reduced probability of flying through the rotor, because the rotor presents an elliptical rather than circular cross-section, and an increased risk of collision if it does so. The model adopted for use here assumes that these two factors exactly offset each other, such that all bird transits can be treated as if making perpendicular approach to the rotor. This enables Stages B and C to be undertaken sequentially. A more exact approach would require estimating the number of flights from each direction, applying the collision probability for that direction, and summing the probability over all directions. Annex 1 provides a fuller explanation of this issue and the justification for adopting the simplified approach. It should be recognised that this simplification leads to some underestimation of collision risk, which may be as much as 10% for large birds.

13. Taking account of bird flight height distribution. Seabirds mostly fly at relatively low heights over the sea surface. The height distribution varies from species to species and may depend on the site and its ecology and related bird behaviour. The basic model considers the risk only to birds flying at risk height (above the minimum and below the maximum height of the rotors) and of these, only those which pass through the rotors. However within these limits it assumes a uniform distribution of bird flights. There are three consequences of a skewed distribution of flights with height:

- the proportion of birds flying at risk height decreases as the height of the rotor is increased;
- more birds miss the rotor, where flights lie close to the bottom of the circle presented by the rotor; and
- the collision risk, for birds passing through the lower parts of a rotor, is less than the average collision risk for the whole rotor.

This guidance now includes, in addition to the basic model, an extended model (March 2012) which enables flight height distributions to be incorporated in the calculation, for use in circumstances where flight height data is available and adequately robust.

14. Best estimate not worst-case. This guidance does not recommend use of 'worst case' assumptions at every stage. These can lead to an overly pessimistic result, and one in which the source of the difficulty is often concealed. Rather, it is recommended that 'best estimates' are deployed, and with them an analysis of the uncertainty or variability surrounding each estimate and the range within which the collision risk can be assessed with confidence. In stating such a range, the aspiration should be to pitch that at a 95% confidence level, that is, so that there is 95% likelihood that the collision risk falls within the specified range. However, given the uncertainties and variability in source data, and the limited firm information on bird avoidance behaviour, it seems likely that for many aspects the range of uncertainty may have to be the product of expert judgement, rather than derived from statistical analysis.

15. Spatial exploration of risk. While this guidance, and the attached spreadsheet, is written around quantifying the collision risk from an entire windfarm, it can equally well be applied at the level of a subgroup of turbines or even an individual turbine. If the data on flight activity is sufficiently robust to allow such discrimination, this facilitates the examination of risk on a spatial basis. Collision risk is directly proportional to flight activity which is dependent on bird density at rotor risk height. Siting windfarms, or groups of turbines, in areas of lower bird density is likely to yield a proportionately lower collision risk.

16. Use for onshore windfarms. The approach described here could equally well be applied to onshore as to offshore windfarms, using vantage point or other land-based survey or radar to generate the required data on bird density (see paragraph 19).

## STAGE A - FLIGHT ACTIVITY

17. The aim of this stage is to estimate the number of flights which, in the absence of birds being displaced or taking other avoiding action, or being attracted to the windfarm, would potentially be at risk from the windfarm turbines. This requires field data to determine levels of flight activity within the proposed windfarm.

### How flight activity is expressed

18. Flight activity may be expressed in a variety of ways.

- Bird density is a measure of how many birds (of any given species) are in flight at one time. It may be expressed in terms of birds per m<sup>3</sup> (cubic metre) of air space (the 'true density' D<sub>v</sub>). However, more commonly, reflecting the use of boat-based or aerial survey techniques, it may be expressed on an area basis as the total number of birds in flight at any height at a given point of time, per m<sup>2</sup> (square metre) or per km<sup>2</sup> (square kilometre), as viewed from the air, D<sub>A</sub>.
- Bird occupancy applies to a given volume of airspace, and is simply the number of birds on average occupying that volume. Thus, in a volume of air for which the bird density is uniform, bird occupancy (birds) = true density (birds/ m<sup>3</sup>) x volume (m<sup>3</sup>). The concept of 'bird occupancy' is not used in this guidance, but is referred to here to facilitate comparison with the Band (2000) model<sup>1</sup>.
- Bird flux is the number of birds crossing an imaginary surface within the airspace, expressed as birds/sec or birds/sec per m<sup>2</sup> of that surface. It is commonly measured in the field in terms of a Mean Traffic Rate which is the number of birds flying per hour across an imaginary horizontal line of length 1km. If all birds crossing that imaginary line, as viewed from above or below, are recorded at any flight height up to height h metres, then the Mean Traffic Rate is the total number of birds N birds/km/hour crossing that line. MTR must be divided by 3600 (seconds in an hour) and 1000 (metres in a km) to express bird flux in birds/sec per metre of baseline, and divided further by the height h to get the bird flux in birds/ sec /m<sup>2</sup>.

Bird flux is directly related to bird density, but depends on the speed of the birds (if they were stationary, there would be no flux). If the total bird flux (flights at any height, in either direction) across the baseline is F<sub>L</sub> birds/sec per metre of baseline, then the bird density D<sub>A</sub> per m<sup>2</sup> is

$$D_A = (\pi/2) F_L / v$$

where v is the speed of the birds in m/sec: see Annex 2 for the derivation of this formula and fuller information on converting between flux and bird density.. Flux is directional – for a given density of birds moving in random horizontal directions, a vertical 'window' will intercept more birds flying perpendicular to the area than birds flying at an oblique angle, to which the window will appear narrower. The (π/2) factor takes account of this angle-dependence.

---

<sup>1</sup> In the Band (2000) model, bird occupancy is expressed in 'bird-seconds per year' as a convenient way of expressing low levels of bird occupancy. An occupancy of 31.6 x 10<sup>6</sup> bird-seconds per year means that on average, within the specified volume, there is one bird throughout the year, 31.6 x 10<sup>6</sup> being the number of seconds in a year.



**Fig 2: Boat-based survey – snapshot counts of birds in flight**

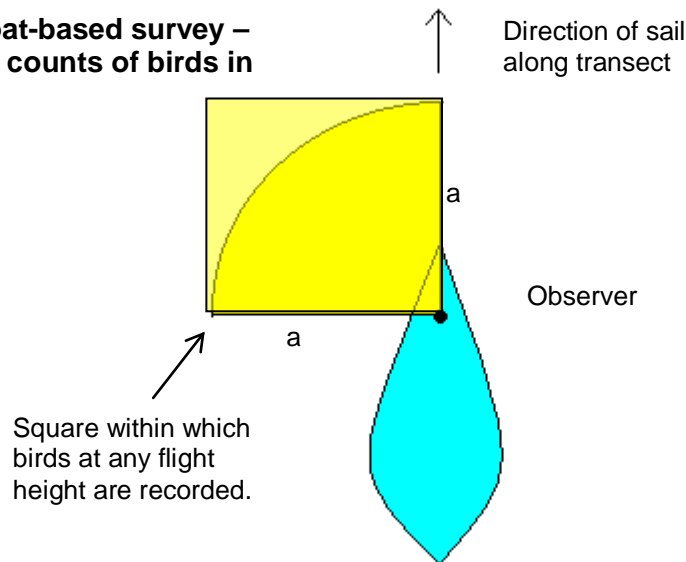

19. How flight activity is expressed in output from surveys often reflects the type of survey method deployed:

- Boat-based surveys, where the boat follows a transect through the site, and records are taken at intervals of birds in flight, provide a 'snapshot' of the number of birds in flight within the range of observation (see diagram) which is usually 300m. If a snapshot has  $N$  birds (at any flight height) within an observation square of side  $a$  from the boat then the bird density per unit area of sea is  $N / a^2$  (see Fig 2). Some surveyors record flights on both sides of the boat, thus covering two such squares, such that the density is  $N / (2 a^2)$ . Other surveyors record flights over a quadrant area of sea of radius  $a$ , in which case the density is  $N / (\pi a^2/4)$ .

Boat-based survey can also provide information on flight heights, such as to enable an estimate of the proportion of flights which fall within the rotor risk height (from the lowest point to the highest point of a rotor, a height equal to twice the rotor radius. Cowrie guidance on boat-based survey methods is provided in Camphuysen et al (2004)<sup>iv</sup>.

- Aerial survey methods, whether photographic or not, provide a direct sampling measure of the density of birds in flight per unit area of sea, provided that birds in flight can be discriminated from those on the sea surface, and that species can be identified at an adequate level.

- Radar survey methods which observe bird transits across a radar platform provide a measure of bird flux, ie the number of birds crossing an imaginary vertical surface, defined by a horizontal line between two points and the vertical surface extending from the sea upwards through that line. In practice, vertical radar typically allows most effective scanning of birds crossing two vertical windows of base around 500m, which may be divided into altitude bands (see diagram). Observations both at close range and at large distances, where detection rates degrade, are discarded. Adding the birds crossing each of these windows gives the bird flux across an imaginary baseline of 1km length (eg see report for Bureau Waardenburg, Krijgsveld et al. (2008)<sup>9</sup>).

**Fig 3: Vertical radar survey**

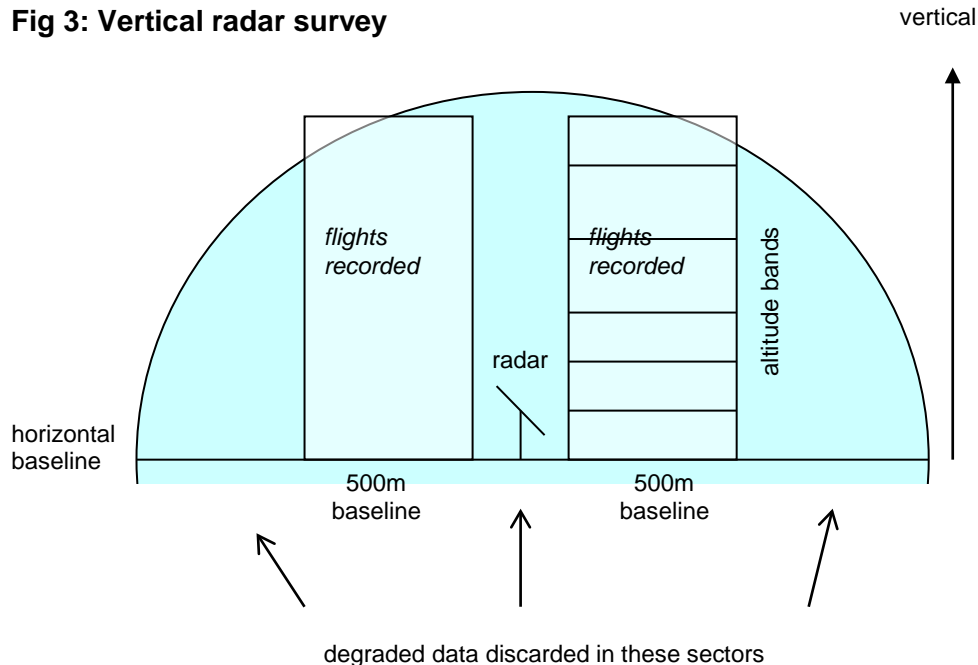

- Vantage point survey methods which record all bird flights in a defined volume of the windfarm airspace from a key vantage point lead to a measure of bird occupancy in that volume. Such survey is not normally practicable at sea unless a semi-permanent observation platform is installed, or if the relevant sea area can be observed in its entirety from shore. Bird occupancy is readily converted to bird density (per m<sup>2</sup>) by dividing by the area scanned from the vantage point (see paragraph 18).

### Density of birds in flight and at risk

20. For the purpose of estimating collision risk, this guidance starts from measurements, derived from survey information, of bird density, and of the proportion of birds flying at risk height (ie between the lowest and highest points of the rotors) or, if more detailed observations are available, of the distribution of bird density with height. The calculations set out later use that information to calculate the flux of birds through each rotor (using the simplifying assumption that flight direction is perpendicular to the rotors).
21. The most useful way to present information on bird density is on an area basis, ie the total number of birds in flight at any height at a given point in time, per square kilometre (km<sup>2</sup>). Stating the bird density per unit area provides a better basis for comparison of risk assessments, and for cumulative risk assessment, than would be the case if only bird flight density at rotor height were stated. It also provides a level of data which can be re-interpreted

in the future, for example if a new generation of larger turbines came available. Such overall bird density information does not embody assumptions or uncertainties relating to flight height distribution. Where survey information is based directly on measurements of flux (eg from use of radar survey methods) then these should be translated, using the formula in paragraph 18, to estimates of bird density.

22. **An Environmental Statement should clearly state the bird density used in collision calculations, expressed in terms of birds per km<sup>2</sup> across the site, counting birds flying at all heights. It should also state the proportion of birds estimated to be flying within the risk height band – ie between the lowest and highest points of the rotors. Where a bird flight height distribution is used in the calculation, the Environmental Statement should state the distribution used and its source.** Where survey information leads to a range of perspectives on bird density (eg including or excluding data for buffer areas), the Environmental Statement should make clear which survey data has been used, and why. Paragraphs 25-31 describe how information on flight heights should be presented.
23. The number of birds of any one species passing through a rotor is, among other factors, proportional to the density of flying birds in the vicinity of the rotor, and hence so too is the collision risk to which they are exposed. Therefore, where one of the aims of a collision risk assessment is to choose a windfarm location and design so as to minimise bird collision risks, the starting point should be to select those areas with the lowest density of the bird species vulnerable to collision. For large sites, or for consideration of collision risks at a strategic level, it may be possible to discriminate between different zones of the site or areas with different bird densities. Such information will be helpful in identifying preferred zones for development. However care should be taken to ensure that any differences are statistically significant. For most development sites, the statistical variation in the data derived from survey is likely to mask any within-site variations in bird density.
24. While the approach to collision risk in this guidance does not require definition of a windfarm boundary, and the area of the windfarm area does not feature in the calculations, it is important to be clear as to the boundary within which an estimate of bird density applies. Survey recommendations usually recommend survey wider than the windfarm itself so as to ensure that any bird density estimates for the wind farm site are adequately representative of the marine area as a whole.

### **Flight heights**

25. There is only a risk of collision with turbine blades at flight heights between the lowest and highest points of the rotors, a total height  $2R$ , twice the length of a blade. Therefore an important parameter to estimate is the proportion  $Q_{2R}$  of birds flying within that risk height band. The data on bird density should be accompanied by an estimate of the proportion of birds flying within the risk height band for the proposed windfarm.
26. If data is available on the distribution of bird flight density with height, that enables the calculation to be refined to allow for the fact that most flights within this risk height are at a height where the chance of passing through the rotor is low, and the actual risk of collision if they do is also lower than for an average rotor transit. Most seabirds spend a high proportion of their flight time quite close to the sea surface, and therefore any collision risk tends to be concentrated in the lower parts of the rotor<sup>vi</sup>.
27. Accurate data on flight heights is difficult to capture. In boat-based surveys, it relies on observers being able to estimate flight heights, and the accuracy of such estimates decreases with height. While aerial survey in the past has not normally yielded flight height information, high definition digital photography systems are now available which provide increasingly accurate information on flight height.
28. For some species, survey information at a site may be insufficient to provide a reasonably precise figure for the proportion of birds flying at risk height. Where this is the case, it may be

better to use a generic view of flight height behaviour, obtained by combining flight height information gathered from surveys at different sites – for which a detailed report has been compiled by Cook et al (BTO) for SOSS<sup>iii</sup>. In combining results from different surveys, care is needed to place greatest weight on those with the most robust data, which may imply discarding data with poor levels of precision. The generic information should be reviewed, assessing whether it provides more precise information than the site-based data, and whether the site-based data, if limited, is nonetheless compatible with the generic information. If so, then the generic information should be used. Care must however be taken not to mask any feature of flight behaviour at the site in question which could reflect a genuine difference of behaviour due to environmental variables or the specific use of the site made by the birds. For some species typical flight heights are dependent on the season, and in such a case it will be best to use seasonally dependent typical flight heights in assessing collision risk for each month, rather than average flight heights across the year.

29. Often, at the time of undertaking field survey, the actual turbines to be used have not been selected, and turbine models may vary in their risk height. Estimates of the proportion of birds flying at risk height should reflect the range of turbine heights which potentially may be used. Survey methods should be designed to ensure that data are available to inform all potential turbine options. Guidance on the extent to which the details of a scheme may be kept flexible during the environmental assessment process is published by the Infrastructure Planning Commission (2011)<sup>vii</sup>.
30. The central estimate of the proportion of birds flying at risk height should be based on a straightforward analysis of flight height survey data, without any 'margin of uncertainty' added to the risk height range. In addition, alternative +/- estimates should also be presented, reflecting the possibility of a higher or lower proportion of birds flying at risk height. Confidence intervals on flight height data should be used where these are available from the survey information. Otherwise, a realistic view should be taken of the potential for mis-estimation and error in flight height observations by field observers. Confidence intervals should be aimed at around 95% confidence that the true result lies within that range. In some circumstances, this may be no more than an expert view based on an understanding of the limitations of the survey techniques.
31. **For the purpose of estimating collision risk, the ES should state**
  - **the proportion of birds estimated to be flying within the risk height band – ie between the lowest point of the rotors and the highest point of the rotors – based on survey information at the site;**
  - **any flight height distribution derived from combining wider survey data for the species in question, and the proportion of birds thereby assumed to fly at a height exposed to collision risk;**
  - **which of the above is used in the collision risk estimate, and why.**

#### **Daylight hours and nocturnal activity**

32. For obvious reasons, most bird survey is undertaken by day, and it is generally assumed that such sampled levels of flight activity persist throughout daylight hours. Daylight hours depend both on time of year and on latitude. Forsythe et al (1995)<sup>viii</sup> provide a ready reckoner for daylight hours which is reproduced in Sheet 7 (Daylight and night hours) of the attached spreadsheet. Input of the latitude of the site in Sheet 1 (Input data) triggers the calculations in Sheet 7 (Daylight and night hours) which in turn populates Sheet 2 (Overall collision risk) with the appropriate number of daylight and night hours in each month.
33. There is considerable uncertainty about levels of bird flight activity by night. Garthe and Hüppop (2004)<sup>ix</sup> offer an expert view on levels of nocturnal flight activity for a range of marine bird species, expressed in terms of a 1-5 ranking of the likely level of nocturnal activity in comparison with observed levels of daytime activity. A rating of 1 represents hardly any flight activity at night, and 5 much flight activity at night. King et al (2009) (Appendix 7)<sup>x</sup> provides a

more comprehensive table with rankings on a similar expert basis for a wider range of seabirds.

34. Figures used in the collision model should take both day and night flights into account. Where there is no night-time survey data available, or other records of nocturnal activity, for the species in question, (or for other sites if not at this site), it should be assumed that the Garthe and Hüppop/ King et al 1-5 rankings apply. These rankings should then be translated to levels of activity  $f_{\text{night}}$  which are respectively 0%, 25%, 50%, 75% and 100% of daytime activity. These percentages are a simple way of quantifying the rankings for use in collision modelling, and they may to some extent be precautionary. For some species, there are no such expert rankings available. Levels of activity may vary from season to season, and activity at sea may in any case differ from the levels of activity in breeding colonies for which the rankings have been formulated. Some species are particularly active during dawn and dusk or extended twilight periods, or in locations where there is ambient windfarm lighting. When expressing the output of the collision risk assessment, the uncertainty surrounding flight activity should reflect the degree of confidence (or lack of confidence) in the flight activity information.
35. **Flight activity estimates should allow both for daytime and night-time activity. Daytime activity should be based on field survey. Night-time flight activity should be based if possible on night-time survey; if not on expert assessment of likely levels of nocturnal activity.**

#### STAGE B - ESTIMATING NUMBER OF BIRD FLIGHTS THROUGH ROTORS

36. In the basic model, this stage is straightforward, but one which often causes some difficulty. It can be addressed in the following steps:
- (i) Start with the observed bird density on an area basis, expressed per unit area,  $D_A$ . Convert if needed to units of birds/ $\text{m}^2$ . If the survey data is expressed in birds/ $\text{km}^2$  then divide by  $10^6$ .
  - (ii) Multiply by the proportion  $Q_{2R}$  of birds flying at risk height to get only those birds at risk in a column of air of unit area base and  $2R$  high (ie from bottom to top of the rotor) – see Figure 4.

**Fig 4: Birds flying at risk height**

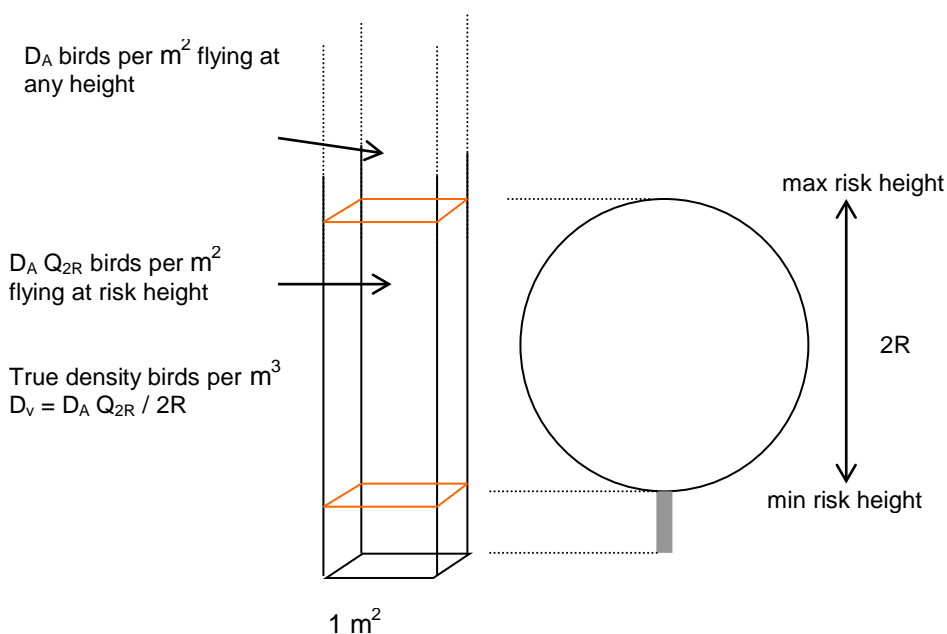

- (iii) Calculate the true bird density per unit volume  $D_V = (D_A Q_{2R}) / 2R$ , expressed in birds per  $m^3$  (birds per cubic metre).
- (iv) Now calculate the flux of birds through a rotor within an airspace of true bird density  $D_V$ , noting that we are making the simplifying assumptions that all birds are flying perpendicular to the rotor, and that they are all flying with a single flight speed  $v$ . Also, the rotor may be assumed to face the wind at all times. It is also, for simplicity, assumed that there are equal numbers of birds flying upwind as are flying downwind, which is important as the collision risk when flying upwind is greater than for downwind flight<sup>2</sup>.

Consider the area of the rotor  $A = \pi R^2$ . If the birds fly at speed  $v$  m/sec, then within one second, all birds within a distance  $v$  on one side and flying towards the rotor will pass through the area  $A$ . At any one time, half the birds will be travelling upwind and half downwind. Thus, referring to Figure 5, at any time there will be  $\frac{1}{2} D_V A v$  birds flying downwind towards the rotor and, on the other side of the rotor,  $\frac{1}{2} D_V A v$  birds flying upwind towards the rotor.

**Fig 5: Bird flux due to bird density**

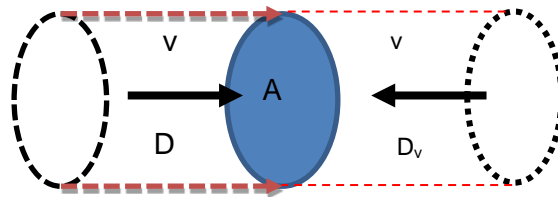

$$\begin{aligned} \text{Thus bird flux } F &= \frac{1}{2} D_V (\pi R^2) v \text{ upwind plus } \frac{1}{2} D_V (\pi R^2) v \text{ downwind} \\ &= v D_V (\pi R^2) \text{ in total} = v (D_A / 2R) (\pi R^2) Q_{2R} \quad \dots (1) \end{aligned}$$

This is expressed in birds/second passing through the rotor.

- (v) Now multiply by the appropriate number of seconds during which the birds are potentially active – usually the daylight hours in the month  $t_{\text{day}}$  plus an allowance if appropriate for nocturnal activity  $f t_{\text{night}}$ , multiplied by 3600 to convert to seconds.
- (vi) Multiply by the number  $T$  of turbines. Each turbine in a windfarm, if it is surrounded by an airspace with the same bird density, and if all turbines are of the same size, will experience the same number of bird transits and will therefore contribute the same collision risk to the overall total. If the windfarm includes turbines of different sizes, or zones of differing bird densities, then the calculation should be broken down into subgroups of wind turbines where turbine size and bird density is constant within each subgroup.
37. The result is an estimate of the total number of bird transits through rotors of the wind farm in the specified period. In the spreadsheet provided, the entry for 'bird transits' calculates the total number of bird transits for each month, taking account of the proportions of flights deemed to be upwind and downwind. It calculates the result on the basis of the values entered for  $D_A$ ,  $Q_{2R}$ ,  $R$ ,  $v$ ,  $T$ , time for which birds are active, ie the calculation includes all of stages (i) to (vi) above.

<sup>2</sup> If the collision model is applied specifically to migration flights, or to flights in adverse weather conditions, it may be that a majority of flights will be downwind, in which case the proportions of bird flux should be altered as appropriate from the  $\frac{1}{2}$  upwind and  $\frac{1}{2}$  downwind assumption made here.

Total number of bird transits =

$$\underbrace{v (D_A / 2R) (T \pi R^2) (t_{\text{day}} + f_{\text{night}} t_{\text{night}})}_{\text{flux factor}} \times \underbrace{Q_{2R}}_{\text{proportion at risk height}} \dots (2)$$

38. A key output within the collision risk assessment should be a clear statement of the potential number of bird transits per month, and per year, through the windfarm turbines, assuming birds take no avoiding action. The collision risk is directly proportional to the potential number of bird transits.

<b>Box 1: Converting from bird density to rotor transits (basic model)</b>			
<u>Worked example:</u>			
v	Bird flight speed	10.5	m/sec
D <sub>A</sub>	Bird density per unit area 50% upwind, 50% downwind	0.1128 = 0.1128x10 <sup>-6</sup>	birds/km <sup>2</sup> birds/ m <sup>2</sup>
R	Rotor radius	63	m (metres)
T	Number of turbines	150	
TπR <sup>2</sup>	Frontal area of all rotors	1870345	m <sup>2</sup>
t	Hours active in June (t <sub>day</sub> + f <sub>night</sub> t <sub>night</sub> )	480 = 1.728x10 <sup>6</sup>	hours seconds
F	Flux factor v (D <sub>A</sub> / 2R) (T πR <sup>2</sup> ) t	30380	
Q <sub>2R</sub>	Proportion flying at risk height	28.1%	
	Total bird transits through turbines in June	8537	50% upwind, 50% downwind

## STAGE C – PROBABILITY OF COLLISION FOR A SINGLE ROTOR TRANSIT

39. This stage begins with the model described in the earlier Band (2000) and Band et al (2007) papers which uses information on the size and speed of the turbines, and physical details on the size and speed of the bird, to compute the risk of collision for a bird flying through a rotating rotor. Annex 3 is an extract from Band (2000) outlining the core of the model and its derivation.
40. A bird is simplified in shape to a flying cross with length, wingspan, and speed, and always flying perpendicularly towards the rotor. A bird may be 'gliding' ie with the arms of the cross fixed, or 'flapping' ie with the arms of the cross flapping so as to occupy a space similar to that of a spinning top, with the length of the bird being the axis of spin. 'Gliding' flight has a marginally lower collision risk than 'flapping' flight – notably for passage at points level with the rotor hub, where the wings lie parallel with potentially colliding blades. However the difference is rarely sufficient to warrant detailed consideration of different bird behaviours; the flight type used should be that which best typifies most flights for the species in question.
41. Rotor blades are assumed to be laminar (ie with zero blade thickness) but they have length, a chord width which varies along the length of the blade tapering towards the tip, and a pitch angle (the angle between the blade and the rotor plane) which also varies along the length of the blade. Due to commercial sensitivities by blade manufacturers, some of this detailed information may not be readily available for each make/model of blade and hence generic information may have to be used.
42. With these simplifications, the model calculates the risk of actual collision between the bird and the rotor blades. Such a model has a number of important limitations:
- Stationary infrastructure - it is assumed that birds can avoid stationary infrastructure, so no account is taken of the turbine towers, nor the blades when stationary; While this may be a valid assumption in clear daylight conditions it may not be wholly true at night or in conditions of poor visibility. Onshore, for example, there are records of gamebird species colliding with turbine towers. In this respect, the model may underestimate collision risk.
  - Turbulence - no account is taken of the effects on a bird's flight of turbulence in the wake of a blade. Observers have seen birds 'knocked out of the sky' by turbulence, and there is potential for this to increase mortality through disorientation or impact with the sea surface. The model only takes account of the potential for physical contact between the bird and the turbine blades. In this respect, the model may underestimate collision risk.
  - Slipstream - however, it is also the case that the model does not take account of any 'slipstream' effects whereby the air rushing over the surface of a blade may carry a bird clear of the blade when otherwise it was on a collision course. In this respect, the model may over-estimate collision risk.
  - Bird shape - real birds are larger than represented by a flying cross, though a cross should represent the main extremities. In this respect, the model may underestimate collision risk.
  - Flight height distribution - the basic collision model evaluates the probability of a bird colliding if it passes at random at any point through the rotor disk on a flight path perpendicular to the rotor plane. In practice, the points of passage of seabirds through the rotor are not distributed uniformly across the rotor. Survey data for seabirds has made clear that typical flight heights for many species are relatively low, such that much of the bird flux through a rotor, and the associated collision risk, will relate to the lower parts of the rotor plane. Since it averages risk over the entire rotor including higher-risk areas close to the hub, the basic model will overestimate the collision risk for seabirds whose flight passages are more concentrated towards the lower part of the rotor plane. Where



data are available on the distribution of bird density with height, an extended calculation may be undertaken which takes account of this variation with height. This extended model is described following stage D, in paragraphs 61-75.

- Perpendicular approach assumption – as outlined in Annex 1, the model used assumes that the collision probability for oblique angles of approach is the same as for perpendicular approach. In fact, some increase in collision risk should be expected, which, taking account of both upwind and downwind flight, may be of order 10% for large birds. In this respect, the model may underestimate collision risk.

43. The model uses a probability  $p$  of collision for a bird flying through a rotor, at a point in the rotor plane defined by coordinates  $r, \varphi$  :

$$p(r, \varphi) = ( b\Omega/2\pi v ) [ | \pm c \sin\gamma + \alpha c \cos\gamma | + \max ( L, W\alpha F ) ] \quad \dots \quad (3)$$

where

- $r$  = radius of point of passage of bird
- $\varphi$  = angle within rotor plane (relative to vertical) of point of passage of bird  
ie  $\varphi=0$  is top,  $\varphi=\pi$  is bottom, etc
- $b$  = number of blades in rotor
- $\Omega$  = angular velocity of rotor (radians/sec)
- $c$  = chord width of blade
- $\gamma$  = pitch angle of blade
- $R$  = outer rotor radius
- $L$  = length of bird
- $W$  = wingspan of bird
- $\beta$  = aspect ratio of bird ie  $L / W$
- $v$  = velocity of bird through rotor
- $\alpha$  =  $v/r\Omega$
- $F$  = 1 for a bird with flapping wings (no dependence on  $\varphi$ );  $F = \cos \varphi$  for a gliding bird

This probability is then averaged, by integrating over the entire rotor area, to yield the average collision risk for a bird making a single flight through the rotor at any point through the rotor.

44. By way of explanation, there are three terms in equation (3) within the square brackets.

- The first  $[ c \sin\gamma ]$  relates to the time taken for the bird to clear the depth of the blade, which increases with pitch  $\gamma$ .
- The second  $[ \alpha c \cos\gamma ]$  relates to the probability of the bird striking the front face of the blades. Note that the appearance of  $\alpha$  cancels any dependence of this term on rotor angular velocity  $\Omega$  and bird speed  $v$ .
- The final term  $[ \text{the greater of } L, \text{ or } W\alpha F ]$  relates to the time taken for the full length and wingspan of the bird to clear the sweep of the rotors, for which the geometry depends on the relative speed of bird and blade. Where the bird's aspect ratio  $\beta > \alpha$ , the bird length is the limiting parameter. However if  $\beta < \alpha$  the wingspan is the limiting parameter. For a flapping bird,  $p( r )$  not dependent on  $\varphi$  and  $F$  is set to 1. For a gliding bird, the effective wingspan depends on  $\varphi$ , reducing to zero at  $\varphi = \pi/2$  or  $3\pi/2$  where the wings lie parallel to the rotor blade; thus  $F = \cos \varphi$ .

45. Because of the geometry of the blades in relation to the flight direction, the collision risk for upwind flight is higher than for downwind, even if the bird's flight speed  $v$  relative to the ground is taken to be the same. This is expressed in the alternate sign in the first term, which is + for upwind flight, - for downwind. In practice, birds will fly more slowly in upwind flight

than downwind, further widening the difference in risk between upwind and downwind flight (see paragraph 51). If both upwind and downwind flights are equally likely, it is appropriate to take an average of upwind and downwind collision probabilities.

46. The basic model assumes that bird flights may occur with equal probability at any point through the rotor disc. Having ascertained the collision risk  $p(r, \phi)$  at different points  $r, \phi$  of the rotor, the basic model then calculates an average of  $p(r, \phi)$  over the entire area of the rotor disc, firstly summing over  $\phi$ , then summing (integrating) over successive concentric rings, taking account of the area of each ring which increases with radius (= ring circumference  $2\pi r$  times thickness of ring  $dr$ ). Finally this sum is divided by the overall disk area to get the average collision probability:

$$p_{\text{average}} = \int_0^R p(r) (2\pi r) dr / \int_0^R (2\pi r) dr = \int_0^R p(r) (2\pi r) dr / \pi R^2 = 2 \int_0^1 p(r) (r/R) d(r/R) \dots(4)$$

47. Sheet 3 (Single transit collision risk) of the spreadsheet accompanying this guidance provides a collision risk calculator for a single passage through the rotor, evaluating  $p(r)$  for a series of twenty radii from  $r/R=0.05$  to  $r/R=1$ , and undertaking the above integration numerically to evaluate  $p_{\text{average}}$ , the average collision risk for a passage at any point across the rotor. This is essentially the same as the spreadsheet referred to in Band (2000)<sup>i</sup> but with refinements to the numerical integration<sup>xi</sup>.

### Wind turbine speed

48. Wind turbines currently available are designed to operate at a range of speeds. Typically they do not operate below a cut-in speed (usually between 3 and 4 m/sec), then increase in speed with wind speed up to an operating wind speed (which may be around 12 m/sec). Thereafter, they maintain a constant operating speed by altering the pitch of the blades until, in extreme conditions, the turbine is shut down for safety.
49. **Collision risk should be evaluated using the turbine rotational speed for an operating turbine. Where turbines operate with a range of rotational speeds, the calculation should be done using a mean operational turbine speed. The mean used should be a mean over time, using an analysis of wind data to enable the likely frequency distribution of turbine speeds to be determined.** Allowance is made elsewhere in the calculation (at Stage D) for the proportion of time that a turbine is non-operational, either because of low wind speeds or for maintenance. The mean turbine speed should thus be a mean over operational time only, not including times when the turbine is idling or stationary. Within the typical range of operating turbine speeds, collision risk varies almost linearly with turbine speed, so that use of a mean turbine speed is adequate in order to yield a mean collision risk – see Fig 6 for a turbine with a maximum operating speed of 12.1rpm. If a frequency distribution of turbine speeds is not available, then collision risk may be evaluated using the maximum operating turbine speed, but acknowledging that this will result in a collision risk which is an upper bound rather than a mean.

**Fig 6: No-avoidance collision risk as a function of turbine speed for a 5MW turbine and bird (gannet)**

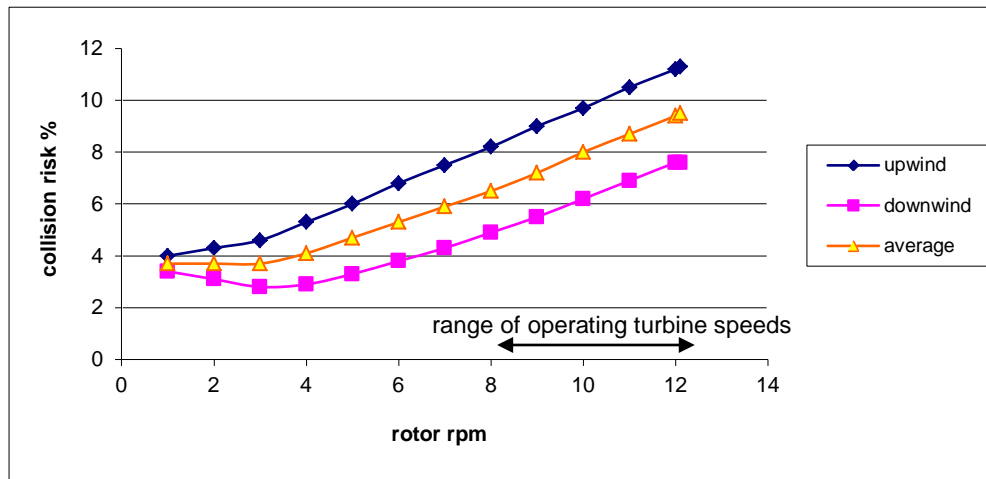

### Accuracy of model

50. Having regard for the various simplifications in the model, and the potential sources of under- and over-estimation described above, it is judged that this stage of the model, calculation of no-avoidance collision risk for a single transit, should be regarded as indicative of collision probability within around  $\pm 20\%$ . If the flight height distribution is strongly skewed towards the low edge of the rotor, the basic model is likely to overestimate collision risk by more than this margin, while there should be no such overestimation if the extended model is used. These uncertainties are in addition to any uncertainty due to variance in flight activity and other input data (Stage A), or due to uncertainties in avoidance rates (Stage E).

### Possible refinements

51. The spreadsheets are set up so that the average collision risk from the 'Single transit collision risk' calculation is copied over to the 'Overall Collision Risk' sheet and used, as described in the next section, to calculate projected collision mortality. However two refinements may be made at this stage.

- The 'Single transit collision risk' sheet assumes that the bird speed for both upwind and downwind flight is the same, derived from standard references. In fact, it is likely that ground speed downwind will be greater, and ground speed upwind, less than this value. If good data are available, either from field survey or from the literature, to support the use of different up/downwind ground speeds, then this spreadsheet may be run once for each, taking the average of the respective 'upwind' and 'downwind' outputs to copy over to the 'Overall Collision Risk' sheet.
- In taking an average for upwind and downwind flights, the 'Single transit collision risk' sheet uses the relative proportion of upwind and downwind flights to weight the respective collision probabilities. By default the proportion should be set to 50% upwind (and thus 50% downwind). However there are some circumstances, eg migration flights, in which downwind flights may dominate, though flight directions are often far from regular. If field data support the use of differing proportions of upwind and downwind flight, then the proportions may be changed by altering the 'Proportion of flights upwind' field in the Input Data sheet.

## STAGE D – MULTIPLYING TO YIELD EXPECTED COLLISIONS PER YEAR

### Basic model – assuming uniform flight density

52. If the basic model is used, multiplying by the number of bird flights through the rotor is nearly trivial. Stage A has estimated the level of flight activity at potential risk; Stage B has estimated the likely number of flights through rotors across the windfarm; Stage C has calculated the risk of collision for a single bird transit through a rotor. In the present stage, Stage D, these are multiplied together to yield an estimate of total potential collision risk, including a factor to allow for the proportion of time that the wind turbines are operational (before considering avoidance behaviour, which is stage E).

$$\text{Expected collisions} = \underbrace{\text{Flux factor} \times Q_{2R}}_{\text{No of transits}} \times \underbrace{\text{Average probability of collision}}_{\text{Single transit collision risk}} \times \underbrace{Q_{op}}_{\text{Proportion of time operating}} \dots(5)$$

### Units

53. Whichever model is used, there is a need for care with units. In the spreadsheet, flight activity becomes expressed as rotor transits per month and hence the collision risk is in predicted collisions per month.

### Non-operational time

54. Turbines do not operate all of the time. Typically a turbine may be at rest or idling for a considerable proportion of time, eg 20%, because the wind is too weak to generate power, or (exceptionally) because the turbines have been closed down to avoid damage in high wind. There is also a requirement for some downtime for maintenance. This non-operational time is accounted for in equation (5) by the factor  $Q_{op}$  representing the proportion of time the turbine is operational. If data is available, this factor may be stated on a monthly basis to reflect the different proportions of non-operational time at different times of year – for example reflecting differing wind conditions across the year and increased access for maintenance during the summer.

### Large turbine arrays

55. The model assumes that risks are additive, ie that a windfarm with 200 turbines will have 200 times the risk of a single turbine. Where a bird passes successively through two or more turbines, it is exposed to the same risk for each rotor transit. While it is possible that a bird encountering its first turbine may deviate so as to pursue a safer course through (or above or around) the windfarm, this is avoidance behaviour and therefore properly taken into account at Stage E rather than here. Stages A - D simply work out the consequences of birds taking no avoiding action<sup>3</sup>. Thus, if two turbines 'overlap' in the sense that the bird passes through both turbines in a single passage, no allowance is made for that overlap, the collision risk is the sum of the risk from each rotor passage.

56. More strictly, for large windfarms where the overall probability of a bird colliding is relatively high, it may be appropriate to take account of the fact that a declining proportion of the birds will survive passage through early rows of turbines and will thus be exposed to collision risk in later rows. This adjustment is only likely to be of any significance for large arrays of turbines.

<sup>3</sup> This position was somewhat confused by a reference in Band et al (2007) to making a 50% allowance for overlapping turbines. It is now preferred that any amendment to collision risk resulting from avoidance behaviour should be built into the avoidance rate applied at the end of the calculation.

57. Annex 4 sets out how such a correction may be made for a windfarm with approximately  $n$  rows of turbines. Very often the layout of a windfarm is not known at the time of collision risk assessment, so an exact value for  $n$  is not known; and in any case the collision risk has to account for birds entering the windfarm from all directions. Sometimes the layout of the windfarm is irregular, lacking in clearly defined rows; but the principle remains that a declining number of birds will be exposed to collision risk if a proportion have already been killed by collision with earlier rotors as they pass through the windfarm. A reasonable and simple approximation is to use  $n = \sqrt{T}$  ie the square root of the total number of turbines.

58. If the probability of collision for a single bird passage through the windfarm is  $C$ , based on the purely additive approach elsewhere in this guidance, then it may be adjusted to allow for depletion of bird density in later rows of the windfarm by multiplying by a 'Large array correction factor'

$$C_{LA} / C = 1 - ((n-1)/2n) C + ((n-1)(n-2) / (6 n^2)) C^2 \dots \dots(6)$$

plus further negligible terms of powers of  $C$

59. If realistic avoidance rates have been taken into account in the collision model, such 'large array corrections' are typically small and can be ignored; typically it is only worth making corrections for values of  $C > 0.1$ .

60. See Annex 4 for a derivation of this 'large array factor', and a worked example. Sheet 8 – 'Large array correction' in the spreadsheet provides a calculator for this factor. The spreadsheet applies this correction factor to the output of Sheet 2 – 'Overall collision risk' by multiplying each projected collision rate, for each of the various avoidance rates, by the correction factor. In most circumstances it will be evident that the difference is minimal.

## EXTENDED APPROACH TAKING ACCOUNT OF FLIGHT HEIGHTS

### Effects of taking flight height into account

61. Seabirds tend to fly at relatively low altitude over the sea surface. If the flight height distribution is skewed towards low heights in this way, there are three ways in which taking account of flight height is important to the calculation of collision risk:

- (i) The proportion  $Q_{2R}$  of birds flying at risk height will decrease with the height of the rotor above the sea surface. This is accounted for in the basic model if the parameter  $Q_{2R}$  is adjusted, but the way in which  $Q_{2R}$  changes with height can only be known if a flight height distribution for the species in question is available.
- (ii) If most of the birds flying at risk height (ie above the minimum level of the rotor) do so at a level not far above the bottom edge of the rotor, the probability of passing through the rotor disc is relatively small, simply because the rotor circle occupies less width at that level than, for example, at the midpoint of its diameter. Therefore the expected number of rotor transits is reduced. For some species the reduction may be 50% or more, reducing the collision risk in proportion.
- (iii) Finally, if the birds flying through the rotor do so close to the extremity of the blades, the single-transit probability of collision there is rather less than for passages closer to the hub. This is a smaller effect, but may typically account for a reduction of around 10%.

For these reasons, if the data is adequate to support an extended analysis taking account of flight heights, it is well worth doing so.

## When to use generic flight height distribution data

62. Normally, the bird survey data available for a particular site is insufficient to provide a full flight height distribution. However it may provide some insight into typical flight heights at the site, and it should provide information on the proportion of birds flying at risk height ie above minimum rotor height. The Crown Estate SOSS group has commissioned a compilation of flight height data from windfarm sites across the UK (Cook et al 2012<sup>iii</sup>). That paper contains generic flight height distributions for a number of seabird species.
63. Caution is needed in deploying this generic data. It is entirely possible that the ecological circumstances of a particular site differ from those in the sites used to generate the generic data, and hence bird behaviours and flight heights may not be well represented by the generic data. Before using generic data, consideration should be given to whether
- is the site survey data compatible with the generic data? Does it indicate that the generic data reasonably represents the observations at this site?
  - are there particular ecological circumstances which might be expected to lead to non-standard behaviour, eg proximity to breeding sites?
64. A collision risk assessment for a specific site should not be based solely on the use of generic data. Where generic data is used, it is recommended that the collision risk for three different options is stated:
- Option(i) - using the basic model, ie assuming that a uniform distribution of flight heights between lowest and highest levels of the rotors; and using the proportion of birds at risk height as derived from site survey.
  - Option (ii) - again using the basic model, but using the proportion of birds at risk height as derived from the generic flight height information.
  - Option (iii) - using the extended model, using the generic flight height information.

The spreadsheet supporting this guidance provides for the calculation of all three options. If site survey information is sufficient to generate a flight height distribution, this should be used as an Option (iv) as well.

Supporting text should then discuss and justify which of the options is most likely to characterise the collision risks at this site.

## The hard stuff (ie maths)

65. This section extends the basic model, and the calculations in Stages B-D, to enable the distribution of flight heights to be taken into account. The basic model calculates the number of transits through rotors, then multiplies these by the average collision probability for a single transit (see equation (5) in paragraph 52):

No of collisions = number of transits x probability of collision

The extended approach is underlain by this same equation. However, in this extended model, both bird flux and the probability of collision may vary over the area of the disc, such that their product must be summed over the whole area of the rotor disc.

66. The bird flux through an element of rotor area  $\delta A$  is

$$v D_v \delta A$$

as in equation (1) in paragraph 36, but applying it to a small area  $\delta A$  rather than the full rotor area  $A$ . As before there is a need to consider the proportions of flights upwind and downwind; we shall assume (for example) 50% upwind, 50% downwind.

In this extended model,  $D_v$  may vary with height  $Y$  – this is the flight height distribution  $D_v(Y)$  in birds/m<sup>3</sup> at height  $Y$  metres.

67. The collision risk for a single transit through this element  $\delta A$  is  $p(X,Y)$ , which is the same as  $p(r,\varphi)$  except that X-Y coordinates, with origin at the rotor hub, are used to reference the point of transit instead of r- $\varphi$  coordinates; the relationship between these two coordinate sets are

$$X = r \sin \varphi, \quad Y = r \cos \varphi \quad \text{or conversely} \quad r = \sqrt{X^2+Y^2}, \quad \varphi = \tan^{-1}(X/Y)$$

**Fig 7: Relationship between r,  $\varphi$  and X,Y coordinates**

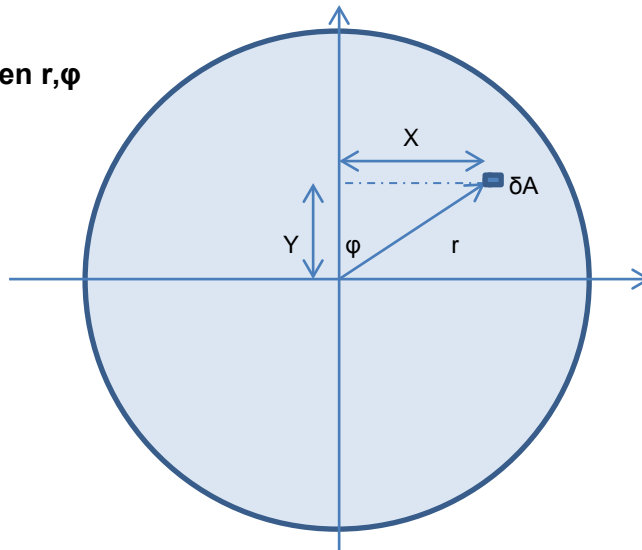

The collision rate through this small element  $\delta A$  (take it as a small rectangle of width  $dX$  and height  $dY$ ) is thus

$$v D_v(Y) p(X,Y) dX dY$$

The total collision rate for flights through the whole rotor disc is then obtained by integrating this over the whole area of the disc:

$$\text{Collision rate} = v \int_{\text{Min rotor height}}^{\text{Max rotor height}} D_v(Y) \int_{-\sqrt{R^2-Y^2}}^{+\sqrt{R^2-Y^2}} p(X,Y) dX dY \quad \dots (7)$$

The limits  $\pm\sqrt{R^2-Y^2}$  to the integration over X define the outer limits of the rotor circle, and the limits to the integration over Y are the minimum and maximum rotor heights respectively.

68. With this approach, it is not easy to think in terms of there being a defined bird flux, and an average probability of collision, which are then multiplied. The bird flight density varies with height Y, the breadth of the circle (and therefore the number of birds flying through the circle) varies with height Y, and the collision risk too depends on height Y, as it varies with both r and  $\varphi$ . Hence all these factors are expressed and multiplied within the integral, and the integration yields the collision rate.

69. As with the basic model, to translate this into collisions per month in the windfarm, this must be multiplied by the number of seconds the birds are active, and the number of turbines, and by the factor making allowance for non-operational time.

70. For computational purposes, it is best to translate the factors into dimensionless units, within which the rotor has a radius of 1, by using the parameters  $x = X/R$ ,  $y=Y/R$ ; and using a dimensionless flight height distribution  $d(y) = R D_v(Y)/D_A$ . Using these factors, and adding in the other factors (number of turbines, etc), equation (6) becomes

$$\text{Collisions} = v D_A R \int_{-1}^{+1} d(y) p(x,y) dx dy \times \text{No of turbines } T \times \text{Time active } t \times \text{Proportion of time operational } Q_{op} \quad \dots (8)$$

$$= \underbrace{v (D_A/2R) T \pi R^2 t}_{\text{Flux factor}} \times \underbrace{\left( \frac{2}{\pi} \int_{-1}^{+1} d(y) p(x,y) dx dy \right)}_{\text{Collision integral}} \times \underbrace{Q_{op}}_{\text{Proportion of time operational}} \quad \dots (9)$$

It is written in this way for comparability with equation 5 above; the ‘flux factor’ and  $Q_{op}$  are the same as used in the basic model. The ‘Collision integral’ is a dimensionless quantity. If we apply this to the earlier scenario in which a proportion  $Q_{2R}$  of birds fly at risk height, and are distributed uniformly at all heights within that zone, we then have  $d(y) = Q_{2R}/2$ , a constant. The Collision integral is then  $Q_{2R}$  times the average of  $p(x,y)$  over the rotor disc; in that case equation (9) reproduces equation (5).

71. The total bird flux passing through the rotors is similar to equation 9 but with  $p(x,y)$  set to 1, ie

$$\text{Flux} = \underbrace{v (D_A/2R) T \pi R^2 t}_{\text{Flux factor}} \times \underbrace{\left( \frac{2}{\pi} \int_{-1}^{+1} d(y) dx dy \right)}_{\text{Flux integral}} \times \underbrace{Q_{op}}_{\text{Proportion of time operational}} \quad (10)$$

72. The average collision probability is just the ratio Collisions /Flux. However it should be noted that this ‘average probability’ is conditioned both by the shape of the circle (more flux at greater height) and by the skewed distribution of flights (ie more flux at lower height), so it is not a very meaningful parameter.

73. Note that the factor  $Q_{2R}$  does not appear explicitly in the above equations, as the proportion of birds flying at various levels is included within the distributional data  $d(y)$ . However, for comparison with the basic model, a value  $Q'_{2R}$  is readily calculated from the distribution data, as

$$\int_{-1}^{+1} d(y) dy = Q'_{2R}$$

The symbol  $Q'_{2R}$  is used to differentiate this calculated figure from the figure for  $Q_{2R}$  input earlier based on bird survey data.

Annex 5 provides a more detailed derivation of these equations.

### The easy stuff (how to do the calculation)

74. Calculating a collision estimate using equation (9). and the number of transits through rotors using equation (10), can be done simply using Sheet 4 ‘Extended model’ which computes both the Collision integral and the Flux integral, if an appropriate flight height distribution is input. The flux factor remains as calculated in Stage B for the basic model, and  $Q_{op}$ , the proportion of time turbines are operational, as in Stage E.

- (i) Start, as in Stage B of the basic model, with the observed bird density on an area basis, expressed per unit area,  $D_A$ . Convert if needed to units of birds/ km<sup>2</sup>; the spreadsheet



divides this by  $10^6$  so as to work in birds/m<sup>2</sup>. As with the basic model, multiply by the total cross-sectional area of the rotors  $\pi R^2$ , and the number of seconds  $t$  during which birds are active, to get the Flux factor. There is no need however to deploy  $Q_{2R}$ .

- (ii) Data on the flight height distribution must be available as a table showing the relative frequency of bird flights at different heights. This data should be normalised, that is the sum of all the relative frequencies across all heights should be 1. Relative frequency is  $D_v(Y) / D_A$ , and the sum of  $D_v(Y)$  across all heights is just  $D_A$ , the total bird density per km<sup>2</sup>, so the sum of all relative frequencies is 1. Frequency is in units of 'per metre of height'.
- (iii) Sheet 5 of the spreadsheet 'Flightheights' contains generic data from Cook et al<sup>iii</sup> for a number of species. These give flight height relative frequencies at 1m intervals; only the data up to 150m height is shown in the spreadsheet. Columns A and B are the 'master data' ie these columns contain the data which are used in the calculations of Sheet 3. To use a new data table (eg for other species, copy the appropriate flight height column for this species and paste the column into column B (note, don't cut and paste, just copy, so as to leave intact a copy of the data outwith the master columns. The entire column should be copied and pasted, as it includes the name of the species and the number of points in the table, as well as the table of frequencies itself.
- (iv) Normally, the hubheight of wind turbines is measured from Highest Astronomical Tide (HAT), to help ensure navigational clearance requirements are satisfied. However, bird flight heights are measured relative to sea level, which may be 2-3 metres or more lower. Mean sea level ( $Z_0$ ) and HAT are normally stated relative to Chart Datum (CD). The calculation allows for a tidal offset to be added to the hubheight, to allow for this additional height above mean sea level. The tidal offset should be entered in the Input Data sheet. This offset can make a substantive difference to the calculated collision risk, reducing the estimate of risk by 25-30% for some species.
- (v) Sheet 4 'Extended model' then does the necessary work in calculating the Collision and Flux integrals. The sheet undertakes a numeric integration of  $p(x,y)$ , first across  $x$  for each horizontal chord of the rotor, and secondly across all heights  $y$ , factoring in the flight distribution  $d(y)$ .
- (vi) Following equation (9), multiply the Collision integral by the Flux factor and by the proportion of time  $Q_{op}$  for which the turbines are operational, to get the expected collisions assuming no avoidance. Sheet 2 'Overall collision risk' draws on the Collision integral calculated in Sheet 4, and does this multiplication. It also draws on the Flux integral in Sheet 4, to provide a view on the total number of rotor transits in each month. These calculations are presented as 'Option 3'
- (vii) In this extended model, the distribution of bird flights with height already includes the information on the proportion flying at risk height. It is valuable nonetheless to evaluate  $Q'_{2R}$  from the flight height data and check that it is consistent with survey findings and other sources of data. Sheet 4 shows the value of  $Q'_{2R}$  derived in this way directly from the flight height distribution, using the formula

$$Q'_{2R} = \int_{-1}^{+1} d(y) dy$$

75. Adding a tidal offset as at stage (iv) takes account of the height of the rotors above mean sea level, but not of the variation of the tides. If the distribution of bird flight heights relative to the sea surface is independent of the level of the tide, then at times of high tide there will be an increased bird density at rotor level, and reduced at times of low tide. As the flight height distribution is non-linear with height, these two effects do not balance out. The 'tidal asymmetry correction' factor is generally small and may be ignored, but a method of calculating it is nonetheless provided, in Annex 7, for use at sites with a particularly large tidal range (eg > 5metres).

## STAGE E – AVOIDANCE AND ATTRACTION

### Avoidance

76. The preceding stages of the model assume that birds take no avoiding action whatsoever in response to wind turbines. In reality, birds mostly do take effective avoiding action so as to avoid collision with wind turbines. Birds may avoid the area of the windfarm altogether, or they may use more indirect flight routes to bypass the windfarm – referred to as ‘macro’ or ‘far-field’ avoidance or ‘displacement’. Alternatively, birds may continue to fly within or close to the windfarm, but exhibiting ‘micro’ or ‘near-field’ or ‘behavioural’ avoidance in which birds choose routes which pass between rotors; or fly higher or lower to avoid the rotors; or take emergency action in-flight to escape an approaching blade.
77. Monitoring of windfarms onshore is generating some useful information on levels of avoidance of some land-based bird species. Some of that data derives from collision monitoring, based on regular site scans for bird corpses, and some of it from observations of habitat use in the vicinity of windfarms. For many bird species, avoidance rates of 98% or higher have been observed, implying that the collision risk is less than 2% of that calculated from stages A-D alone. **Avoidance is included in the collision risk model simply by multiplying the before-avoidance collision estimate by (1 - A) where A is the appropriate overall avoidance rate (see Scottish Natural Heritage 2010<sup>xii</sup> for a review).**
78. In general the information for onshore species is not sufficient to discriminate in a quantitative way between macro avoidance (ie displacement or far-field avoidance) and micro (near-field) avoidance, though some Dutch studies are yielding useful data. Offshore, a number of studies have examined macro and micro avoidance behaviour for some seabirds (see Cook et al (2012)<sup>iii</sup>). As monitoring data builds up from constructed offshore windfarms, it may be possible to make more definitive predictions than at present on rates of both macro and micro avoidance. The overall avoidance rate  $A_{\text{overall}}$  is simply related to macro and micro avoidance rates:

$$(1 - A_{\text{overall}}) = (1 - A_{\text{macro}}) \times (1 - A_{\text{micro}})$$

To obtain an overall avoidance rate in this way, information is needed on both macro and micro avoidance rates, each of which will be less on its own than the overall avoidance rate. In particular, if information on likely displacement is used to conclude that a proportion of birds will not use the windfarm site, that is in effect an application of the  $(1 - A_{\text{macro}})$  factor. The avoidance rate then applied to those birds not displaced would then have to be a micro-avoidance rate  $A_{\text{micro}}$ , derived from monitoring observations solely of birds actually flying through windfarms. A micro-avoidance rate will be considerably lower than a rate for overall avoidance which includes displacement effects.

79. Where detailed information on macro and micro avoidance is not available then overall avoidance rates are best estimated by using monitoring data from existing windfarms, comparing actual mortality to that predicted if pre-construction levels of flight activity were maintained:

$$A_{\text{overall}} = 1 - \left\{ \frac{\text{Actual collision rate}}{\text{Predicted collision rate if pre-construction levels of flight activity were maintained}} \right\}$$

Care should be taken to ensure that the data on which such avoidance rates are based are on a consistent basis, having regard for example to the potential for changes in turbine model and flight risk heights as between those modelled in a collision risk assessment at the time of preparing an environmental statement, and those actually built.

80. In particular, if the extended model taking account of flight height distribution is used, **it is important that the calculations on which avoidance rates are based also start with a no-avoidance collision rate derived using the extended model.** Where the bird flight

density is skewed towards low altitude, a greater proportion of birds above the minimum risk height will miss the rotor, simply because, at a level close to rotor minimum height, the rotor circle intercepts relatively few flights. This is taken into account through the limits to the x integration in equations (9) and (10). This propensity to miss the rotor must not be confused with avoidance, which requires a behavioural response by a bird. Put another way, if an avoidance rate is calculated by comparing collision rate observations with a calculated avoidance rate using the basic (uniform flight density) model, then that avoidance rate will already include for the fact that low-flying birds will more often miss the rotor. Using such an avoidance rate in conjunction with the extended model would double-count that factor.

81. **All current flight activity should be included within a windfarm collision risk estimate, and the avoidance rates used for collision risk estimates should be characteristic of overall avoidance, ie they should include both macro avoidance (displacement or far-field avoidance) and micro (near-field or behavioural) avoidance.** In particular the likelihood of displacement should be included as an aspect of overall avoidance. Elsewhere in the bird impact assessment the potential direct impact of displacement on the bird population, in terms of reduction in available habitat, should also be assessed.
82. The lack of firm evidence surrounding avoidance rates will almost certainly dominate the uncertainty inherent in the collision risk estimate. For a few land-based bird species there is now substantial international experience on levels of avoidance from long-standing monitoring studies, such that some confidence can be placed in the assumption of high levels of avoidance. However for marine species there is limited firm data as yet on which to base predictions. It should be noted that avoidance behaviour may vary seasonally, and between groups of birds of the same species.
83. **The collision risk estimate should conclude with a table showing potential collision mortality using a range of assumed avoidance rates.** The text relating to this table should point to any evidence from existing post-construction monitoring on the respective or similar bird species which might indicate what levels of avoidance are best supported by evidence. As a default in the absence of specific avoidance information for the species in question, it is recommended that collision risks be evaluated assuming avoidance rates of 95%, 98%, 99% and 99.5%.

### **Attraction**

84. Offshore windfarms may create new habitat which encourages aggregation of fish, and as a result birds may be attracted into the windfarm for foraging. Lighting on wind turbines may also have an effect in attracting birds at night. Where such attraction occurs, it follows that collision risk may be enhanced as a result of increased flight activity through the windfarm. Attraction is in effect a form of 'negative displacement' and could in principle be included in the collision risk assessment by including an appropriate negative component in macro avoidance. However, in most circumstances there is not enough definitive evidence to make quantitative predictions on attracting birds with any certainty.
85. **Where, as part of an overall bird impact assessment, attention is drawn to the potential for a wind farm to attract birds, the potential for additional collision risk should also be considered.**

## STAGE F - EXPRESSING UNCERTAINTY

86. In a collision risk estimate following the above method, there are a large number of sources of variability or uncertainty in the output. The main sources of uncertainty are:

- survey data is sampled, often both in time and space, and usually exhibits a high degree of variability. Mean estimates can only be representative of flight activity
- survey data is unavailable for certain conditions, including night time and storm conditions
- natural variability in bird populations, over time and space, for ecological reasons
- flight height information may be subject to observer bias
- the collision risk model uses a simplified geometry for turbine blades and bird shape
- it does not include any risk of collision with turbine towers
- details of blade dimension and pitch may be unavailable at the time of making the estimate
- turbines deployed may differ from those used in the collision risk analysis
- bird parameters (length, wingspan, flight speed) have a distribution, they are not fixed
- bird speed is not a constant but is dependent on wind speed
- insufficient knowledge about bird displacement and attraction effects
- there is limited firm information on bird avoidance behaviour at sea

87. Perhaps the most important issue is to keep these uncertainties in proportion. For some of these uncertainties (eg bird density from survey data) the range of variability may be fairly clear from the variability between different survey days. Observer bias in flight height estimates may be tested, for example, by duplicating observers on occasion and comparing results. There are uncertainties in using the collision model itself, for example in using a single bird speed, or if the calculation is made for only one turbine speed rather than deriving an average over all turbine speeds. However these uncertainties are probably less significant than the errors introduced by variability in the survey data input.

88. Then there is uncertainty over avoidance behaviour. At present there is only a handful of bird species for which collision mortality at onshore windfarms has been sufficiently monitored to enable an avoidance rate to be used with confidence. For marine bird species, there is as yet limited information upon which to base a judgement on an appropriate avoidance rate to use. The uncertainty here ranges over an order of magnitude. If an avoidance rate of 98% is used, for example, that may be judged subject to uncertainty covering a range from 95% to 99.5%, representing non-avoidance behaviour between 5% and 0.5%. For the foreseeable future, it seems likely that the uncertainties surrounding bird avoidance behaviour are likely to dwarf the errors and uncertainties arising from an inexact collision model or variability in survey data.

89. A similar position relates to the extent to which birds may respond to habitat changes caused by the windfarm. Here also there is insufficient experience yet to be able to predict with confidence likely levels of displacement or attraction in response to new habitats, or indeed whether these patterns of behaviour will persist or change over time.

90. For these reasons it is proposed that uncertainty due to avoidance behaviour, and uncertainty over response to habitat changes, should be handled differently from uncertainties elsewhere in the calculation.

91. **The output should convey the uncertainty in the collision risk estimate, by indicating, in addition to a ‘best estimate’, a range of confidence around that estimate. Though it is unlikely (with the exception of the survey data) that these can be subject to detailed statistical analysis, the aim should be to express the range of uncertainty at around the 95% confidence level.**

92. The range of uncertainty should reflect

- uncertainty or variability in flight activity data (including imprecision on flight height estimates and lack of knowledge about night-time behaviour)
- uncertainty due to the limitations of the collision model, including the variability of bird dimensions and flight speed, the simplification in shape of a bird and turbine blades. As an expert guesstimate, the uncertainties arising from the collision model, if all required turbine parameters are fully available, may be of order  $\pm 20\%$ .
- uncertainty arising from turbine options yet to be decided, in number, size and speed, where that is consistent with the ‘Rochdale envelope’ flexibility described in guidance by the Infrastructure Planning Commission (2011)<sup>vi</sup>. These options should include a ‘worst case’ in terms of the option likely to present greatest bird collision risk.

The range of uncertainty due to each of these three sources should be separately identified and, as the three uncertainties are of independent origin, they may be combined to give an overall uncertainty of  $\sqrt{(u_1^2 + u_2^2 + u_3^2)}$  where  $u_1$ ,  $u_2$  and  $u_3$  are respectively the percentage uncertainties from each of these sources.

<b>Box 2: Example of presentation of uncertainty</b>			
(Note that the asterisked figures are chosen for example only and should be derived or judged from detailed consideration of the accuracies and uncertainties inherent in the input data.)			
Best estimate of annual collision risk (birds per annum) assuming 98% avoidance rate		147 *	
Range of uncertainty			
due to variance and uncertainty in flight activity	$\pm 50\%$ *		
due to simplifications in collision model	$\pm 20\%$		
due to design options yet to be finalised	$\pm 15\%$ *		
overall	$\pm \sqrt{(0.5^2 + 0.2^2 + 0.15^2)} = 0.56$	$\pm 56\%$	range 65 - 230

93. Where the extended model is applied using the generic height data from Cook et al<sup>iii</sup>, that paper provides confidence intervals around the median data points. The range of uncertainty relating to flight height can be estimated by replacing the median set of data (as shown in Sheet 5: Flightheight) by, respectively, the upper and lower 95% confidence levels, and noting the corresponding uncertainty in the collision risk.

94. **Finally, the output should state the effect on the collision risk of a range of assumptions on avoidance. This should be covered by a statement conveying the status of current information on avoidance behaviour of the bird species in question, noting any variability in this behaviour, and drawing conclusions about the likely collision risk.**

**Box 3: Example of presentation of uncertainty on avoidance**

Species: XXXXXXXX

Best estimate of annual collision risk (birds per annum)

assuming	95% avoidance	367	}	all subject to ± 56%
	98% avoidance	147	}	
	99% avoidance	73	}	
	99.5% avoidance	37	}	
	99.75% avoidance	18	}	

Information on avoidance for this species suggests 99% is most appropriate (refer to text in ES) but the lack of data means that the confidence interval may extend from 95% to 99.9%.

95. The collision risk estimate should also outline qualitatively the possible likelihood and scale of any further collision risks which might result from the wind farm attracting birds (see paragraphs 84/85).

**FOOTNOTE**

96. One risk of prescriptive guidance is that it could stifle innovation in improved methods. Developers and their advisors are encouraged where appropriate to go beyond the core requirements set out in this guidance; but where they do so, the standard approach of this guidance should also be pursued so as to make clear how the results of any improved methods differ from that of the standard approach.

## NOTES ON USING THE SPREADSHEET

The Excel spreadsheet which accompanies this guidance is intended to take the user easily through the first five stages of the process.

**Sheet 1: Input data** is provided so that all input data is input on this sheet. There are no calculations or calculated fields on this sheet. The user should not input data on any of the three following sheets 2-4, other than (if desired) to replace the blade profile in Sheet 3 with a more specific one for the actual turbine blades used. Sheet 1 is organised with blocks of input data on the bird species; on flight activity from bird survey; on migrant birds (to be used if relevant); on the windfarm; on the turbines to be used in the windfarm; and finally on the avoidance behaviour used in presenting the results.

The source data used for each input should be identified for easy reference on the spreadsheet, and the sources should be listed in full within the Environmental Statement.

**Sheet 2: Overall collision risk** is the master sheet bringing together all the calculations of Stages A through E, and concluding with overall collision estimates, given a range of assumptions on rates of avoidance:

- Stage A states the information on the density of flying birds, the proportion flying at risk height, and the time over which such bird activity persists.
- The sheet then presents the basic model (Option 1), giving
  - Output from Stage B - the estimated number of potential bird transits through rotors of the windfarm.
  - Output from Stage C - the probability of collision during a single bird rotor transit.
  - Output from Stage D - the potential collision mortality for the bird species in question, assuming current use of the site and no avoiding action is taken
- The sheet then re-applies the basic model, only using the value of  $Q'_{2R}$ , the proportion of bird flying at risk height derived from the flight height distribution (Option 2). For this purpose flight height distribution data must be loaded in the first two columns of the Flightheight sheet.
- Finally the sheet applies the extended model allowing flight height distribution to be taken into account (Option 3).
- Output from Stage E is the potential collision mortality for the bird species in question, taking avoidance and other likely behaviour change into account. The user must choose to which of the above set of results (Options 1, 2 or 3) the avoidance factors should be applied.

Sheet 2 draws in turn from Sheets 3-8. Sheet 2 will not display the results from the Extended model until Sheet 4 (Extended model) has been activated by clicking on that sheet, when it will automatically calculate. Once it has done so, Sheet 2 will display the appropriate results.

**Sheet 3: Single transit collision risk.** This sheet covers stage C of the process, calculating the probability of collision for a bird making a single passage through a rotor at each radius  $r$ , in increments from  $r/R=0.05$  out to  $r/R=1$ . The collision probability is then averaged over the entire area of the rotor disc, by summing the probability over successive concentric rings each of width  $0.05R$ , multiplying by the area of the successive concentric rings, and dividing by the total area  $\pi R^2$  of the rotor disk (see paragraphs 46/47). The method used is essentially a trapezoidal numerical integration. The calculation is undertaken separately for upwind and downwind flight, and an average taken.

**Sheet 4: Extended model.** It should be noted that this sheet requires macros to be enabled, as much of the functionality of this sheet is based on function routines programmed in Visual Basic. If at any stage calculations are not triggered automatically, press Shift-F9 to force recalculation.

This sheet repeats, in the panel at top right, the calculations of the basic model<sup>4</sup>. In the lower panel, this sheet carries out the calculations of the extended model, based on the flight height distribution data in the following sheet 'Flightheight'. The key calculated outputs are  $Q_{2R}$ , the flux integral, and the collision integral (for upwind and downwind flight and average of both). The sheet allows input of  $xinc$  and  $yinc$ , the increments used in the numerical integration. By default these are set to 0.05, ie one twentieth of a rotor radius. For increased precision these may be set to a smaller value like 0.01, but the worksheet calculation time may become significant.

This sheet also shows a table and a set of graphs derived from the table. The table shows the height  $y$  from rotor minimum to rotor maximum; the corresponding bird density  $d(y)$  (interpolated from the Sheet 5 data); the contribution of that horizontal strip of rotor at height  $y$  to risk (up and downwind), and the product of bird density and contribution to risk (up and downwind). The chart then presents these as line graphs. These calculations are all based on a value of 0.05 for  $xinc$  and  $yinc$ , the increments used in integration. The graphs are included to provide a live illustration of the effect of a skewed flight distribution. They show how the reduction of collision risk towards the rotor minimum height at  $y=-1$ , and the reduction in bird density due to the rapidly falling bird density with height, combine to squeeze the zone in which most collisions occur to an area just above  $y=-1$ .

Note that the table and graph are calculated entirely separately from the calculation of the Collision and Flux integrals, which make use of the user-input values of  $xinc$  and  $yinc$ .

**Sheet 5: Flight Height.** This sheet contains, in the first two columns, the flight height distribution used by Sheet 4 to calculate collision risk. Data is also shown for a number of other species, simply for ease of copying the data and pasting in to the first two columns. The standard form for this flight height distribution data is in 1m height intervals, with values of  $D_v(Y)/D_A$  such that the column totals to 1.0. A frequency distribution with a wider height interval may be used, but then  $D(Y)$  must be divided by the interval, such that the values properly represent relative bird density per metre of height, and the column will total to  $(1.0/\text{interval})$ .

**Sheet 6: Migrant collision risk.** This sheet undertakes a similar calculation of collision risk to Sheet 2, but makes use of information in a different form on the density of birds passing through the windfarm, such as may be available for migrating bird species - see Annex 6 for a full description.

**Sheet 7: Daylight and night hours.** Given the input latitude, this sheet computes the daylight and night hours in each month within which there could potentially be bird activity.

**Sheet 8: Large array correction.** This is an add-on, which enables a correction to be made for large arrays where the collision rate is such that bird density might significantly decline as birds pass through the windfarm. These correction factors are then applied to the collision rate estimates in Sheet 2 'Overall collision risk'. In most circumstances the results will demonstrate that a large array correction is not significant and can be ignored.

---

<sup>4</sup> There are small differences in the output values for gliding flight, as this sheet avoids a simplification in the earlier model



## Notes on input data

Care is needed throughout to use the correct units as specified below and in the spreadsheet. In the main standard SI units are used. However some of the inputs (eg bird density) use units which developed in use as a matter of common practice – as indeed are the outputs in terms of collisions per month.

All the following input data should be entered using Sheet 1 – ‘Input data’, unless information is available to use a blade chord profile specific to the turbine being used in the relevant columns of Sheet 3 – ‘Single transit collision risk’.

<b>Bird data</b>			
<b>Symbol</b>	<b>Description</b>	<b>Units</b>	<b>Notes</b>
	Species name		to help identify this spreadsheet
L	Length of bird	m (metres)	these should be drawn from standard reference works, eg Cramp & Simmons (1983) <sup>xiii</sup> or from BTO Bird Facts <sup>xiv</sup> .
W	Wingspan of bird	m (metres)	
v	Flight speed	m/sec	
F	Flight type		‘flapping’ or ‘gliding’ - the spreadsheet then applies the relevant factor $F = 0$ for flapping flight, or $+1$ for gliding flight
	Nocturnal activity factor	1-5 ranking from Garthe and Hüppop/ King et al	the spreadsheet converts this factor to 0%/ 25%/ 50%/ 75%/100% daytime activity

For flight speed, usually a typical mean flight speed as given in such standard references will be adequate. However, where there is a need to explore the collision risk arising from different types of bird behaviour involving very different flight speeds (eg pursuit, or foraging), then the collision risk calculation should separate out the risk for those birds engaged in each behaviour, and sum the collision risk, as this varies with flight speed in a non-linear way.

<b>Flight activity data</b>			
<b>Symbol</b>	<b>Description</b>	<b>Units</b>	<b>Notes</b>
$D_A$	Bird density (day)	birds/km <sup>2</sup>	Average number of birds in flight in daytime at any height, per square kilometre, as derived from field observation
$Q_{2R}$	Proportion at rotor height	%	% derived from bird survey, in the light of the projected rotor diameter and rotor hub height. The extended model also computes a figure for this, termed $Q'_{2R}$ to distinguish it
	Proportion of flights upwind	%	This should be set to 50% unless survey indicates a predominant direction relative to wind, eg for large-scale migration flights

**Flight activity data – additional for migrants** see Annex 6 for details

<b>Windfarm data</b>			
<b>Symbol</b>	<b>Description</b>	<b>Units</b>	<b>Notes</b>
	Latitude of windfarm	degrees latitude (including decimal places)	include degrees and minutes in degrees with decimal places; this data is used to work out daylight hours in each month
T	Number of turbines		
Q <sub>op</sub>	Proportion of time turbines are operational	%	This includes down-time for maintenance as well as time inactive because of low-wind or storm conditions
	Width of windfarm		optional; this is used only in the large array correction

<b>Turbine data</b>			
<b>Symbol</b>	<b>Description</b>	<b>Units</b>	<b>Notes</b>
R	Rotor radius	m (metres)	measured from the axis of rotation to blade tip. (This differs from the blade length, which is the length of the blade itself from where it is attached to the hub to the blade tip.)
H	Hub height	m (metres)	This is the height in metres of the rotor hub, ie the axis around which it rotates, above the sea surface taken as the Highest Astronomical Tide. In conjunction with the rotor radius and tidal offset, this determines the flight altitudes at risk. In the basic model this parameter is not used in the calculation but it is desirable to state it, as the proportion of birds flying at risk height is strongly dependent upon it. It is however a key parameter in the extended model.
	Tidal offset	m (metres)	This is the difference in metres between HAT (from which hub height is measured) and mean sea level Z <sub>0</sub> . The difference is typically 2-3m but may be up to 5m or more in estuarine locations
Ω	Rotation speed	rpm (revolutions per minute)	The spreadsheet converts to radians/sec as required in the underlying formulae
c	Blade chord width (along length)	m (metres)	see below
γ	Average blade pitch	degrees relative to rotor plane	see below

*Rotation speed* when generating of most contemporary turbines is variable within a pre-determined range. A time-averaged mean of operational rotor speeds should be used, taking account of the expected frequency of different wind speeds and the resulting projected operational speeds (see paragraphs 48-49).

Note that the Band 2000 version of this spreadsheet requires input of the Rotation Period, ie the time required for one full rotation of the rotor, which is the inverse of Rotation Speed:  $Rotation\ period = 1 / (Rotation\ speed\ in\ rpm)$

The underlying formulae make use of rotation speed  $\Omega$  expressed in radians per second. One complete revolution is  $2\pi$  radians, and there are 60 seconds in a minute, so  $\Omega = (rpm / 60) \times 2\pi$ , a conversion undertaken by the spreadsheet.

*Chord width.* The model considers a blade to be a twisted lamina, ie of zero thickness. It has a chord width, which varies along the length of the blade as it tapers towards the tip. The chord profile in the spreadsheet is typical of a modern 5MW turbine used for offshore generation.

*Pitch.* The blade also has a pitch angle – the angle between the blade surface and the axis of the rotor. Pitch angle varies along the length of the blade, from a high angle close to the hub, to a low pitch angle towards the blade tips, ie the blade is twisted. Pitch angle also varies as the pitch is controlled to alter the rotation speed of the turbine. In the model, an average angle is used, representing an average pitch along the blade length. 25-30 degrees is reasonable for a typical large turbine.

Note that it is the total cross-sectional area of all the rotors ( $T \pi R^2$ ) which is used to calculate the number of bird transits through a rotor. If the size and number of turbines is not known, a figure may be entered directly in Sheet 2 (Overall collision risk) for the 'total rotor frontal area': which may be amenable to a better estimate than either the turbine number or size.

### Avoidance data

These are the range of avoidance rates to be used when presenting the collision risk conclusions (see paragraphs 76-83). Use avoidance rates if possible which have been established from previous monitoring studies for this species, and an appropriate range to cover the uncertainties involved.

### Spreadsheet protection

To protect against unintentional overwriting of formulae, or the entry of input data other than in the 'Input data' sheet, each of the worksheets is 'protected', and the spreadsheet is fully usable in this state. Should there be a need to change or add to the spreadsheet, the protection can be turned off for any worksheet by going to 'Tools' – 'Protection' and setting to 'off' - there is no password protection in place.

### **Notes on spreadsheet programming**

The functionality of Sheet 4 (Extended model) is entirely based on computations programmed as user-defined functions in Visual Basic. Macros must be enabled. The programme code may be viewed using the 'Developer' tab and 'Visual Basic' icon. The user-defined functions are listed for reference in Annex 8.

## Annex 1 Oblique approach

The collision risk of a bird passing through a turbine is dependent on the angle of approach. If it approaches obliquely, the cross-sectional area presented by the rotor disk will be reduced, as the rotor presents an elliptical rather than circular cross-section to the bird.

**Fig A1-1: Effect of oblique approach**

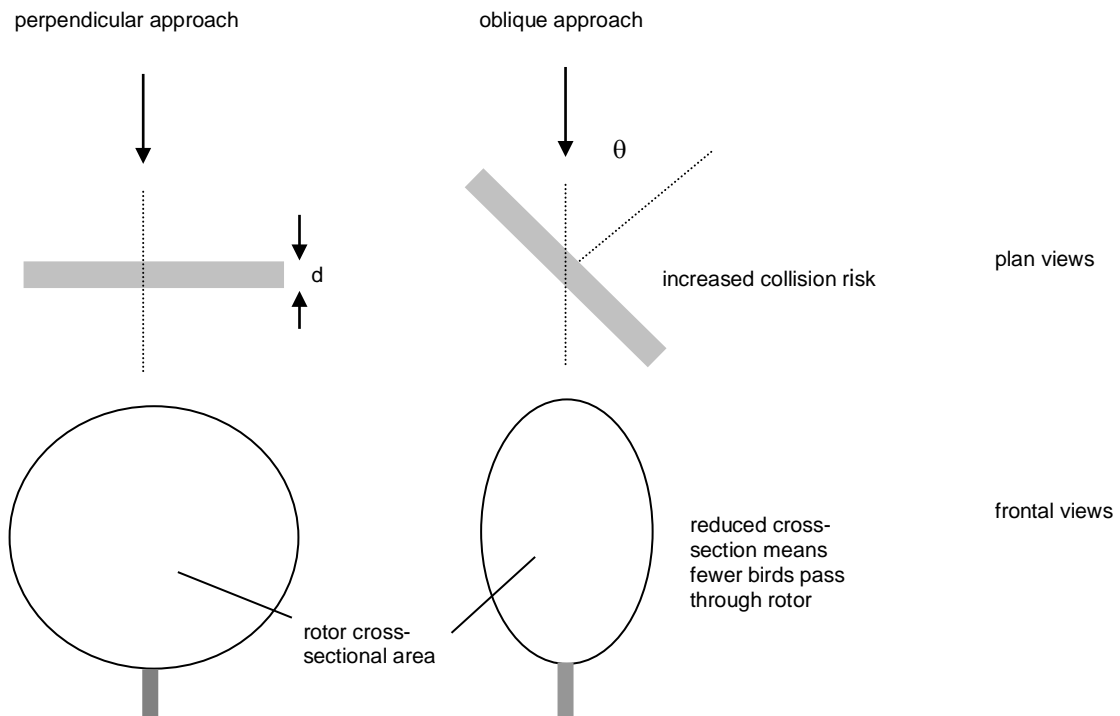

If the rotor has radius  $R$  and cross-sectional area  $\pi R^2$ , then to a bird incoming at an oblique angle  $\theta$  with respect to perpendicular approach, it presents a cross section  $\pi R^2 \cos \theta$ , thus reducing with  $\cos \theta$ .

However, if a bird approaching obliquely does pass through a rotor, its collision risk is greater than for a bird approaching perpendicularly, in part because of the increased time the bird takes to clear the full depth of the rotors from back to front, and in part because of the changes in speed of blade approach relative to a bird flying across (as well as towards) a rotor.

In relation to the first of these, a bird making a perpendicular approach has to clear a distance  $d + L$  in order not to collide with the blades,  $d$  being the depth of the rotor from front to back, and  $L$  being the length of the bird. A bird making an oblique approach has to clear a distance  $(d+L) / \cos \theta$ . The collision risk thus increases, in a first approximation, with  $1/\cos \theta$ . This 'oblique factor' thus cancels the reduction with  $\cos \theta$  due to the reducing cross-section presented by the rotor.

On this basis this guidance considers all bird flights as if they were perpendicular to the rotor plane, and uses the collision risk relevant to flights perpendicular to the rotor. With this simplification stages B and C can be followed sequentially.

However, this does not take account of the second of the above factors, the changes of blade approach relative to a bird flying across a rotor. This leads to a dependence on  $\theta$  of the collision risk for a bird making an oblique transit which is more complex than  $1/\cos \theta$ . In particular, an oblique approach leads to the wingspan rather than the length of the bird becoming the dominant element in determining the time it takes for the bird to pass through the rotor plane. Holmstrom et al (2011)<sup>xv</sup> have explored the dependence of collision risk on angle of approach, using a bird

modelled as a flat rectangle, building on the original analysis by Tucker (1996a and 1996b)<sup>xvi</sup>. They demonstrate that for large raptors flying downwind through a rotor, collision risk increases with an increasingly oblique angle of approach, reaching a maximum at around 30 degrees from perpendicular approach, then tailing off as the effect of the reduced cross-sectional area presented by the rotor begins to dominate. At the maxima, the collision risk is calculated to be between 10% and 31% higher than for perpendicular approach, dependent on bird parameters and wind speed. Averaged across all angles of approach, the increases for downwind flight may be of order 10-15%, though likely to be less for upwind flight. It is also probable that at values of  $\theta$  close to  $\pi/2$  (ie for flight nearly parallel with the rotor) collision risk rises steeply for birds passing through the rotor, though the likelihood of such an encounter is low because of the edge-on cross-section presented.

The spreadsheet approach accompanying this guidance does not deal with the complexity of oblique angled approaches. If a model for oblique approach were to be used, a stricter approach would require calculation of the number of flights *from each direction* passing through the swept area of the windfarm turbines, applying the probability of collision applying *for that direction*, and *summing these probabilities* for birds flying in all directions.

This guidance makes the simplifying assumption that all flights can be treated as perpendicular to the rotor plane (ie parallel to the rotor axis). This is equivalent to assuming a  $1/\cos \theta$  dependence of collision risk for a bird flying through a rotor at angle  $\theta$ , thus exactly cancelling the  $\cos \theta$  dependence of the number of birds flying through the rotor. In the light of the Holmstrom et al (2011) results, it should be recognised that this simplification may underestimate collision probabilities by a factor which, taking account of both upwind and downwind flights, may be of order 10% for large birds.

## Annex 2 Relationship between bird flux and bird density

There is a direct relationship between bird density and flux, which involves a dependence on the speed of the birds (if they were stationary, there would be no flux).

### Simplified approach – treating all flights as perpendicular to rotor

First, take a simplified approach in which birds fly either downwind or upwind through a circular rotor area  $A$ , but not at oblique angles. Within one second, all birds within the cylinder of base area  $A$  and length  $v$  will pass through the area  $A$ . So the flux  $F$  is

$$F = \frac{1}{2} D_v A v \quad \text{downwind} \quad \text{and} \quad = \frac{1}{2} D_v A v \quad \text{upwind}$$

where  $F$  is the bird flux per unit area,  $D_v$  is the bird density (true density) per  $\text{m}^3$  and  $v$  is the speed of the birds.

**Fig A2-1: Bird flux due to bird density** (copy of Fig 5)

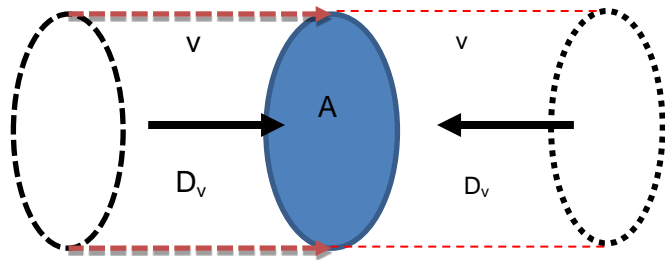

### General approach - random horizontal directions

More generally, if one assumes that the birds fly in a horizontal plane, but may fly in random horizontal directions, the flux is

$$F = (1/\pi) D_v A v \quad \text{downwind} \quad \text{and} \quad = (1/\pi) D_v A v \quad \text{upwind}$$

**Fig A2-2: Bird flux due to bird density – oblique approach**

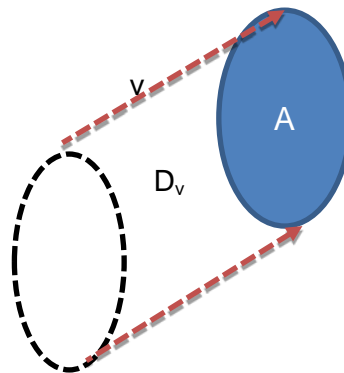

This takes account of the fact that at an approach angle  $\theta$ , the area  $A$  now looks like an ellipse, not a circle, and thus the volume of the squashed cylinder of length  $v$  containing the birds which will reach area  $A$  within one second is now  $A v \cos\theta$  rather than simply  $A v$  for the perpendicular approach. The proportion of birds flying at an approach angle between  $\theta$  and  $\theta + d\theta$  is  $(d\theta/2\pi)$ . Total flux from this upwind side is then

$$F = \int_{-\pi/2}^{\pi/2} (D_v / 2\pi) A v \cos\theta \, d\theta = (1/\pi) D_v A v \quad \dots \text{(A2-1)}$$

where  $F$  is the bird flux across the area  $A$ ,  $D_v$  is the bird density (true density) per  $\text{m}^3$  and  $v$  is the speed of the birds.

It should be noted that a flux measurement is directional – for a given density of birds moving in random horizontal directions, a unit area will intercept more birds flying perpendicular to the area

than birds flying at an oblique angle, to which the unit area will appear narrower. The  $(1/\pi)$  factor accounts for this angle-dependence.

Total bird flux, counting both upwind and downwind flights, is then

$$F_{\text{tot}} = (2/\pi) D_v A v \quad (\text{A2-2})$$

To convert from a bird flux measurement to a measurement of bird density, use the converse expression

$$D_v = (\pi/2) F_{\text{tot}} / (A v) \quad (\text{A2-3})$$

### Using areal bird density

The above refers to bird flux crossing an area such as a rotor disk, and relates it to the bird density  $D_v$  surrounding the rotor.

Flux is often referred to as the number of birds  $F_L$  flying across a horizontal line, per metre length of that line, at any altitude (as observed, for example, in vertical radar surveys). Taking an aerial view, that is the sum of birds crossing in each 1m band of height, for which the flux is given by equation A2-3:

$$\begin{aligned} F_L &= \sum_{h=0}^{h = \text{max height}} (2/\pi) D_v v \\ &= (2/\pi) v \sum D_v \end{aligned}$$

But summing the bird density within each successive metre height gives the areal bird density  $D_A$ . So we have

$$F_L = (2/\pi) D_A v \quad \text{birds/sec (per metre length of horizontal line)} \quad (\text{A2-4})$$

This equation is the equivalent, using areal density, of equation (A2-2) which uses true density.

The converse is the equivalent of equation (A2-3):

$$D_A = (\pi/2) F_L / v \quad \text{birds / m}^2 \quad (\text{A2-5})$$

### **Annex 3 - Probability of bird being hit when flying through the rotor**

*The following text is extracted from the Band (2000) guidance published on the Scottish Natural Heritage website. Text in italics has been updated to reflect changes in the accompanying spreadsheet.*

This stage computes the probability of a bird being hit when making a transit through a rotor. The probability depends on the size of the bird (both length and wingspan), the breadth and pitch of the turbine blades, the rotation speed of the turbine, and of course the flight speed of the bird. *The calculation assumes that a bird has an equal probability of passing at any point through the rotor.*

To facilitate calculation, many simplifications have to be made. The bird is assumed to be of simple cruciform shape, with the wings at the halfway point between nose and tail. The turbine blade is assumed to have a width and a pitch angle (relative to the plane of the turbine), but to have no thickness.

It is best to visualise this as in Fig A3-1, looking vertically down on the flying bird in a frame which is moving with the bird. In this moving frame, each rotor blade is both moving from right to left (say) and also progressing towards the bird. Each blade cuts a swathe through the air which depends both on the breadth of the blade and its pitch angle. Successive blades cut parallel swathes, but progressively closer to the bird. The angle of approach of the blade  $\alpha$ , in this frame, depends on both bird speed and blade speed. At the rotor extremity, where blade speed is usually high compared to bird speed, the approach angle  $\alpha'$  is low, ie the blades approach the bird from the side. Close to the rotor hub, where the blade speed is low and the bird is therefore flying towards a slow-moving object, the approach angle  $\alpha'$  is high.

The probability of bird collision, for given bird and blade dimensions and speeds, is the probability, were the bird placed anywhere at random on the line of flight, of it overlapping with a blade swathe (since the bird, in this frame, is stationary). It may therefore be calculated from simple geometric considerations. Where the angle of approach is shallow, it is the length of the bird, compared to the separation distance of successive swathes, which is the controlling factor. Where the angle of approach is high, it is the wingspan of the bird compared to the physical distance between blades, which is the controlling factor.



**Fig A3-1: Collision risk from flying through the rotor**

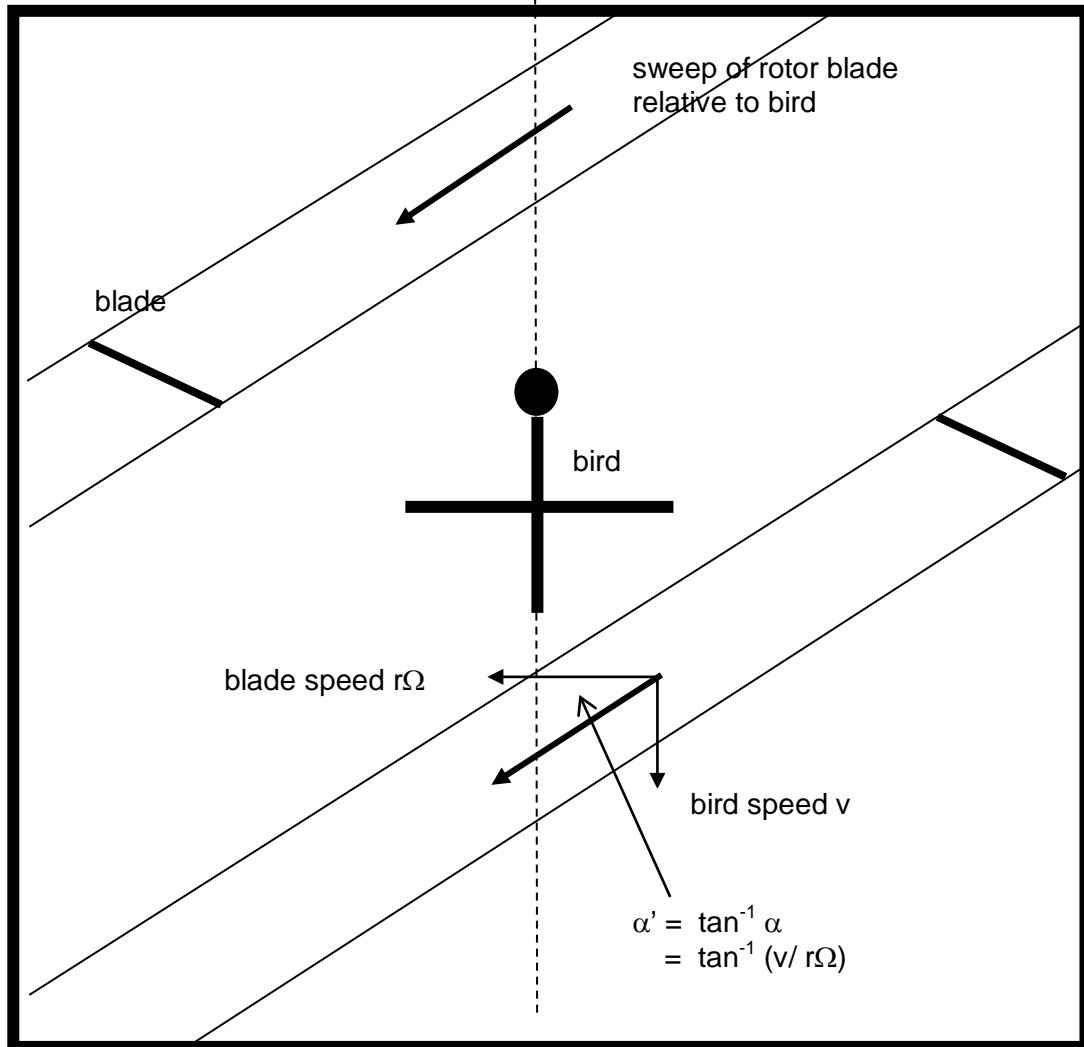

The calculation derives a probability  $p(r, \varphi)$  of collision for a bird at a radius  $r$  from the hub, and at a position along a radial line which is an angle  $\varphi$  from the vertical. It is then necessary to integrate this probability over the entire rotor disc, assuming that the bird transit may be anywhere at random within the area of the rotor disc:

$$\begin{aligned} \text{Total probability} &= (1/\pi R^2) \iint p(r, \varphi) r \, dr \, d\varphi \\ &= 2 \int p(r) (r/R) \, d(r/R) \end{aligned} \quad \dots \quad \text{(A3-1)}$$

where  $p(r)$  now allows for the integration over  $\varphi$ .

Probability  $p$  of collision for a bird at a radius  $r$  from hub

$$p(r) = (b\Omega/2\pi v) \left[ K \left| \pm c \sin\gamma + \alpha c \cos\gamma \right| + \begin{matrix} L & \text{for } \alpha < \beta \\ W\alpha F & \text{for } \alpha > \beta \end{matrix} \right] \quad \dots \quad \text{(A3-2)}$$

where  $b$  = number of blades in rotor  
 $\Omega$  = angular velocity of rotor (radians/sec)

- $c$  = chord width of blade  
 $\gamma$  = pitch angle of blade  
 $R$  = outer rotor radius
- $L$  = length of bird  
 $W$  = wingspan of bird  
 $\beta$  = aspect ratio of bird ie  $L / W$   
 $v$  = velocity of bird through rotor
- $r$  = radius of point of passage of bird  
 $\alpha = v/r\Omega$
- $F = 1$  for a bird with flapping wings, or  $= (2/\pi)$  for a gliding bird
- $K = 0$  for one-dimensional model (rotor with no zero chord width)  
 $= 1$  for three-dimensional model (rotor with real chord width)

The chord width of the blade  $c$  and the blade pitch  $\gamma$ , ie the angle of the blade relative to the rotor plane, vary from rotor hub to rotor tip. The chord width is typically greatest close to the hub and the blade tapers towards the tip. The pitch is shallowest close to the tip where the blade speed is highest. The apparent width of the blade, looked at from the front, is  $c \cos\gamma$ , and the depth of blade from back to front is  $c \sin\gamma$ .

The factor  $F$  is included to cover the two extreme cases:

- (i)  $F=1$ : where the bird has flapping wings. In this case  $p(r, \varphi)$  has no dependence on  $\varphi$ ; or
- (ii)  $F = 2/\pi$ : where the bird is gliding,  $p(r, \varphi)$  is dependent on  $\varphi$ , with a maximum above and below the hub, and a minimum at the sides when the wings are parallel with a passing rotor blade.

The sign of the  $c \sin\gamma$  term depends on whether the flight is upwind (+) or downwind (-).

The factor  $K$  is included to give a simple option of checking the effect of real blade width in the result:  $K=0$  models a one-dimensional blade with no chord width.

As  $\alpha$ ,  $c$  and  $\gamma$  all vary between hub and rotor tip, a numerical integration is easiest when evaluating equation (A3-1).

For ease of use these calculations are laid out on a spreadsheet. (*This is reproduced in an updated form in Sheet 3 'Single transit collision risk' in the spreadsheet accompanying this guidance. However the input data must now be entered through Sheet 1 'Input data'.*)

The spreadsheet calculates  $p(r)$  at intervals of  $0.05 R$  from the rotor centre (ie evaluating equation (A3-2)), and then undertakes a numerical integration from  $r=0$  to  $r=R$  (ie evaluating equation (A3-1)). The spreadsheet is set out as follows:

- 1 The input parameters are in the first two columns. Bird aspect ratio  $\beta$  is calculated.
- 2 Collision probabilities are then calculated for radii at intervals of  $0.05 R$  from the hub to the tip. Each radius is represented by a row in the table, with the value of the radius  $r/R$  in the first column..
3. The second column of the table is the chord width at radius  $r$  as a proportion of the maximum chord width. The taper will differ for different turbine blades. *The taper profile in the updated spreadsheet circulated with this guidance is based on the blade of a typical 5 MW turbine used for offshore generation.*
4. Factor  $\alpha$  is calculated.

5. The 'collide length' is the entire factor within square brackets within equation (2) above, using the upwind case.
6.  $p(\text{collision})$  is  $p$  at radius  $r$ , as calculated by equation (A3-2). It is however limited to a maximum value of 1.
7. 'contribution from radius  $r$ ' is the integrand of equation (A3-1) (including the factor 2) prior to integration.
8. The total risk is then the sum of these contributions.
9. The calculation is then repeated for the downwind case.
- 10 The spreadsheet then shows a simple average of upwind and downwind values. (Note that in a real case it may be important to add in the effect of wind to the bird's ground speed, and flight patterns may not be such that upwind and downwind flights are equally frequent.)

The result is an average collision risk for a bird passing through a rotor.

Note that there are many approximations involved, for example in assuming that a bird can be modelled by a simple cruciform shape, that a turbine blade has width and pitch but no thickness, and that a bird's flight will be unaffected by a near miss, despite the slipstream around a turbine blade. *Thus the calculated collision risks should be held as an indication of the risk - say to around  $\pm 20\%$ , rather than an exact figure<sup>5</sup>.* It is also simplistic to assume that bird flight velocity is likely to be the same relative to the ground both upwind and downwind. Ideally, separate calculations should be done for the upwind and downwind case, using typical observed flight speeds.

---

<sup>5</sup> In the 2000 version, the uncertainty was judged to be  $\pm 10\%$ . In the light of the possible effect of skewed flight distributions and the effects of oblique angle approach, as well as the various simplifications in the model, this advice is updated to  $\pm 20\%$  in the present guidance.

## Annex 4 - Large turbine arrays

The overall approach in this guidance calculates the rate of collision arising from each turbine independently operating in an airspace with a projected density of flying birds, and sums up the risk from all T turbines in the windfarm. In this approach, the size and layout of the windfarm are unimportant, if the density of flying birds is the same for all turbines.

For large turbine arrays where the overall probability of a bird colliding is relatively high, it may be appropriate to take account of the declining proportion of the birds surviving passage through early rows of turbines and thus exposed to collision risk in later rows. In effect, the density of flying birds surrounding turbines in later rows may be reduced as a consequence of collisions in earlier rows. (While it is convenient to think in terms of successive rows of turbines, the same principle applies within any array of turbines, even if located in a disordered array.)

For this, the overall size and layout of the windfarm are relevant. Here we need to consider the risk to a bird flying through the windfarm as a whole, which depends on how widely spaced the turbines are. Again maintaining the assumption of perpendicular approach to rotors, the collision risk for a single bird due to any one turbine (ie disregarding the risks to the bird presented by other turbines) is

$$c = (\pi R^2 / 2Rw) p Q_{op} (1-A)$$

where  $\pi R^2$  is the cross-sectional area of a single turbine,  $2Rw$  is the overall cross-sectional area of the windfarm of width  $w$  and risk height  $2R$ ,  $p$  is the collision risk for a bird passing through a rotor,  $Q_{op}$  is the proportion of time the turbine is operational, and  $A$  is the avoidance rate assumed.

Imagine an array of turbines with  $n$  rows of  $t$  turbines, each of which on its own would present a collision risk  $c$ . The overall collision risk for a single bird passage, if bird density depletion effects are ignored, would be simply  $C = ntc$ .

To take account of depletion, consider that the probability of incoming birds surviving a passage across the first row is  $(1-tc)$ , and the proportion attempting to pass through row 2 is therefore  $(1-tc)$ . The proportion surviving row 2 is  $(1-tc)^2$  and so on until:

$$\text{after row } n \text{ the proportion surviving is } (1-tc)^n \quad \dots \text{ (A4-1)}$$

which may be expanded as a convergent binomial series

$$(1-tc)^n = 1 - ntc + (n(n-1)/2) (tc)^2 - (n(n-1)(n-2) / 6) (tc)^3 + \dots$$

where the terms are successively smaller.

The 'large array collision risk'  $C_{LA}$  is  $(1 - \text{proportion surviving})$  ie

$$C_{LA} = ntc - (n(n-1)/2) (tc)^2 + (n(n-1)(n-2) / 6) (tc)^3 - \dots$$

The first term here is  $ntc = C$ , the risk from a single turbine multiplied by the number of turbines. The subsequent terms provide a correction to that value which takes account of bird density depletion.

Dividing throughout by  $C$  we get

$$C_{LA} / C = 1 - ((n-1)/ 2n) C + ((n-1)(n-2) / 6 n^2) C^2 - \dots \quad \dots \text{ (A4-2)}$$

Thus a first order correction to the value  $C$  given by the collision model can be made by subtracting  $((n-1)/2n) C$ . The  $C^2$  and subsequent terms are most likely to be insignificant.

**Box 4: Example of large array correction**

Take an array of  $T = 144$  turbines, rotor radius  $50\text{m}$ , in an array of width  $6\text{km}$ .

Assume input data

Probability of collision for single rotor transit =  $0.15$

Proportion of time operational =  $90\%$

Avoidance rate assumed =  $97.5\%$

$$C = T (\pi R^2 / 2Rw) p Q_{op} A$$

$$= (\pi \times 50 \times 50) / (2 \times 50 \times 6000) \times 144 \times 0.15 \times 0.9 \times 0.025 = 0.00636$$

Take number of rows  $n = \sqrt{T} = 12$

$$C_{LA} / C = 1 - ((n-1)/2n) C + ((n-1)(n-2)/6n^2) C^2 - \dots$$

$$= 1 - 0.0029 + 0.0000051 \dots$$

$$= 0.997 \text{ ignoring terms of order } C^3 \text{ and higher}$$

Thus 'Large array correction factor' =  $99.7\%$

Very often the layout of a windfarm is not known at the time of collision risk assessment, so an exact value for  $n$  is not known; and in any case the collision risk has to account for birds entering the windfarm from all directions. A rough approximation is to use  $n = \sqrt{T}$  ie the square root of the total number of turbines. If a more analytic approach is necessary, with discrimination between flight directions, then the model of Bolker et al (2006)<sup>xvii</sup> may be used.

If realistic avoidance rates have been taken into account in the collision model, such 'large array corrections' are likely to be small and can be ignored. However if the overall risk to a single bird passage is of order  $0.1$  or above, the large array correction will be significant. A spreadsheet is provided at sheet 8 'Large Array Correction' to enable the correction to be calculated easily. The output from this sheet is then applied in the final set of collision estimates in the 'Overall Collision Risk' spreadsheet.

## Annex 5 - Using flight height distributions – derivation of equations

Take a rotor disc of radius  $R$ , perpendicular to incoming bird flights at various heights  $Y$ . Assume that bird density  $D_v(Y)$  (in birds per  $m^3$ ) is a function of flight height;  $D_v(Y)$  is the 'flight height distribution'.

Using the same approach as in Figure 5 and equation (1) (paragraph 36) of the main text, consider the bird flux through a small element  $\delta A$  of the disc. Within one second all birds within a distance  $v$  on one side and flying towards the rotor will pass through the area  $\delta A$ , as in Figure A5-1. At any time there will be  $\frac{1}{2} v D_v(Y) \delta A$  flying towards the rotor in each direction. Total bird flux is

$$v D_v(Y) \delta A \quad \text{where } v \text{ is the bird flight speed} \\ \text{and } D_v(Y) \text{ is the bird flight density, per } m^3, \text{ at this height } Y$$

**Fig A5-1: Bird flux through small element of rotor disc**

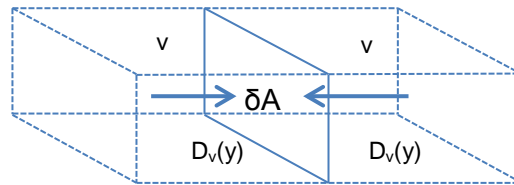

Take  $\delta A$  to be a small rectangle of width  $dX$  and height  $dY$ . If  $p(X,Y)$  is the probability of collision for a bird flying through the rotor at point  $(X,Y)$ , the collision rate through this small element  $\delta A$  at that point is

$$v D_v(Y) p(X,Y) dX dY$$

The total collision rate for flights through a single rotor disc (while the turbine is operational) is then obtained by integrating this over the whole area of the disc:

$$\text{Collision rate} = v \int_{\text{Min rotor height}}^{\text{Max rotor height}} D_v(Y) \int_{-\sqrt{R^2-Y^2}}^{+\sqrt{R^2-Y^2}} p(X,Y) dX dY \quad \dots \quad (\text{A5-1})$$

This is equation (7) (paragraph 67) of the main text. The limits  $\pm\sqrt{R^2-Y^2}$  to the integration over  $X$  define the outer limits of the rotor circle, and the limits to the integration over  $Y$  are the minimum and maximum rotor heights respectively.

Translate the factors into dimensionless units, within which the rotor has a radius of 1, by using the parameters  $x = X/R$ ,  $y=Y/R$ ; thus  $dX = Rdx$ ,  $dY = Rdy$ . Use the dimensionless relative frequency flight height distribution

$$d(y) = R D_v(Y)/D_A$$

$D_A$ , the areal bird density, is just the sum of  $D_v$  over all flight heights from sea level upwards, ie

$$D_A = \int_{\text{sea level}}^{\infty} D_v(Y) dY$$

Hence  $d(y)$  is normalised, ie

$$\int_{\text{sea level}}^{\infty} d(y) dy = \int R D_v(Y)/D_A (dY/R) = \int D_v(Y) dY / D_A = 1$$

Using these factors, equation (A5-1) becomes

$$\begin{aligned}
 \text{Collision rate} &= v (D_A/R) \int_{-1}^{+1} d(y) \int_{-\sqrt{(1-y^2)}}^{+\sqrt{(1-y^2)}} p(x,y) R dx R dy \\
 &= v D_A R \int_{-1}^{+1} d(y) \int_{-\sqrt{(1-y^2)}}^{+\sqrt{(1-y^2)}} p(x,y) dx dy \quad \text{(A5-2)}
 \end{aligned}$$

which when multiplied by the total number of turbines  $T$ , the time birds are active in a month  $t$ , and the proportion of time the turbines are operational  $Q_{op}$ , is equation (8) (paragraph 70) of the main text.

This can be rearranged in the form of equation (9) (paragraph 70) of the main text, so as to use the same 'flux factor' as in the basic model:

$$\text{Collisions} = \underbrace{v (D_A/2R) T \pi R^2 t}_{\text{Flux factor}} \times \underbrace{(2/\pi) \int_{-1}^{+1} \int_{-\sqrt{(1-y^2)}}^{+\sqrt{(1-y^2)}} d(y) p(x,y) dx dy}_{\text{Collision integral}} \times \underbrace{Q_{op}}_{\text{Proportion of time operational}} \quad \dots \text{(A5-3)}$$

The total count of birds passing through the rotors is given by the same equation but with  $p(x,y)$  set to 1, ie such that every bird is counted, as in equation (10) (paragraph 71) of the main text:

$$\text{Flux} = \underbrace{v (D_A/2R) T \pi R^2 t}_{\text{Flux factor}} \times \underbrace{(2/\pi) \int_{-1}^{+1} \int_{-\sqrt{(1-y^2)}}^{+\sqrt{(1-y^2)}} d(y) dx dy}_{\text{Flux integral}} \times \underbrace{Q_{op}}_{\text{Proportion of time operational}} \quad \dots \text{(A5-4)}$$

### Comparison with basic model

In the case where flight heights are assumed to be uniformly distributed across the risk height, ie from lowest to highest point of the rotor, then  $d(y)$  is a constant over the range  $y=-1$  to  $y=+1$  and can be taken in front of the integrals. Moreover, if all flights take place within this height band then  $d(y)$  takes the value  $1/2$ , because  $d(y)$  is normalised, ie  $\int_{-1}^{+1} d(y) dy = 1$ . The Flux integral then reduces to

$$(2/\pi) (1/2) \int \int dx dy = (2/\pi) (1/2) (\pi) = 1$$

as the integral is just the area  $\pi$  of a circle of unit radius. The Collision integral is simply the average of  $p(x,y)$  over the area of the disc.

More generally, if a proportion  $Q_{2R}$  of flights take place between minimum and maximum rotor heights, and the distribution is uniform within these limits,  $d(y)$  takes the value  $Q_{2R}/2$ , the Flux integral =  $Q_{2R}$ , and the Collision integral is  $Q_{2R}$  times the average of  $p(x,y)$  over the area of the disc.

The average of  $p(x,y)$  over the area of the disc is the 'single transit collision risk' in the basic model. Hence equation (A5-3) above becomes

$$\text{Collisions} = \text{Flux factor} \times Q_{2R} \times \text{Single transit collision risk} \times Q_{op}$$

This reproduces equation (5) (paragraph 52) of the main text, which describes the collision rate in the basic model.

## Annex 6 – Assessing collision risks for birds on migration

(DRAFT Extension to Collision Risk Guidance – Bill Band March 8 2012)

Birds on migration are often of particular interest in collision risk assessment, as the birds may be coming from or be heading for a distant site with conservation designations which imply special legal responsibilities in avoiding adverse impacts on the bird population. It will therefore be important to understand the impact of a given windfarm on such a bird population if its migration routes are through the windfarm. Report SOSS-05 by BTO on 'Assessing the risk of offshore wind farm development to migratory birds designated as features of UK Special Protection Areas'<sup>xviii</sup> describes the issues and uncertainties involved in such an assessment.

Calculating collision risk for migrants is little different from the process for other birds, and may make use of the Collision Risk Spreadsheet provided with this Guidance<sup>xix</sup>. The main difference arises in estimating the number of migrant birds passing through the windfarm, and how that data is input to the spreadsheet. The data is usually in terms of the number of birds passing through a migration corridor, rather than starting with bird density, as does the normal process in following the Collision Risk Guidance. To facilitate this, an additional sheet 'Migrant Collision Risk' has been added to the suite of spreadsheets, and to make use of this sheet, additional data on migrants is required in the 'Input Data' sheet.

### Estimating total bird flux over the migration period

Report SOSS-05 outlines a number of different methods which may potentially be used to estimate the number of birds flying through a windfarm. Each of these leads directly to information on bird flux density  $F$  – the number of birds passing through a tall window of unit width (a metre, or a kilometre) during each migration period.

- In the simplest approach, it may be assumed that an entire bird population uses a migratory corridor twice each year. Report SOSS-05 provides data on the total GB (also international) populations of a range of migratory species. Documentation for individual conservation sites often provides information on the typical occupancy of the sites by species during migration. The maps in the SOSS-05 report may then be used to estimate the width  $W$  (km) of the corridor used for migration – the 'migratory front', and the assumption may be made that the entire population of  $N$  birds passes through this migratory front, with an even distribution across the front. Thus the bird flux density is  $N/W$  birds  $\text{km}^{-1}$ .
- Instead of assuming an even distribution of birds over the migratory front, tracking studies can help indicate the proportion of a bird population likely to cross a wind farm (or different parts of a wind farm) during an average migration period.
- Migrant birds may be counted along with other birds in the snapshot counts in boat-based surveys. As boat based surveys are usually undertaken on a 1- or 2-days a month sample basis, they are generally unsatisfactory as a means of counting birds on migration: whether or not a flock of migrating birds is observed on sampling occasions, and the size of that flock, is likely to be a matter of chance. However, where the sampling is sufficiently frequent it may be used to generate an estimate of the total number of birds flying across the site during the migration period.
- Finally, the flux of migrant birds may be recorded by visual observation from shore or from a sea platform, or by radar, where the observation period covers a high proportion of the possible migration period. Such data will be measured directly in birds crossing an imaginary baseline, eg of 1km length, ie in birds  $\text{km}^{-1} \text{hour}^{-1}$ , and can be grossed up for the complete migration period. If this measurement is of birds approaching the baseline from all directions, the result should be multiplied by  $\pi/2$  to convert to the equivalent 'perpendicular flux' (see Annex 2). This allows for the fact that the 'tall window' through which birds may pass – defined by the baseline and extending to all heights - presents a reduced cross-sectional area to birds approaching from an oblique angle.



## Calculating the Flux factor

Equation (2) (paragraph 37) of this Guidance indicates:

Total number of bird transits =

$$\boxed{v (D_A / 2R) (T \pi R^2) \text{ (time active)}}$$

flux factor

$$\times \boxed{Q_{2R}}$$

proportion at risk height

where  $v$  is the bird flight speed,  $D_A$  the areal density of birds (ie flying at any altitude),  $T\pi R^2$  is the total cross-sectional area of all rotors, and  $Q_{2R}$  is the proportion of birds flying at risk height.

The data assembled above for birds on migration is on flux density  $F$  - the number of birds passing through a tall window of unit width (a metre, or a kilometre) during each migration period. To relate that to bird density, note that if all birds were flying perpendicularly to the window<sup>6</sup>, in any second the number flying through the window would be those within a distance  $v$  where  $v$  is the flight speed. As the total density of birds, summing over all heights, is  $D_A$  birds  $m^{-2}$ , the number within distance  $v$  of a window one metre wide, and hence about to pass through that in the next second, is just  $D_A v$ . Over a period of time  $t$ , the total number of birds passing through this window is thus  $D_A v t$ . So, over a full migration period,  $v D_A$  (time active) may be replaced in the above equation by  $F$ , in units of birds  $m^{-1}$ :

Total number of bird transits through rotors

$$\boxed{F (T \pi R^2) / 2R} \times \boxed{Q_{2R}} \quad \dots \quad (A6-1)$$

flux factor

proportion at risk height

Note that  $F$  is commonly expressed in birds  $km^{-1}$  and if so must be divided by 1000 (as the spreadsheet does) for use in this formula.

## Flight height

Cook et al 2012<sup>iii</sup>, in their SOSS-02 report, have documented the typical flight heights of many bird species at sea, as recorded in wind farm surveys around the UK and elsewhere. However, data on flight heights of birds on migration is patchy, as described by Wright et al in their SOSS-05 report. The proportion of birds on migration  $Q_{2R-m}$  flying at risk height is likely to be different from the  $Q_{2R}$  proportion for non-migrants. Table 3 of the SOSS-05 report makes recommendations on the values to be used for  $Q_{2R-m}$  for various species groups, ranging from 100% for raptors to 50% for passerines. For seabirds, divers, gulls and terns use is recommended of the values listed in the SOSS-02 report.

## Flight speed

The single transit collision risk uses the bird flight speed as a factor, so if a different flight speed  $v_m$  is available for migrating birds, this should be used.

## Migration period

Usually, the collision risk of interest will be over a full year, ie over outward and return migration periods. The spreadsheet is arranged, like the 'Overall collision risk' sheet, on a monthly basis. If data is available to support a monthly subdivision, the migration fluxes should be apportioned out over the relevant months. As the proportion of time that the wind farm is operational varies from month to month, this is the most accurate approach. However, if the distribution of migration passages over months is not known or highly variable, any two convenient months (eg April and September) may be used as the assumed migration periods.

<sup>6</sup> in accord with the assumption of perpendicular approach – see paragraph 12 of main text

## Calculating collision risk

Subject to the modified approach outlined above in calculating the Flux factor, the calculation of collision risk follows exactly the same methodology as for other birds. As in the usual approach, the Collision Risk Spreadsheet offers three options for calculating collision risk:

- (1) Option 1 - using the assumption that flights at risk are evenly distributed across all rotor heights;
- (2) Option 2 - ditto, but using the proportion of birds flying at risk height as derived using flight height distribution data; and
- (3) Option 3 - making use of the flight height distribution data to calculate risk in each part of the rotor, and summing that risk.

For some species groups, Table 3 of the SOSS-05 report indicates that a simple percentage should be entered for  $Q_{2R-m}$ . This indicates that the flight height distributions documented in Cook et al<sup>iii</sup> are not likely to be characteristic of migrating birds. Only Option (1) should be used, unless good data is available indicating the flight height distribution of migrating birds.

For those species groups where Table 3 indicates the Cook et al data may be used, then Options (2) and (3) may be used. As in the usual approach, it is recommended that for these species the calculations for all three Options should be presented, so as to note the effect of taking an assumed flight height distribution into account.

## Use of options to take account of flight height distribution

		SOSS-05 Table 3 recommendation	
Calculation option		Percentage	Use figure from Cook et al
Option 1	assume flights uniformly distributed across risk height	●	○
Option 2	use species flight height distribution to generate $Q_{2R-m}$		●
Option 3	use species flight height distribution in full to calculate collision risk		●

## Uncertainties

One of the main uncertainties is likely to be the uncertainty in flight activity, due to uncertainty and year-to-year variation in the number of birds migrating, and in the precise flight corridor used. Realistic assessments should be made, even if this is no more than an expert view, on the limits within which 95% confidence can be assured for the value of flux density input to the model.

## Supplementary notes on using the spreadsheet

The 'Input data' sheet now includes:

- 'bird survey data', which includes data on bird density. This drives the 'Overall collision risk' sheet which provides the overall collision risk calculation for the birds described in terms of bird density.
- 'birds on migration data', which includes the number of migration passages, the width of the migration corridor, the proportion of migrants flying at risk height, and the proportion of migratory flights which are upwind. This drives the 'Migrant collision risk' sheet which provides the collision risk calculation for the birds included in this 'birds on migration' block.

Therefore, to avoid double-counting collisions, the 'bird density' figures should exclude any migrants for which collision risk is calculated using the 'Migrant collision risk' sheet.

The spreadsheet does not add the two collision elements together, as they are likely to be used for different purposes.

The 'Migrant collision risk' spreadsheet only differs from the 'Overall collision risk' spreadsheet in the data used on flight activity (as above) and in the resulting calculation of the Flux factor. All other parameters – Bird data, Windfarm data, Turbine data and Avoidance rates – are common to both spreadsheets.

**Notes on additional input data**

<b>Flight activity data – additional for migrants</b>			
<b>Symbol</b>	<b>Description</b>	<b>Units</b>	<b>Notes</b>
N	Bird population	birds	This is the total number of birds migrating through the migration corridor in question. May be subdivided by month if there is data to support that.
W	Width of migration corridor	km	
Q <sub>2R-m</sub>	Proportion at rotor height	%	Based on recommendations in Table 3 of Report SOSS-05, unless bettered by new data.
	Proportion of migratory flights upwind	%	This is set at 50% by default, but for migration flights it may be appropriate to assume some bias towards downwind.

## Annex 7 - Taking account of tidal variation

This section considers how to take account of changing tidal levels in calculating bird collision risks. It is assumed that the extended collision model – taking account of flight height distribution – is being used.

The flight height distribution  $D(Y)$  describes the relative density of bird flights at different heights above the sea surface. However (other than for floating wind turbines) the height of the rotor above the sea surface varies with the tide. The issue to be addressed is how to take account of that variation in the calculation of collision risk.

### Height above Mean Sea Level

In order to satisfy navigational clearance requirements, turbine hub heights are usually expressed in metres above Highest Astronomical Tide (HAT), which is the maximum sea height theoretically possible, excluding waves and surges and other sea conditions due to meteorological conditions. To use bird flight height distributions, these heights need to be adjusted to the height above actual sea level.

Tidal information is normally presented in metres above Chart Datum (CD), with mean tidal level  $Z_0$  and a tidal variation which oscillates around that level. If turbine height is  $H$  relative to HAT, then it becomes  $H + (HAT - Z_0)$  relative to mean sea level. Thus a tidal offset has been added to the height:

$$\text{Tidal offset} = \text{Highest Astronomical Tide (HAT)} - \text{Mean Sea Level (Z}_0\text{)}$$

Typically this offset is in the range 2.5 - 4 metres. A new 'tidal offset' field has been included (in the extended version Mar 2012) as an input field in the 'Input Data' sheet in the Collision Risk Spreadsheet. The extended model then includes this adjustment to rotor heights when making use of a bird flight height distribution.

This adjustment in expressing turbine height can make a significant difference to collision risk, for some species reducing the estimated risk by around 25% to 30%. The size of the change depends on both species and turbine details, depending on the rate at which the flight height distribution curve varies around the minimum height of the rotor.

### Allowing for sea level rise

Current predictions on sea level rise due to climate change are described in UKCP09<sup>xx</sup>. By 2060 the predictions are typically for a rise of order 0.25 – 0.3 metres for a global high emissions scenario.

The aim as far as possible should be for bird collision risk assessment to be valid for the full operational period of the project. Therefore the height of the rotor relative to sea level should be reduced by an amount to take account of the likely increase in sea level over the lifetime of the windfarm. It is recommended that this reduction should be of order 0.25 – 0.3 metres. This should be done by amending the tidal offset, so that it becomes

$$\text{Tidal offset} = \text{Highest Astronomical Tide} - \text{Mean Sea level} - \text{Climate change adjustment}$$

### Tidal variation

The above takes account of the height of the rotors above mean sea level, but it does not take account of the variation of the tides. Assuming that the distribution of bird flight heights relative to sea level is independent of the state of the tide (which may not be the case in estuarine or near-shore locations), at times of high tide there will be increased bird density at rotor level, and at low tide decreased. If the flight height distribution were linear with height, then the increases at high tides would exactly offset the decreases at low tides. But flight height distributions are typically highly non-linear, and there is a 'second-derivative' effect, dependent on the degree of curvature in the flight height distribution, with the increases at high tides more than outweighing the

decreases at low tides. Only the section of the flight height distribution above rotor minimum height is relevant to collision risk, so it is the curvature of the distribution at those heights which matters.

This non-linear effect – the ‘tidal asymmetry correction’ - is in general small, but a method for calculating it is set out here.

Calculation of tidal asymmetry correction factor

Take all heights Y as measured with respect to mean sea level. At height Y above mean sea level, the flight density takes the value D(Y) only briefly, twice each tide as the tidal level passes the mean sea level. More generally, the flight density is D(Y-h) when the tide is h metres above mean sea level. The time-averaged flight density is

$$D\sim(Y) = \sum f(h) D(Y-h) \tag{A7-1}$$

where the sum is over all tidal height bands from lowest to highest, and f(h) is the proportion of time that the sea level is within each height band h.

Figure A7-1 shows the frequency of sea levels f(h) at one site (Cromer in East Anglia), ranging from -2.3m to + 2.3m, and banded within 0.2m height bands. Commercial tidal prediction software is available, such as the POLPRED Offshore tidal computation software available from the National Oceanographic Centre, which can generate such a sea level frequency chart with a high level of accuracy for any point in and around the UK<sup>xxi</sup>. For coastal sites near to ports, the ‘Notes on using the spreadsheet’ below describe how an approximate frequency chart can be generated, given basic tidal data published by the National Oceanographic Centre<sup>xxii</sup> on their Website, using the ‘Sea Level Frequency’ spreadsheet provided with this guidance. For Figure A7-1, tide level was calculated at 12 min intervals over 1 year and allocated to 0.2m wide bins. The curve shows symmetrical peaks at around mid-tide levels ±0.9m – not only do all tides pass through that level, but neap tides have their ‘high tide’ turning point in mid-range. In contrast, relatively few tides approach the maximum of the tidal range. Tides are changing most rapidly as they pass the mean sea level, so the curve is characterised by a dip in the middle.

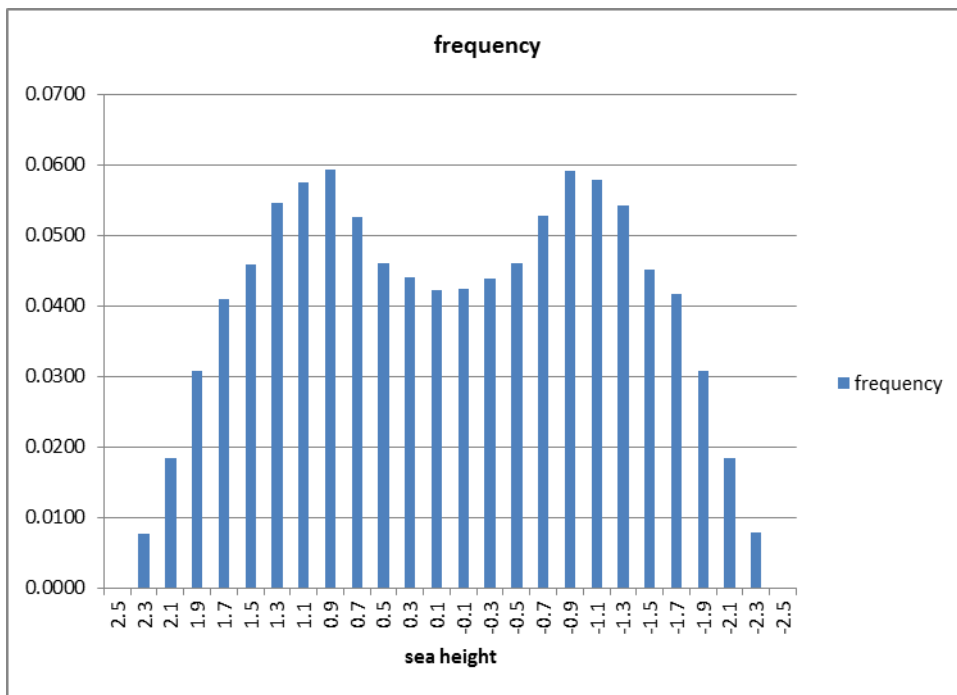

**Figure A7-1: Sea level frequency at Cromer, East Anglia**

The effect of applying the distribution of tides f(h) to the flight height distribution, ie applying equation (1), is to ‘smear’ the flight height distribution, drawing from a range within ±2.3 metres (for this site) higher or lower, to yield a time-averaged flight height distribution D~(Y). D~(Y) may now be used in place of the original flight height distribution D(Y) in the collision calculation,

pasting it in place of D(Y) as the 'current data' in column B of the Flightheight sheet of the Collision Risk Spreadsheet.

Table A7-2 shows sample output for the time-averaged flight density of kittiwake, under the tidal regime at Cromer. The original flight height distribution is from the work by Cook et al SOSS<sup>iii</sup>, and the sea level frequency distribution is that in Figure A7-1.

Effects of smearing height distribution

Table A7-1 shows the effects of applying such smearing to flight height data for gannet, kittiwake and fulmar at a sample of five sites around the coast of the UK. The tidal data given is for ports, that for offshore sites may differ.

**Table A7-1: Effects of using a tidally-smearred flight height distribution**

Base tidal information:

	tidal range (springs)*	HAT	Z <sub>0</sub>	tidal offset
Stornoway	4.14	5.53	2.893	2.64
Aberdeen	3.62	4.85	2.557	2.29
Heysham	8.49	10.76	5.176	5.58
Cromer	4.23	5.74	2.920	2.82
Avonmouth	12.27	14.65	6.955	7.69

The data below is calculated using the same 4MW turbine scenario as in the Worked Example: 3 blades, 9.9rpm, 57.5m rotor radius, 80m hub height, 4.21m max chord, 15 degree pitch.

\* tidal range in metres, taken as difference between mean high water spring tides and mean low water spring tides

Gannet	tidal range	collision integral x 10 <sup>3</sup>		
		without tidal smear	with tidal smear	change
Stornoway	4.14	<b>1.288</b>	<b>1.309</b>	<b>+1.6%</b>
Aberdeen	3.62	<b>1.347</b>	<b>1.363</b>	<b>+1.2%</b>
Heysham	8.49	<b>0.931</b>	<b>0.989</b>	<b>+6.2%</b>
Cromer	4.23	<b>1.259</b>	<b>1.284</b>	<b>+2.0%</b>
Avonmouth	12.27	<b>0.784</b>	<b>0.860</b>	<b>+9.7%</b>

bird length 0.94, wingspan 1.72, flight speed 14.9, flight style flapping, 50% upwind

Kittiwake	tidal range	collision integral x 10 <sup>3</sup>		change
		without tidal smear	with tidal smear	
Stornoway	4.14	1.131	1.139	+0.7%
Aberdeen	3.62	1.176	1.184	+0.7%
Heysham	8.49	0.816	0.847	+3.8%
Cromer	4.23	1.108	1.118	+0.9%
Avonmouth	12.27	0.649	0.697	+7.4%

bird length 0.39, wingspan 1.08, flight speed 14.9, flight style flapping, 50% upwind

Fulmar	tidal range	collision integral x 10 <sup>3</sup>		change
		without tidal smear	with tidal smear	
Stornoway	4.14	0.059	0.059	-
Aberdeen	3.62	0.061	0.060	-
Heysham	8.49	0.049	0.049	-
Cromer	4.23	0.058	0.058	-
Avonmouth	12.27	0.043	0.043	-

bird length 0.48, wingspan 1.07, flight speed 14.9, flight style flapping, 50% upwind

The effects of the smearing are highly dependent on the species. This is to be expected as the concave-upwards curvature of the flight height distribution, in the lower height range of range of the rotors, differs markedly for different species. Both gannet and kittiwake distributions have strong curvature in this height range, while the fulmar height distribution has flattened off at these heights above the sea surface.

The effects also depend on the tidal range, reflecting in particular the separation of the two peaks in the sea level distribution curve. The effects are generally small (less than 5% of collision risk) except at the two high-tidal range sites, Heysham and Avonmouth. The latter has among the most extreme tides in the UK. For gannet at Avonmouth, the effect is 9.7% of collision risk. That means that the collision risk is increased by 9.7% due to the asymmetry of the flight height distribution. (It should be stressed that these are proportional changes – ie if predicted collisions were 50 per month this effect would raise that estimate to 54.85.)

While for most potential offshore windfarm sites such effects may be judged minimal, at sites with tidal range in excess of 5 metres it may be sufficiently significant to warrant incorporation of use of a 'tidal asymmetry correction'.

The correction increases with tidal range, more than just linearly. As it depends on the curvature of the flight distribution curve, ie its second derivative, it should be expected to depend on the square of the breadth of the distribution (which is characterised by the tidal range). Making this assumption and using the data in Table A7-1 yields very approximate 'rule of thumb' factors:

### **Correction factors** (percentage adjustment of collision risk):

Gannet	$0.08 \times (\text{tidal range})^2$
Kittiwake	$0.05 \times (\text{tidal range})^2$
Fulmar	0

Thus, for gannet at Cromer where the collision integral is  $1.259 \times 10^{-3}$ , one should apply a tidal asymmetry correction of  $0.08 \times (4.23^2) = 1.43\%$ , raising the collision integral to

$$\text{Adjusted collision integral} = 1.259 \times 1.0143 \times 10^{-3} = 1.277 \times 10^{-3}$$

Where species other than the above three are involved, there will be a need to undertake a comparable analysis to establish the 'rule of thumb' factors.

It should be noted that these rule-of-thumb factors have been evaluated for one particular (fictitious) turbine model. However it may be expected to apply to any large turbine with a similar height clearance above the sea surface: the crucial factor is the degree of curvature of the flight height distribution curve for the species in question, in the vicinity of the lower reaches of the rotor.

### Conclusion

Given the additional data processing required to take account of this adjustment, it is not recommended that the effects of tidal asymmetry should be taken into account routinely in collision risk assessment. However, where the tidal range exceeds 5m, the adjustment is significant enough to warrant use of a correction, using the 'rule of thumb' factor if the species is one for which such a factor has been established, and if not, by undertaking the analysis outlined above.

### **Summary of recommendations**

The following recommendations only apply to turbines which are fixed relative to the seabed (ie not floating turbines)

1. For the purposes of collision risk assessment, turbine hub and blade heights should be adjusted so they are relative to mean sea level, by including the height of Highest Astronomical Tide above Mean Sea Level as a 'tidal offset'.
2. A reduction of around 0.25 – 0.3 metres in that offset should be made to allow for the likelihood of increasing sea levels over the period to 2060.
3. The skewed distribution of seabird flight heights means that tidal variation affects bird densities in an asymmetric way, ie the increases at higher sea levels are greater than the decreases at lower sea levels. The changes to collision risk are typically small (<5%). However at sites with a high tidal range (> 5 metres) the effects for some species may be significant. A 'rule of thumb' correction factor is provided for gannet, kittiwake and fulmar. For other species there will be a need to apply the methodology outlined above to establish the correction. Tools are provided in spreadsheet form to assist this process.

### **Spreadsheet support**

A spreadsheet 'Tidal smear' is provided which contains a routine to 'tidally smear' data, ie using D(Y) as input and calculating D~(Y) as output.

Two ancillary spreadsheets 'Tidal height' and 'Sea level frequency' are also included which enable an approximate sea level frequency distribution to be generated for near-coastal sites, if software such as POLPRED is not available.



These are intended for users conversant with spreadsheets and with an understanding of the transformation required; the process involves cutting and pasting data between worksheets. Notes on using these spreadsheets are provided below.

### Notes on using the spreadsheets

These spreadsheet tools involve some cut-and-pasting and use of macros so should be undertaken by someone with adequate spreadsheet skills. There are three sheets in the 'Tidal variation' workbook.

Tidal height uses published tidal data to generate tidal predictions. Tidal data for ports around the UK is published by the National Oceanography Centre at <http://www.pol.ac.uk/ntslf/tidalp.html>.

Sea level height, ignoring any meteorological effects such as surges or waves, is governed by a series of cycles with different frequencies, relating to the position of the moon and sun in relation to the earth and the location in question. Sea level height is given, where  $t$  is the time in hours elapsed from a reference start time, by the formula

$$\sum H_i \cos (\sigma_i t - g_i)$$

where for each cyclical component  $i$ ,  $H_i$  is the amplitude,  $\sigma_i$  its angular frequency, and  $g_i$  its phase.

Based on observations over the period 1989 – 2007, the National Oceanography Centre publishes information on amplitude  $H_i$  and phase  $g_i$  – the 'harmonic constants' - for the four largest cyclical constituents, termed  $M_2$ ,  $S_2$ ,  $K_1$  and  $O_1$  respectively. Their associated frequencies  $\sigma_i$  are drawn from a description of the Doodson numbers [http://en.wikipedia.org/wiki/Arthur\\_Thomas\\_Doodson](http://en.wikipedia.org/wiki/Arthur_Thomas_Doodson) (see  $w_0$ ,  $w_1$ ,  $w_2$  and  $w_3$  in the sample programme).

The spreadsheet uses these four principal harmonic constants and their associated phases and frequencies to calculate sea level at times  $t$  which increases in steps in successive rows. 'Step' sets the period in hours between successive rows.

This tidal calculation is not used directly, but provides a graph showing alternation of tides and springs and neap tides, which will help explain the shape of the sea level frequency distributions produced next.

It is stressed that this is a very approximate tidal series. More precise prediction involves the addition of a long series of harmonic components, not just four. If greater precision is required, then tidal predictions from various commercial systems may be used. However, these four harmonic components are sufficient to generate the broad pattern of spring and neap tides, and the daily alternation of tide heights, which should be adequate as a basis for a sea level frequency distribution.

Sea level frequency runs exactly the same routine as a time series. As it runs, it categorises each output in a tide height bin, building up a frequency distribution of sea level heights. As input it requires the same table of tidal constants for the location in question as the Tidal height sheet. The programme is initiated as a macro 'Sealevel frequency' - click on 'Developer' then 'Macros' and 'Run' the macro 'Sealevelfrequency'. The programme requires three further inputs:

*bin width* – use 0.2 for east coast or north coast, use 0.4 or 0.5 for estuarine locations. The distribution matrix is 13 times this bin width both + and -, so 0.2 bin width runs from -2.6m to +2.6; 0.5 bin width runs from -6.5m to +6.5m.

*interval* – a value of 0.2 (meaning 0.2 hours or 12 minutes) seems satisfactory, remembering that the aim is to sample sea level heights.

*number of data points* – the system should be tested with only 100 or 1000 points, but once working, run it for 45000 which at 12 minute intervals is a little over a year.

The output is a sea level frequency table, which is then normalised in the next column (divided by the total to give a frequency set which adds to 1). This normalised frequency distribution can then be copied then pasted into the Tidal smear spreadsheet.

Tidal smear uses the sea level frequency data as input, and applies it to the flight height distribution (eg that in the SOSS report by Cook et al<sup>iii</sup>), as described above, to produce a 'smeared' output, in which  $D\sim(Y)$  is the time-averaged value of the bird density at height Y. The programme uses two named ranges 'tidefreq' which contains the sea frequency data, and 'gannetdata' (for example) which contains the bird flight height distribution. Both ranges must be two columns wide, the left one with the height in metres, and the right one with the normalised frequency data. The ranges must start at the first data point (ie not including column titles). The sea level data ranges must be 26 rows deep, and the bird data tables 150 rows deep. The output column then uses the function 'tidesmear' to compute the result for each height y. Note that if the sea level frequency distribution runs from say -5m to +5m, then at height y metres the programme will draw from distribution data from y-5 to y+5 metres. So omit the output formula for heights 0-5m and 145-150 metres to avoid the programme going out of range.

The output tide-smeared distribution may then be copied and pasted into the main Collision Risk Assessment spreadsheet, in the 'Flightheights' sheet.

**Table A7-2: Sample output of tide-smear flight distribution  
Kittiwake, using tides at Cromer**

height (m)	original flight height distribution	tide-smear flight height distribution				
0	0.08571			48	0.00048	0.00049
1	0.07850			49	0.00042	0.00043
2	0.07175			50	0.00038	0.00038
3	0.06526			51	0.00033	0.00034
4	0.05987	0.06039	<div style="border: 1px solid black; padding: 5px; display: inline-block;">                     This bracket shows the range of data drawn upon in calculating the smeared distribution for height 4m                 </div>	52	0.00030	0.00030
5	0.05499	0.05548		53	0.00026	0.00027
6	0.05095	0.05100		54	0.00023	0.00024
7	0.04680	0.04686		55	0.00021	0.00021
8	0.04263	0.04299	56	0.00018	0.00019	
9	0.03907	0.03938	57	0.00016	0.00017	
10	0.03590	0.03606	58	0.00015	0.00015	
11	0.03293	0.03302	59	0.00013	0.00013	
12	0.02997	0.03022	60	0.00012	0.00012	
13	0.02747	0.02763	61	0.00010	0.00010	
14	0.02505	0.02530	62	0.00009	0.00009	
15	0.02305	0.02317	63	0.00008	0.00008	
16	0.02118	0.02122	64	0.00007	0.00007	
17	0.01929	0.01940	65	0.00007	0.00007	
18	0.01765	0.01760	66	0.00006	0.00006	
19	0.01587	0.01584	67	0.00005	0.00005	
20	0.01398	0.01419	68	0.00005	0.00005	
21	0.01247	0.01264	69	0.00004	0.00004	
22	0.01115	0.01127	70	0.00004	0.00004	
23	0.00999	0.01009	71	0.00003	0.00003	
24	0.00895	0.00902	72	0.00003	0.00003	
25	0.00801	0.00805	73	0.00003	0.00003	
26	0.00710	0.00718	74	0.00003	0.00003	
27	0.00631	0.00639	75	0.00002	0.00002	
28	0.00565	0.00568		etc		
29	0.00496	0.00504				
30	0.00444	0.00447				
31	0.00391	0.00395				
32	0.00345	0.00350				
33	0.00305	0.00309				
34	0.00271	0.00273				
35	0.00238	0.00242				
36	0.00213	0.00214				
37	0.00185	0.00189				
38	0.00164	0.00166				
39	0.00145	0.00147				
40	0.00128	0.00130				
41	0.00113	0.00115				
42	0.00101	0.00103				
43	0.00092	0.00092				
44	0.00081	0.00081				
45	0.00071	0.00072				
46	0.00063	0.00063				
47	0.00055	0.00056				

## Annex 8 Notes on spreadsheet Visual Basic functions

The functionality of Sheet 4 (Extended model) is entirely based on computations programmed as user-defined functions in Visual Basic. Macros must be enabled. The programme code may be viewed using the 'Developer' tab and 'Visual Basic' icon to view 'Module 1'. The user-defined functions are as follows:

### **interpolate (N,a,y)**

Assumes a set of points and associated values in a two-column named range A. It compares y with the set of points and performs a linear interpolation to provide an appropriate intermediate value. It is used twice in the programme: once to extract intermediate values of the chord  $c/C$ , using the data table in the Single Transit Risk sheet; and to extract appropriate values of bird density using the table of flight height data in sheet 'Flightheights'. If N is greater than the length of the named range A, an error message appears, but N is allowed to be less than the range length.

### **pcoll (r, $\phi$ , updown)**

Calculates the single transit collision risk at point  $(r, \phi)$  in the rotor, using equation (3). The parameter updown may be either 'up' or 'down'.  $r$  is in dimensionless form, ie  $r = \text{actual radius}/\text{rotor radius}$ .  $\phi$  is in degrees, where  $\phi=0$  is the top of the rotor.

### **pcoll\_rav (r, updown)**

Calculates the average of  $\text{pcoll}(r, \phi, \text{updown})$  over angles  $\phi$ , in 10-degree increments.

### **pcollxy (x,y,updown)**

Calculates the single transit collision risk at point  $(x,y)$  in the rotor, by converting  $(x,y)$  to  $(r,\phi)$  and calling  $\text{pcoll}(r, \phi, \text{updown})$ .  $x$  and  $y$  are in dimensionless form ie  $x=X/R$ ,  $y=Y/R$  (see Fig 7).

### **xareasum (y)**

Calculates the length of a horizontal chord at height  $y$

### **xrisksum (y,xinc,updown)**

Integrates the collision risk times bird density along a horizontal chord at height  $y$ , using the interpolate function to evaluate the bird density at this height. The parameter  $xinc$  is the increment used for integration along the  $x$ -axis.

### **ydistsum (xinc,yinc,updown,flag)**

When  $\text{flag}=0$ , integrates the collision risk times bird density over all heights from  $y=-1$  to  $y=+1$ . This is the double integral within the 'collision integral' box in equation (9). The Collision integral is  $(2/\pi)$   $\text{ydistsum}$ .

When  $\text{flag}=1$ , integrates bird density only over all heights from  $y=-1$  to  $y=+1$ . This is the double integral within the 'Flux integral' box in equation (10). The Flux integral is  $(2/\pi)$   $\text{ydistsum}$ .

The parameter  $yinc$  is the increment used for integration along the  $y$  axis.

## REFERENCES

---

SOSS Website is <http://www.bto.org/science/wetland-and-marine/soos/projects>

- <sup>i</sup> Band, W. (2000). Windfarms and Birds: calculating a theoretical collision risk assuming no avoiding action. Scottish Natural Heritage Guidance Note. <http://www.snh.gov.uk/planning-and-development/renewable-energy/onshore-wind/assessing-bird-collision-risks/>
- <sup>ii</sup> Band, W., Madders, M. and Whitfield, D.P. (2007). Developing field and analytical methods to assess avian collision risk at windfarms. In De Lucas, M., Janss, G. and Ferrer, M. (eds) 'Birds and Wind Power'. [www.quercus.pt](http://www.quercus.pt)
- <sup>iii</sup> Cook, A.S.C.P., Wright, L.J., and Burton, N.H.K. (2012). A Review of flight heights and avoidance rates of birds in relation to offshore windfarms. Crown Estate Strategic Ornithological Support Services (SOSS), project SOSS-02.
- <sup>iv</sup> Camphuysen, C.J., Fox, A.D., Leopold, M.F., and Petersen, I.K. (2004). Towards standardised seabirds at sea census techniques in connection with environmental impact assessments for offshore wind farms in the UK. Cowrie 2004.
- <sup>v</sup> Krijgsveld, K.L., Fijn, R.C., Heunks, C., van Horssen, P.W., Poot, M.J.M., and Dirksen, S. (2008). Egmond aan Zee: Progress report on fluxes and behaviour of flying birds pp25/26. [http://www.noordzeewind.nl/files/Common/Data/OWEZ\\_R\\_231\\_T1\\_20080304%20Flying%20birds.pdf](http://www.noordzeewind.nl/files/Common/Data/OWEZ_R_231_T1_20080304%20Flying%20birds.pdf)
- <sup>vi</sup> McAdam, B.J. (2005) Quantifying the effects of bird flight height and wind conditions on the mortality risk from wind farms. MSc thesis, University of Aberdeen (unpublished) describes the reduction in risk for low flight heights.
- <sup>vii</sup> Infrastructure Planning Commission (2011). Advice Note 9: Rochdale Envelope. <http://infrastructure.independent.gov.uk/wp-content/uploads/2011/02/Advice-note-9.-Rochdale-envelope-web.pdf>
- <sup>viii</sup> Forsythe, W.C., Rykiel, E.J., Jr, Stahl, R.S., Wu, H., & Schoolfield, R.M. (1995). A model comparison for daylength as a function of latitude and day of year. *Ecological Modelling*, 80, 87-95.
- <sup>ix</sup> Garthe, S. and Hüppop, O. (2004) Scaling possible adverse effects of marine wind farms on seabirds: developing and applying a vulnerability index. *J. Appl. Ecol.* 41: 724–734.
- <sup>x</sup> King, S., Maclean, I.M.D., Norman, T., and Prior, A. (2009). Developing guidance on ornithological cumulative impact assessment for offshore wind developers. COWRIE.
- <sup>xi</sup> This follows up a recommendation made in a review of the earlier model, for which the author is grateful: Chamberlain, D, Freeman, S, Rehfishch M, Fox, T, Desholm, M (2005). Appraisal of Scottish Natural Heritage's Wind Farm Collision Risk Model and its Application. BTO Research Report 401.
- <sup>xii</sup> Use of avoidance rates in the SNH wind farm collision risk model. Scottish Natural Heritage Information and Guidance Note (2010). <http://www.snh.gov.uk/docs/B721137.pdf>
- <sup>xiii</sup> Cramp, S. and Simmons, K.E.L. (1983). Handbook of the birds of Europe, the Middle East and North Africa: The birds of the Western Palaearctic. Oxford University Press.
- <sup>xiv</sup> BTO Bird Facts: [www.bto.org/about-birds/birdfacts](http://www.bto.org/about-birds/birdfacts) British Trust for Ornithology, website.
- <sup>xv</sup> Holmstrom, L.A., Hamer, T.E., Colclazier, E.M., Denis, N., Verschuyf, J.P. and Ruché, D. (2011). Assessing Avian-Wind Turbine Collision Risk: an Approach Angle Dependent Model. *Wind Engineering* 35(3) (in press).
- <sup>xvi</sup> Tucker, V.A. (1996a) A mathematical model of bird collisions with wind turbine rotors, *ASME Journal of Solar Engineering* (118) 253-262. Also Tucker, V.A. (1996b) Using a collision model to design safer wind turbine rotors for birds. *ASME Journal of Solar Engineering* (118) 263-270.
- <sup>xvii</sup> Bolker, E.D., Hatch, J.J., and Zara, C. (2007). Modeling bird passage through a windfarm.

---

<sup>xviii</sup> Wright, L.J., Ross-Smith, V.H., Massimino, D., Dadam, D., Cook, A.S.C.P., and Burton, N.J.K. (2012). Assessing the risk of offshore wind farm development to migratory birds designated as features of UK Special Protection Areas (and other Annex 1 species). The Crown Estate Strategic Ornithological Support Services (SOSS) report SOSS-05. BTO and the Crown Estate. SOSS Website.

<sup>xix</sup> Band, W (2012). Using a collision risk model to assess bird collision risks for offshore windfarms. The Crown Estate Strategic Ornithological Support Services (SOSS) report SOSS-02. SOSS Website. Original published Sept 2011, extended to deal with flight height distribution data March 2012.

<sup>xx</sup> UKCP09 sea level changes estimates.  
<http://ukclimateprojections.defra.gov.uk/content/view/2009/500/>

<sup>xxi</sup> POLPRED Offshore Tidal Computation Software is available from the National Oceanography Centre, [www.noc.ac.uk](http://www.noc.ac.uk). It enables predictions of tides and currents in the seas around the UK. It can generate a time series of sea levels over a period of years, and a sea level frequency distribution akin to that in Fig 1. Data generated can be downloaded into an Excel spreadsheet for input to the data handling process described above.

<sup>xxii</sup> National Oceanography Centre <http://www.pol.ac.uk/ntslf/tidalp.html>