



Deployment of a Shallow Water
Wave Energy Converter
at the
EMEC Billia Croo Test Site

**Environmental Report and
Project-specific Environmental
Monitoring Plan**

April 2018

Contents

1	Summary	4
2	Introduction	5
2.1	Purpose of the document	5
2.2	Structure of the document	5
2.3	Environmental Appraisal process	5
2.4	Deployment location	7
2.5	Technical summary of the project	9
3	Environmental Description	10
3.1	Benthos	10
3.2	Plankton	10
3.3	Fish and shellfish	11
3.4	Birds	11
3.5	Marine mammals	13
3.6	Protected sites	14
4	Project Description	15
4.1	WEC Description	16
4.2	WEC Installation	21
4.3	WEC maintenance	21
4.4	WEC decommissioning	22
4.5	Protection of the WEC	22
5	Environmental Appraisal Summary	23
5.1	Impact Identification and Assessment	23
5.2	Mitigation and Management	25
5.3	Commitments Register	26
5.4	Reporting Schedule	26
	Annex 1: Identification of potential impacts due to activities of the WEC, mitigation and management measures and residual impact significance	28
	Annex 2: Monitoring and Mitigation Plan	33
1	Introduction	33
2	Environmental Monitoring	33
3	Risk identification and evaluation	34
4	Proposed Management and Mitigation measures	37
	Annex 3: Commitments Register	40

List of Tables

Table 1: Impact significance definition.....	7
Table 2: Billia Croo navigational cardinal buoy and berth two location	7
Table 3: Laminaria proposed licence boundary coordinates.....	7
Table 4: Bird species observed at the Billia Croo test site	12
Table 5: Marine mammal species (inc. basking shark) observed at Billia Croo	13
Table 6: Designated sites located in close proximity to the Billia Croo test site	14
Table 7: Main Dimensions of the Laminaria WEC	17
Table 8: Potential key environmental impact pathways	23
Table 9: Reporting Schedule.....	27

Annex 2: Monitoring and Mitigation Plan

Table 1: Evaluation of risk and mitigation strategy of the potential environmental effects	34
Table 2: Mitigation and management measures.....	37
Table 3: Commitments Table	40

List of Figures

Figure 1: Indication of the Billia Croo wave energy test site	8
Figure 2: Indication of the deployment area of the Laminaria WEC ¹	8
Figure 3: Schematic sketch of the WEC movement (pitch), the changing mooring line layout and the movement of the mooring lines on the drum-system	17
Figure 4: Drawing of the main floater with attached PTO chambers	18
Figure 5: Drawing of the WEC assembly during the towing	18
Figure 6: Sketch of the Laminaria WEC	19
Figure 7: Front and side view of the Laminaria WEC (drawing).....	19
Figure 8: Bottom view of the Laminaria WEC.....	19
Figure 9: Drawing of the gravity base anchor	20
Figure 10: Drawing of the gravity base anchor (front view).....	20
Figure 11. Drawing of the gravity base anchor (top view).....	21

1 Summary

This Project-specific Environmental Report and Environmental Monitoring Plan (PEMP) will support the Marine Licence application of the Belgian wave energy developer Laminaria NV. Laminaria will install their first full-scale Wave Energy Converter (WEC) at the wave energy test site Billia Croo of the European Marine Energy Centre (EMEC) in August 2018.

The WEC consists of a buoyant Power Take Off (PTO) system (the main floater) and will be connected by four individual mooring lines to a variable buoyancy gravity base anchor. The mooring lines will transfer the main floater movements towards the PTO systems located at the bottom of the floater to convert the incident wave energy to electricity.

This document will give an overview of the environmental conditions of and around the Billia Croo wave energy test site to provide a base for the identification of potential environmental impacts of the WEC (main floater and anchor) during the deployment period. This information includes details about the existing marine species, occurrences regarding the periods of the year, benthos and existing protected sites around Billia Croo.

Potential environmental impacts of the WEC have been identified during the Environmental Appraisal process. In order to decrease or manage these potential impacts, monitoring and mitigation measures have been established. The main potential impact identified is the disturbance of marine wildlife due to underwater noise and vibration produced by the WEC and the mobilisation of marine vessels. Due to the WEC's design, the time required for installation and decommissioning is drastically reduced. The WEC can be installed during one day by the utilisation of one small work vessel and one multi-cat vessel. Due to these marine vessels and the short on-site time required for the installation of the WEC, potential environmental impacts are reduced.

To identify the potential environmental impacts of the WEC occurring during the deployment period at EMEC, several monitoring equipment will be deployed to gain a greater understanding of the device's interaction with the environment. These include: noise sensor, camera, temperature, load, water ingress, electrical and GPS monitoring. Additional mitigation measures will be identified for future deployment projects.

2 Introduction

The following Environmental Report (ER) and Project-specific Environmental Monitoring Plan (PEMP) has been produced in order to provide regulatory authorities, advisers and key stakeholders with an outline of the existing environment at the deployment site, Billia Croo, and the potential environmental impacts arising from the WEC presence, installation, operation and decommissioning.

2.1 Purpose of the document

The ER and PEMP has been prepared by Laminaria to support the Marine Licence application for the first full-scale Laminaria WEC deployment at Billia Croo. The document states that the potential environmental effects occurring are kept within acceptable limits in compliance with conditions of consent in relation to environmental impacts. Potential environmental impacts have been identified throughout the Environmental Appraisal process and a summary of the results is stated in this report. Annex 2 of this document states the monitoring and mitigation plans of Laminaria, this document will be updated during the deployment period accordingly. Additionally, the ER includes a description about the overall project and the working principal of the technology to give a full understanding of the potential environmental impacts.

2.2 Structure of the document

This section gives an overview of the structure and content of the PEMP document:

Section 1 – Summary: the summary briefly describes the content of this PEMP and indicates the main potential environmental impacts of the Laminaria WEC.

Section 2 – Introduction: the introduction describes the purpose of this document, the Environmental Appraisal process Laminaria fulfilled to identify the potential environmental impacts and details of the deployment location at Billia Croo.

Section 3 – Environmental Description: this part of the PEMP describes the environmental conditions around the wave energy test site Billia Croo. It includes information about marine species, occurrences regarding the periods of the year and identifies protected sites close to the area.

Section 4 – Project Description: the project description gives a brief overview of the Laminaria WEC, the installation method and details about the WEC protection during the deployment period

Section 5 – Environmental Appraisal Summary: this part gives an overview of the identified potential environmental impacts of the Laminaria WEC and the implemented mitigation and monitoring measures.

2.3 Environmental Appraisal process

The Environmental Appraisal process assesses the potential impacts on relevant environmental receptors during the installation, operation, maintenance and

decommissioning phases of the project. This part of the report provides an overview on how the assessment process was followed.

This assessment has been completed to understand: what impacts are of most concern, what the magnitude of the impact is from the device and cumulatively across the site, how the impacts will be minimised and managed, and what is the potential for residual impacts.

In order to assess the potential significance of the impacts from the Laminaria WEC, the baseline conditions must be understood. A desk-based study of EMEC's documentation, including the original site description documents and site sensitivity tables, was conducted and summary of the key receptors provided below. The process undertaken to identify the impact pathways is outlined below:

1. Identify both the environmental changes from the Laminaria WEC (all project phases) and associated works and the features of interest (i.e. receptors) that could be affected;
2. Understand the nature of the environmental changes in terms of: their exposure characteristics, the natural conditions of the system and the sensitivity of the specific receptors
3. Evaluate the vulnerability of the features as a basis for assessing the nature of the impact and its significance; and
4. Manage any impacts which are found to be significant and require the implementation of impact mitigation measures; identify the significance of any residual impact.

To determine the significance of the impact, it is necessary to firstly determine the significance of the receptors involved in the impact and secondly assess the magnitude of the effect that may arise. The sensitivity of the receptor can be determined by considering the vulnerability of receptor, recoverability of the receptor (i.e. the ability to accommodate change) and the value or importance of the receptor (this is linked to frequency). Whilst evaluating and predicting the magnitude of the impact on the environment, the following factors have been considered: spatial extent, impact duration, impact reversibility and impact likelihood. By combining the magnitude of the impact and sensitivity of the receptor, the significance of the impact can be evaluated. Table 1 provides the definitions used to categorise the significance of the impact. Where an impact's significance level has been classified as moderate or major, this has been classified as significant.

Monitoring measures have not been limited to impact pathways classified as significant, as Laminaria are supportive of understanding the environmental interactions associated with the WEC. All mitigation and management measures have been included and will be tracked through the Commitments Register.

Table 1: Impact significance definition

Significance level	Description
Major	Effects are highest in magnitude and reflect the high vulnerability and importance of the receptor (e.g. to nature conservation). Where these changes are adverse they will require mitigation. This will cause a significant change in environmental conditions causing breaches of legislation. Likely to impact on receptors of national or international importance. Likely to affect a large-scale area or a high number of receptors on frequent or permanent basis. May be an irreversible decline.
Moderate	Unlikely to cause a breach in legislation but likely to impact on a receptor of regional or local environmental importance. Likely to affect a small number of receptors on a permanent basis. Where these changes are adverse they may require mitigation.
Minor	Effects tending to be discernible but tolerable. Only likely to impact an area or feature of local interest or importance. Likely to have a temporary impact or be recoverable.
Negligible	Insignificant change with no discernible effect

Following implementation of mitigation measures, the impact significance was reassessed to understand the impact significance, determining the residual impact. Any residual impacts that remain significant will be discussed further in the report.

2.4 Deployment location

The Laminaria WEC will be deployed in berth two of the Billia Croo wave energy test site. Table 2 and

Table 3 indicate the coordinates of the boundaries of the Billia Croo area, the berth two location and the proposed boundaries for the Laminaria WEC during the deployment period.

Table 2: Billia Croo navigational cardinal buoy and berth two location

Location	Latitude	Longitude
North cardinal buoy	59° 00.000'N	003° 24.330'W
West cardinal buoy (1)	58° 58.529'N	003° 24.638'W
West cardinal buoy (2)	58° 59.500'N	003° 25.330'W
South cardinal buoy	58° 57.431'N	003° 23.028'W
East cardinal buoy	58° 58.386'N	003° 22.399'W
Berth two	58° 58.586'N	003° 23.335'W

Table 3: Laminaria proposed licence boundary coordinates

Location	Latitude	Longitude
North west corner	58° 58.753'N	003° 23.354'W
North east corner	58° 58.592'N	003° 22.928'W

South west corner	58° 58.444'N	003° 23.358'W
South east corner	58° 58.598'N	003° 23.768'W

The following figures indicate the Billia Croo wave energy test site (Figure 1: Indication of the Billia Croo wave energy test site) which can be clearly identified by the indicated marker buoys. The yellow square in Figure 2: Indication of the deployment area of the Laminaria WEC¹ roughly indicates the deployment location of the Laminaria WEC in berth two.

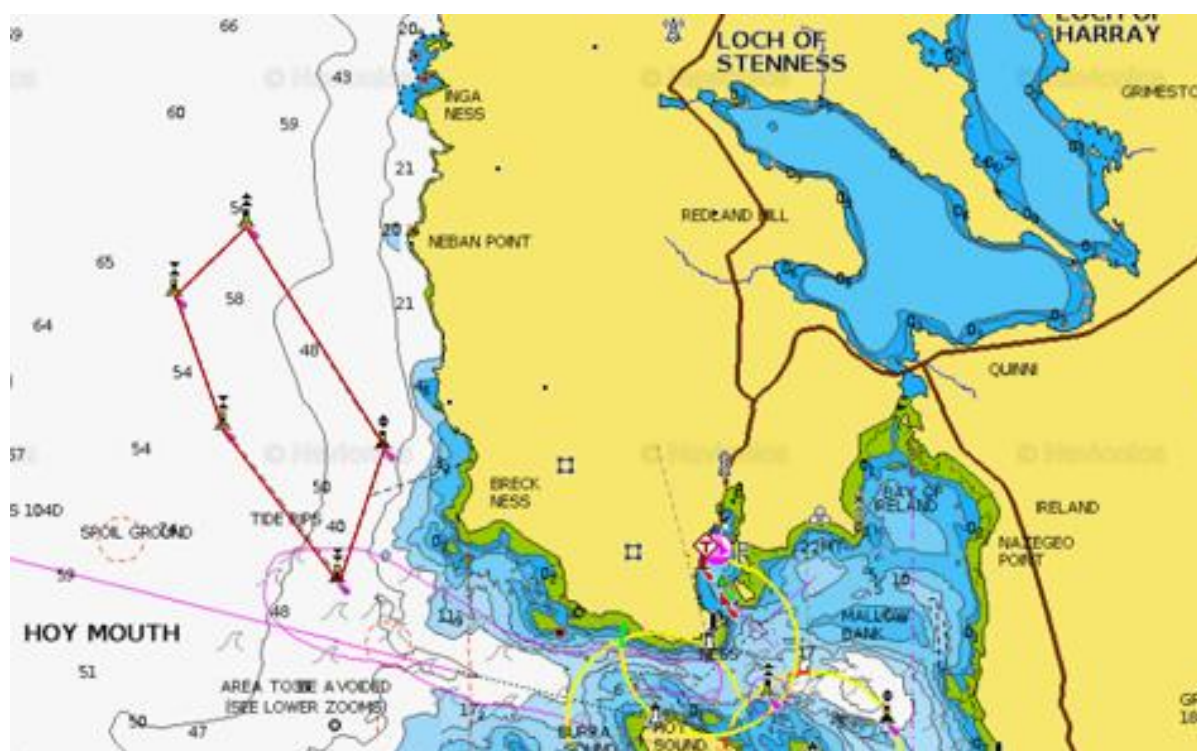

Figure 1: Indication of the Billia Croo wave energy test site¹

¹ Chart from Navionics: https://webapp.navionics.com/?lang=en#boating@9&key=%7Df%7DfJb_%60S [09.03.2018]

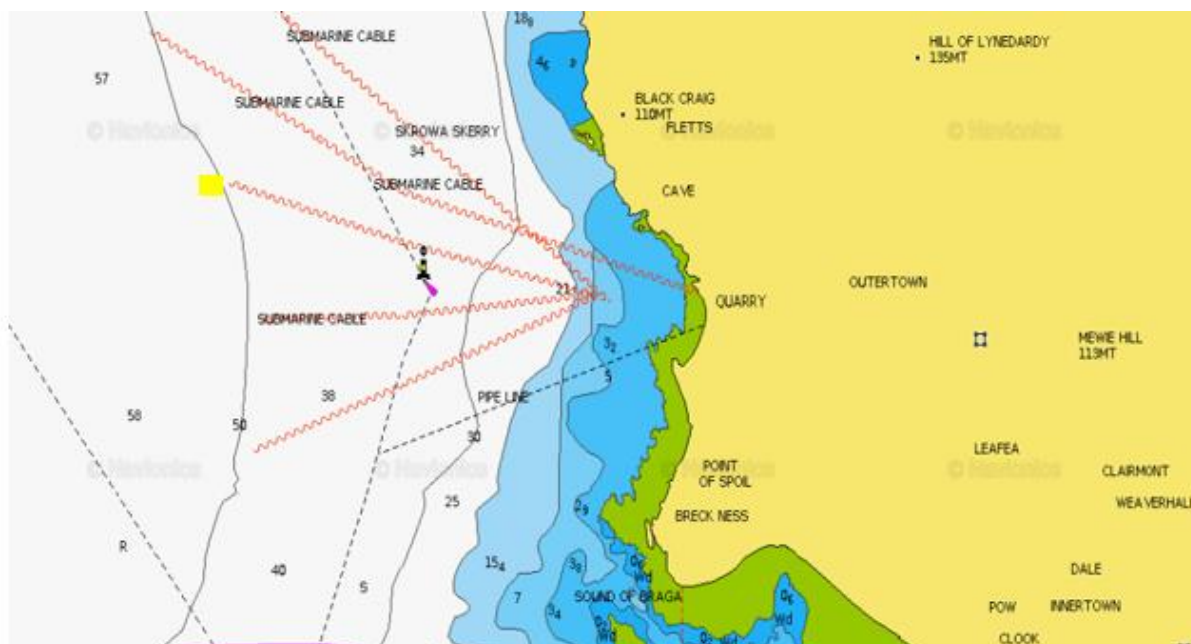

Figure 2: Indication of the deployment area of the Laminaria WEC¹

2.5 Technical summary of the project

The WEC will be built in Zeebrugge, Belgium and towed to the UK by a multi-cat vessel. It will be fully assembled in Belgium and connected to a variable buoyancy gravity base anchor in Zeebrugge.

The WEC can be installed in sea states of up to 2 m significant wave height (H_s) and when weather windows allow the installation, the WEC will be towed by the multi-cat vessel to the deployment location in berth two at Billia Croo. When the deployment position is reached, the chambers of the anchor will be filled slowly with water to decrease the WEC in position until the main floater will be in contact with the water. The chambers will be either filled completely with air or water to be able to regulate the buoyancy and to ensure a safe and steady submergence of the anchor. During the submergence of the anchor, the mooring lines of the WEC will be off-spooled and the installation process will be fulfilled when the anchor is successfully submerged and steady located at the seabed.

Afterwards, the main floater will be submerged to a water depth of 17.2 m by on-spooling of the mooring lines. This position allows the commission phase of the WEC in which the safety features will be tested. The movement of the WEC and the loads on the mooring lines and main floater will be identified and compared to the designed / expected movements and loads during this state of submergence. Additionally, the thermal, mechanical and electrical properties of the PTO systems will be identified and compared with the previously defined threshold. After the identification of the safety system of each individual part, the failure algorithms will be tested to ensure a correct behaviour of the WEC. With a successful testing of the safety measures, the main hull will be gradually exposed to higher wave energy by decreasing the submergence. The

height adaptation of the WEC will be tested and the WEC will be released for energy capture and electricity production.

There is no planned maintenance scheduled, but the WEC will be recovered several times during the deployment period. Due to the solution with the submergible anchor, the recovery principle will be the same method used for the decommissioning of the WEC at the end of the deployment period at EMEC. Before each recovery will take place, a video survey of the whole WEC and parts of the seabed will be conducted. After the recovery of the WEC, it will be towed by a multi-cat vessel towards the port of Lyness. These periods will be used for any occurring optimisations of the WEC. The WEC will be re-installed using the same principle as during the instalment phase.

The monitoring of the WEC and the potential interactions with the surrounding marine environment will include noise, camera, temperature and water ingress monitoring.

3 Environmental Description

There are various sources of information available regarding the environmental conditions at the Billia Croo test site. These include:

- Billia Croo Environmental Description (which encompasses wave and tidal resource data, geological data, weather information, seabed surveys, and environmental statement)
- Billia Croo Environmental Sensitivity Table
- Billia Croo Acoustic Characterisation
- Data from EMEC's monitoring projects

The baseline characterisation of the site has been reported in EMEC's environmental description, which has been used to assess the potential environmental impacts against.

The following summarises the receptors present at the Billia Croo test site that are relevant to Laminaria project.

3.1 Benthos

The infralittoral zone (lowest zone exposed only by low tides) of the area mainly consists of exposed bedrock whereas, the beginning of the circalittoral zone (zone which does not get exposed due to tidal movement) was identified to be exposed bedrock with a layer of sand and some boulders on top. With increasing depth from the shoreline, surveys have indicated a transition from bedrock to broken/stone to a seabed dominated by sediment. In water depths of around 40 m to 50 m, at test berth 2, the exposed bedrock is replaced by fine sand. The fine sand is interspersed with boulders and stones. Bedrock outcrops also occur within this area.

The species occurring in water depth greater than 45 m are infaunal polychaetes, nematodes and amphipods. Biotopes from *Flustra foliacea* are characteristic for the offshore sediment zone.

3.2 Plankton

As with typical northern British coastal waters, a higher proportion of intermediate and northern/boreal species are anticipated to be present at Billia Croo. Algal blooms in March through to May bring mainly diatom, followed by dinoflagellates during May to August.

It is typical for there to be a second algal bloom in early autumn and phytoplankton numbers tend to decline through winter.

Due to the increase in food sources, after each algal bloom there is an increase in copepod numbers and other zooplankton (e.g. ctenophores, hydromedusea, amphipods).

3.3 Fish and shellfish

Typical finfish species present at Billia Croo include:

- saithe (*Pollachius virens*);
- pollack (*Pollachius pollachius*); and
- ling (*Molva molva*).

Other gadoid species (including cod (*Gadus morhua*)) appear in Orkney waters during the summer months, Whiting (*Merlangius merlangus*) and haddock (*Melanogrammus aeglefinus*) tend to appear in larger shoals during late summer and autumn.

There are spawning and nursery areas for herring, sandeel, lemon sole, saithe and sprat within the Orkney Islands archipelago. Herring (*Clupea harengus*) and mackerel (*Scomber scombrus*) may transit through the site during their migratory passage. Herring are likely to be present in early summer whereas mackerel may be present in summer and autumn months. Other species that may be present at the site include:

- monkfish (*Lophius piscatorius*);
- conger eels (*Conger conger*); and
- gurnard (*Triglidae*).

In terms of shellfish present at Billia Croo, there are several species including:

- lobster (*Homarus gammarus*)

- brown crab (*Cancer pagurus*)
- velvet crab (*Necora puber*)
- shrimp (*Nephrops norvegicus*)

3.4 Birds

There are nationally and internationally important bird colonies located across Orkney’s coastlines. The sea cliffs around Billia Croo are inhabited by breeding numbers of Arctic skuas, great skuas and Arctic terns. Guillemots and kittiwakes are also expected to reside in nearby colonies. Highest numbers of these species would be expected between April and September.

Between 2009 and 2015, onshore wildlife observations were recorded from a vantage point overlooking the site. The following table provides a summary of bird species observed at the site.

Table 4: Bird species observed at the Billia Croo test site

Bird Species	Jan	Feb	Mar	Apr	May	Jun	Jul	Aug	Sep	Oct	Nov	Dec
Arctic skua												
Arctic tern												
Atlantic puffin												
Black guillemot												
Black scoter												
Black-legged kittiwake												
Common eider												
Common guillemot												
Eurasian wigeon												
European shag												
European storm-petrel												
Great black-backed gull												
Great northern diver												
Great skua												
Greylag goose												
Grey phalarope												
Herring gull												
Iceland gull												
Leach’s storm-petrel												
Little auk												
Long-tailed duck												
Manx shearwater												
Mew gull												
Northern fulmar												
Northern gannet												
Pink-footed goose												
Pomarine skua												
Razorbill												

Red-throated diver												
Velvet scoter												

^TLight grey – infrequent observations; dark grey – clear seasonality in observation; no shading across entire year – infrequent and no clear seasonality

Certain bird species observed within the Billia Croo test site, are listed under Annex I of the EU Birds Directive. Additionally, the site is in close proximity to several Special Protected Areas², which suggests that the project may have the potential to interact with qualifying features of the SPAs. In addition, Sites of Special Scientific Interest (SSSIs) have been designated nearby as they support nationally important colonies of breeding seabirds. Chapter 3.6 provides further details of the SPAs and SSSIs in close proximity to the test site.

3.5 Marine mammals

Harbour porpoises regularly feed in the area around Orkney mostly between April and September. Additionally, Minke whales, Risso’s dolphin, killer whales and pilot whales have been observed in the offshore area around Billia Croo. However, there are not believed to be any resident cetacean populations located close to the test area.

During the wildlife observations at the test site, a wide variety of marine mammals were observed; the most frequently recorded species of cetacean is harbour porpoise. Grey seals are more frequently observed in comparison to harbour seal, however, seals numbers are dramatically lower compared to other sites around Orkney.

Basking sharks have been observed at the site, however their presence does appear to be infrequent suggesting that they are transiting through the site. European otters have been observed at the site, however the area of observation does not stretch inshore, where it would more regular observation would be expected.

A summary of the marine mammals sighted at Billia Croo throughout the duration of the observation programme has been provided in the following table. Where there have been a sufficient number of observations, species seasonality can be gained.

Table 5: Marine mammal species (inc. basking shark) observed at Billia Croo

Marine Mammal Species	Jan	Feb	Mar	Apr	May	Jun	Jul	Aug	Sep	Oct	Nov	Dec
Bottlenose dolphin												
Common dolphin												
Harbour porpoise												
Humpback whale												
Killer whale												

² Special Protection Areas (SPAs) are strictly protected sites classified in accordance with Article 4 of the EC Birds Directive, which came into force in April 1979. They are classified for rare and vulnerable birds (as listed on Annex I of the Directive), and for regularly occurring migratory species.

Marine Mammal Species	Jan	Feb	Mar	Apr	May	Jun	Jul	Aug	Sep	Oct	Nov	Dec
Long-finned pilot whale												
Minke whale												
Pilot whale												
Risso's dolphin												
Short-beaked common dolphin												
Sperm whale												
White beaked dolphin												
White sided dolphin												
Grey seal												
Harbour seal												
European otter												
Basking shark												

Light grey – infrequent observations; dark grey – clear seasonality in observation; no shading across entire year – infrequent and no clear seasonality

Note all cetacean species that occur in Scottish waters are listed under Annex IV of the Habitats Directive, and as species of European Community interest are afforded protection as European Protected Species (EPS). All marine mammals (including European otter) and basking shark are listed as Priority Marine Features.

The harbour seal population in Orkney has been declining over the last decade and therefore the Special Areas of Conservation within the Orkney region that have harbour seals as a qualifying feature are in unfavourable condition. Seal haul-out sites have been designated throughout Scotland to provide additional protection for seals from harassment. Although there are no designated seal haul-out sites on the west coast of Orkney, when vessels are transiting to and from site they may come in close proximity to designated sites. The haul-out sites closest to the test site are Selkirk (north Hoy) and Bay of Ireland (south west Orkney Mainland).

3.6 Protected sites

There are a number of sites protected at the European and national level within close proximity to the Billia Croo test site. Information regarding the relevant sites is provided in the following table including their respective qualifying or priority feature.

Table 6: Designated sites located in close proximity to the Billia Croo test site

Designation	Site Name	Feature
Special Protection Area	Hoy	Arctic skua (breeding); Fulmar (breeding); Great black-backed gull (breeding); Great skua (breeding); Guillemot (breeding); Kittiwake (breeding); Peregrine (breeding); Puffin (breeding); Red-

Designation	Site Name	Feature
		throated diver (breeding); seabird assemblage (breeding).
Special Protection Area	Orkney Mainland Moors	Hen harrier (breeding and non-breeding); Red-throated diver (breeding); Short-eared owl (breeding).
Special Area of Conservation	Loch of Stenness	Marine lagoon (inc. marine mammals)
Special Area of Conservation	Faray and Holm of Faray	Grey seal
Special Area of Conservation	Sanday	Harbour seal; intertidal mudflats and sandflats; reefs; subtidal sandbanks.
National Scenic Area	Hoy and West Mainland	<ul style="list-style-type: none"> • A palimpsest of geology, topography, archaeology and land use • An archaeological landscape of World Heritage Status • The spectacular coastal scenery • Sandstone and flagstone as an essence of Orkney • A long-settled and productive land and sea • The contrast between the fertile farmland and the unimproved moorland • A landscape of contrasting curves and lines • Land and water in constantly changing combinations under the open sky • The high hills of Hoy • The townscape of Stromness, its setting and its link with the sea • The traditional buildings and crofting patterns of Rackwick
Marine Protected Area	North-west Orkney	Sandeels; marine geomorphology of the Scottish Shelf Seabed
Sites of Special Scientific Interest	Stromness Heaths and Coast	Coastal geomorphology of Scotland; maritime cliff; non-marine Devonian; subalpine dry heath
Sites of Special Scientific Interest	Hoy	Arctic skua (breeding); fulmar (breeding); great black-backed gull (breeding); Great skua (breeding); Guillemot (breeding); Peregrine (breeding); Red-throated diver (breeding); seabird colony (breeding); breeding bird assemblage; upland assemblage; blanket bog; coast geomorphology of Scotland; dystrophic loch; Non-marine Devonian; Old red sandstone igneous; quaternary of Scotland; upland oak woodland.
Sites of Special Scientific Interest	Lochs of Harray and Stenness	Goldeneye (non-breeding); Pochard (non-breeding); Scaup (non-breeding); Tufted duck (non-breeding); Caddisfly; Eutrophic loch; freshwater nerite snail; saline lagoon.
Sites of Special Scientific Interest	Orphir and Stenness Hills	Hen harrier (breeding); breeding bird assemblage; upland assemblage.

The EMEC test site is located partly inside the National Scenic Area which is protecting extraordinary landscapes of Scotland.

Recently, there has also been a proposed Special Protected Area allocated which is near to the Billia Croo test site, Scapa Flow pSPA. This site has been proposed due to its qualifying bird species which include: great northern diver; red-throated diver; black-throated diver; and, Slavonian grebe. The site also supports migratory populations of European shag; common eider; long-tailed duck; common goldeneye; and red-breasted merganser.

4 Project Description

Laminaria NV will install a full-scale wave energy converter (200 kW rated power) at the wave energy test site Billia Croo at EMEC in August 2018. A brief summary about project details is given in part 9 of this PEMP and more detailed information can be found in the *Project Information Summary* of Laminaria.

4.1 WEC Description

As a result of the horizontal movement in the water, the WEC is subjected to a tilting and translating motion. These motions are transferred through the mooring lines to the PTO chambers located at the bottom of the WEC. Each PTO chamber consists of a drum-system, a gearbox, an electrical motor and an asynchronous generator fixed to a main shaft.

The unique concept of the Laminaria WEC is the storm protection system which enables the WEC to produce continuous electricity even during severe environmental conditions. Loads acting on the Laminaria WEC and the mooring lines will be measured by load cells. In case of an exceeding of the pre-defined load threshold, the WEC will activate the storm protection system and increases the submergence of the WEC to lower energy parts of the water until the nominal load threshold is reached again. This feature enables the Laminaria WEC to produce a continuous and steady electricity production. With an identification of an undercut of the load threshold, the submergence of the WEC will decrease step by step into higher energy parts of the water.

There is one storm protection system installed in each PTO chamber of the WEC. The storm protection system consists of the gearbox and the electric motor. In normal operating conditions, the two drums per shaft are fixed relative to each other. In storm protection mode, one of the drums is rotated relative to the other and decreases the total length of the mooring lines and thereby altering the position of the WEC in the water column. Therefore, the impact of extreme wave energy loads is reduced. The Laminaria WEC remains operational during storm conditions in storm survival mode

and can maintain electrical generation. During small sea states with typical waves of 3 m Hs, the WEC can protrude the sea surface by up to 1 m.

The WEC is connected by four individual mooring lines to a gravity base anchor. The mooring lines are configured in a W-shaped layout (consisting of two V-shaped layouts) as indicated in Figure 3. The motion of the WEC gives a reeling out of the mooring lines of one V-shaped part of the mooring line layout. This leads to an increase of the same V-shaped part and a compensatory reeling in and shortening of the other V-shaped part of the mooring line layout.

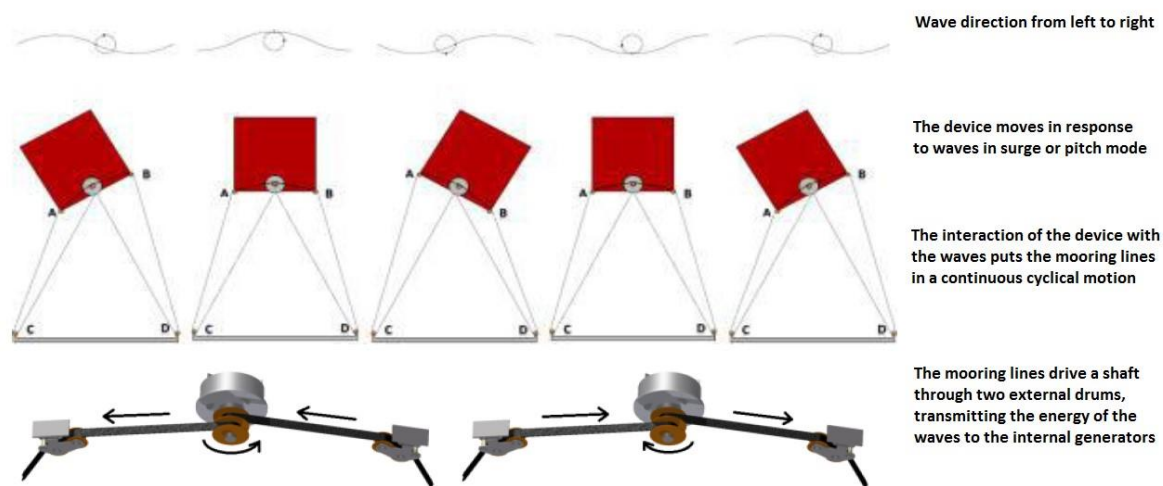

Figure 3: Schematic sketch of the WEC movement (pitch), the changing mooring line layout and the movement of the mooring lines on the drum-system

The Laminaria WEC will re-use the umbilical connected to the subsea cable of berth two for the electric connection of the WEC to the local grid. The connection between the umbilical and the WEC is made by a cable terminator.

The key dimensions of the Laminaria WEC are shown in table below.

Table 7: Main Dimensions of the Laminaria WEC

Part of the WEC	Dimensions
Overall height of the WEC	13.30 m
Overall width of the WEC	11.80 m
Height of the fins	11.80 m
Width of the fins	0.5 m
External radius of the hull	7 m
Centre of Gravity	6.35 m
Estimated mass of the WEC	250 t
Anchor footprint	26.5 m x 26.5 m

Anchor height	4 m
Estimates anchor mass	2,200 t

The following pictures will give a better understanding of the WEC design and the assembly during the towing.

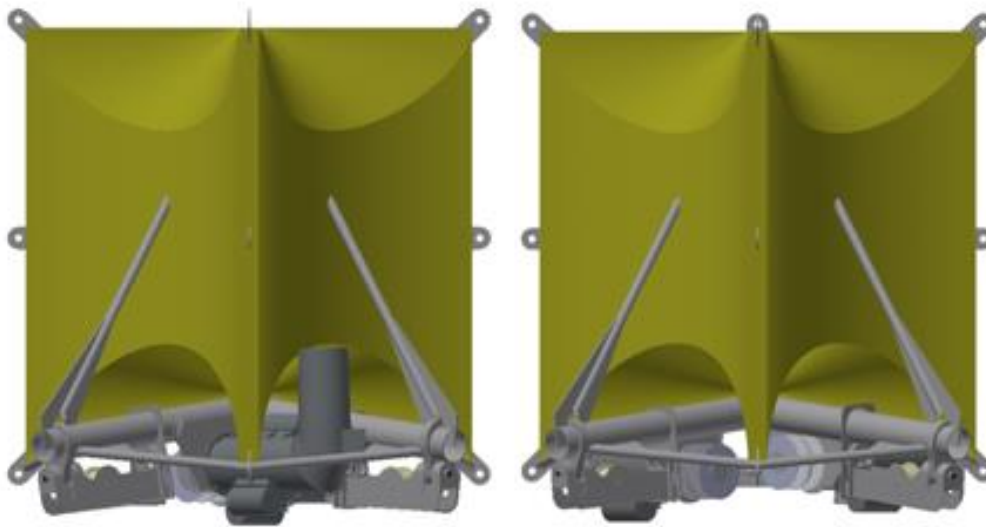

Figure 4: Drawing of the main floater with attached PTO chambers

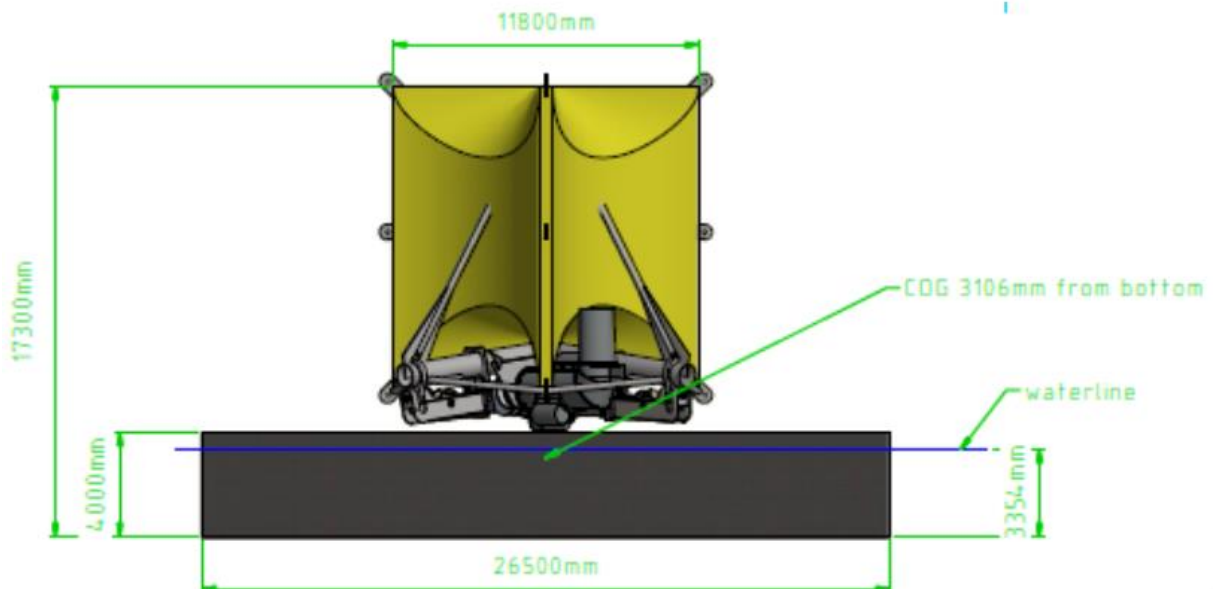

Figure 5: Drawing of the WEC assembly during the towing

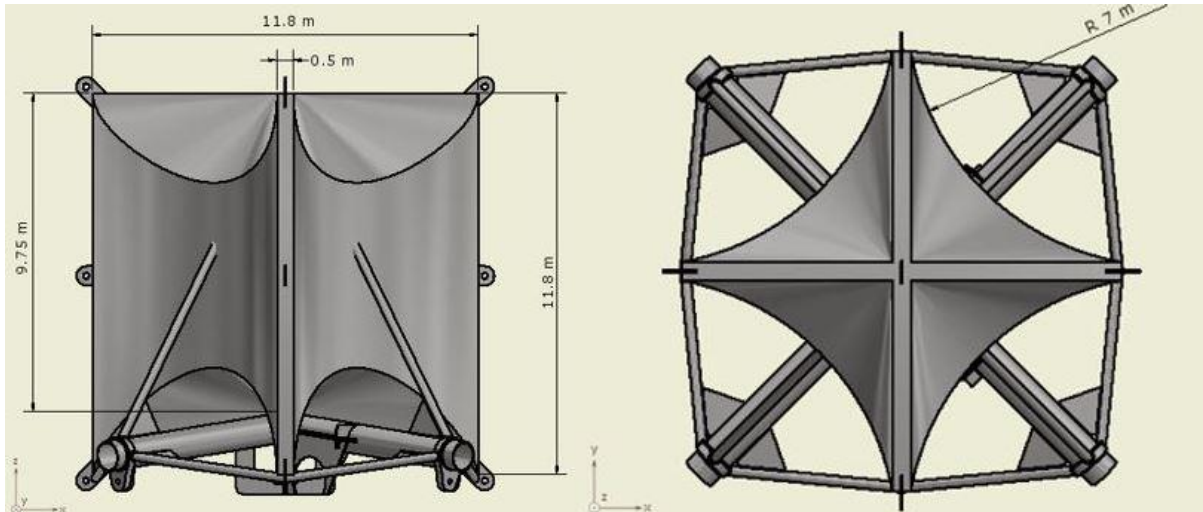

Figure 6: Sketch of the Laminaria WEC



Figure 7: Front and side view of the Laminaria WEC (drawing)

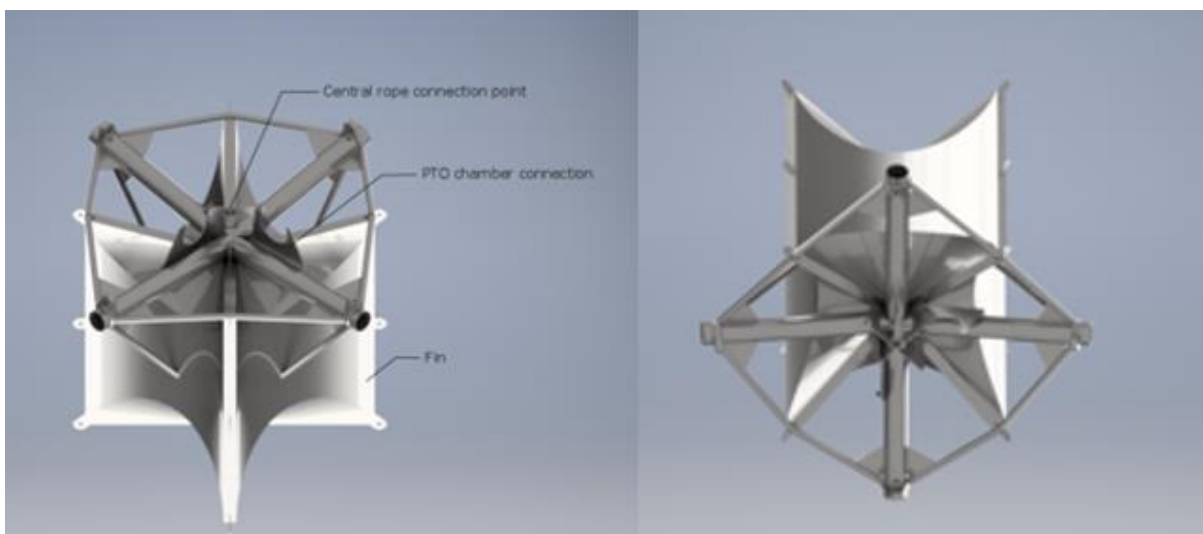

Figure 8: Bottom view of the Laminaria WEC

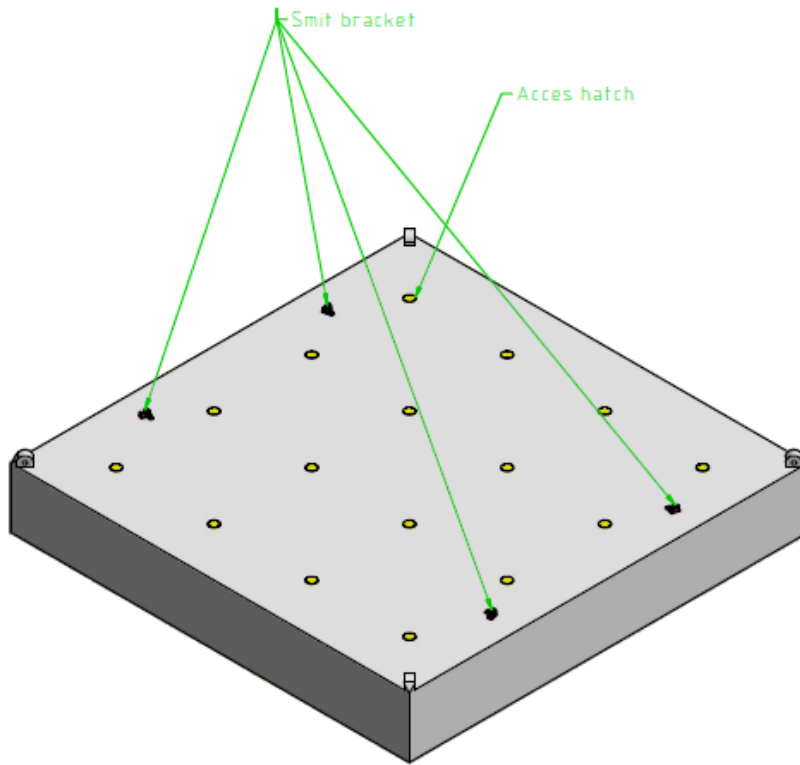

Figure 9: Drawing of the gravity base anchor

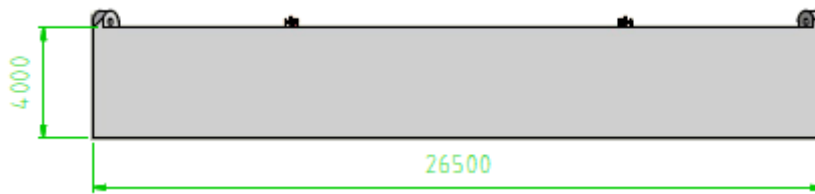

Figure 10: Drawing of the gravity base anchor (front view)

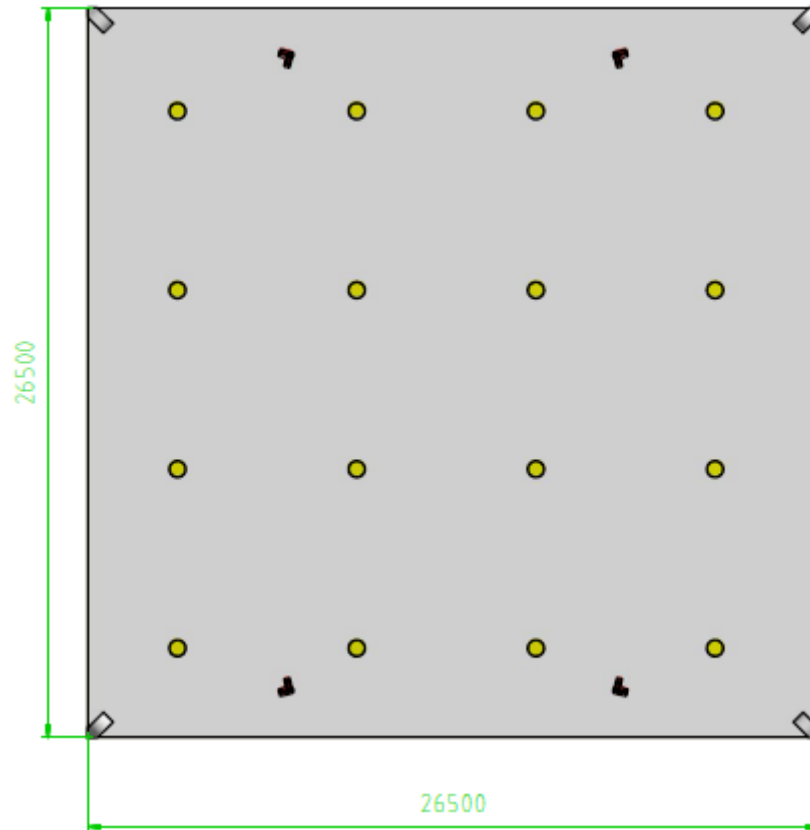

Figure 11. Drawing of the gravity base anchor (top view)

4.2 WEC Installation

The main floater will be connected to a concrete gravity base anchor which is variable in buoyancy. The whole structure will be towed by a multi-cat vessel to the deployment site at EMEC. Chambers, which are included in the anchor, will be filled slowly with water to decrease the anchor further into the water until the main floater is slightly submerged. Thereby, the chambers are either filled with water or air which enables the anchor to have a stable and variable buoyancy, which will ensure a safe and steady submergence. The positive buoyancy of the main floater will stabilise the structure. The mooring lines of the WEC will be spooled off to release the anchor to the seabed to provide station keeping of the WEC while preventing it from drifting. After the successful installation of the gravity base anchor, the mooring lines will on-spool again to submerge the main floater and to test the safety features of the WEC (commissioning phase). More information of the WEC installation can be found in the *Project Information Summary*.

4.3 WEC maintenance

During the one-year deployment period at EMEC, no planned maintenance is scheduled. However, the WEC will be recovered and re-installed several times during the testing period. Before the recovery of the WEC, a video survey will be conducted to evaluate the main floater, anchor and surrounding seabed. A multi-cat vessel will

tow the WEC to the harbour of Lyness and potential re-alignments and small repairs will be conducted. The variable buoyancy gravity base anchor provides a base on which potential works can be conducted and which eliminates the need of a crane and the removal of the WEC from the water.

4.4 WEC decommissioning

The decommissioning of the WEC will be conducted in the reverse order of the installation process. The marker buoy connected to the marine air hose will be recovered by a small work vessel and the end will be connected to an air compressor located on the work vessel. Air will be filled in the chambers to increase the buoyancy to close to zero. This process allows the regulation of the buoyancy of the anchor and surfaces the anchor step by step. The mooring lines of the WEC will be spooled on to avoid slack and to provide assistance in recovering the gravity base anchor. After the full surfacing, the towing lines of the multi-cat vessel will be connected to the smith brackets of the anchor and the WEC will be towed to the harbor of Lyness or the next deployment location. More information on the WEC decommissioning can be found in the *Project Information Summary* and the *Decommissioning Programme*.

4.5 Protection of the WEC

The following WEC protection measures will be in place during the deployment period at EMEC:

- Corrosion protection / Antifouling protection: the WEC will be protected against corrosion using anodes and anti-corrosion coating. No anti-biofouling coating will be used, due to the continuous recoveries of the WEC. Additional substances which can be used can still have negative effect on the surrounding marine environment and Laminaria tries to keep the impacts as minor as possible.
- WEC Marking: After consultation with the Northern Lighthouse Board (NLB), the Laminaria WEC will not be lighted during the deployment period at EMEC. However, Laminaria will install retro-reflective tape or panels at the top part of the main floater and the main floater will be painted in yellow for maximum daytime conspicuity, in line with IALA Recommendation O-139.
- Electrical System: Due to the mostly submerged position, the Laminaria WEC is not equipped with lightning protection. The voltage of the generated electricity which is fed into the grid is 6.6 kV.
- Requirements: The WEC is using 50 kV from the grid to operate the height adaptation of the storm protection system.
- Communication Systems: The fibre optics in the subsea cable of EMEC will be used for communication purposes.

5 Environmental Appraisal Summary

5.1 Impact Identification and Assessment

During the different stages of the WEC deployment, there will be varying potential environmental impacts based on the WEC design and the marine operations.

As outlined in the Section 2.3, a comprehensive assessment of the potential environmental impacts has been undertaken. The full details from the assessment are provided in Annex 1. A summarised list of the potential key environmental impact pathways and their evaluated significance, is provided in the below table

Table 8: Potential key environmental impact pathways

Identified activity	Potential impact pathway	Impact Significance
WEC presence	Displacement of habitat	Minor
	Change in distribution of marine species	Minor
	Hazard to navigation	Moderate
Underwater noise due to the WEC parts (motors, electronics)	Disturbing of pelagic species	Minor
	Change in wildlife distribution	Minor
Underwater noise due to the presence of the WEC	Disturbing of pelagic habitats	Minor
	Effects on wildlife distribution	Minor
Underwater vibrations due to the WEC	Disturbance to pelagic species and habitats	Minor
	Effects on wildlife distribution	Minor
Underwater noise due to increased vessel activity	Noise and vibration resulting in disturbance to wildlife	Moderate
	Disturbances to pelagic habitats	Moderate
Anchor system	Disturbing/Damaging/Destroying of seabed habitat and ecosystems	Moderate
Mooring system	Entanglement with marine megafauna	Moderate

The following impact pathways have been identified to have a moderate impact on the environment:

- Hazard to navigation due to WEC presence: the WEC represents an additional structure in the water which could result in a hazard to navigation. The deployment of the WEC will take place within an established wave energy test

site. Additionally, Laminaria will release a Notice to Mariners to inform all marine stakeholders of the location of the WEC, the installation, operation and decommissioning works and any maintenance or recovery phases. As mentioned above, the Laminaria WEC will be not lit but marked with retro-reflective tape or panels and the main floater will be painted in yellow. Therefore, the WEC will be marked in accordance with NLB advice, to reduce risks of the WEC becoming a marine hazard. Further details regarding this impact pathways are provided in the *Navigational Risk Assessment Annex*.

- Disturbance to wildlife due to underwater noise and vibration of increased vessel traffic: Due to the active wave energy test site of Billia Croo, the marine vessel traffic is already increased with a peak during the installation, maintenance and decommissioning periods. The vessels required by Laminaria will use indicated marine transport routes as much as possible to reduce the additional noise and vibration in the area. The increased vessel traffic will be temporary in nature. Due to smart vessel management, the time of maintenance vessels at site will be kept to a minimum.
- Disturbance to pelagic habitats due to underwater noise of increased vessel traffic: The underwater noise of the vessels will be kept to a minimum due to a smart vessel management plan of Laminaria and reduced time at site. The noise disturbance will be temporary in nature with a peak during installation, maintenance and decommissioning phases.
- Disturbing/Damaging/Destroying of seabed habitats and ecosystem due to the anchor system: The presence of the gravity base anchor will disturb the seabed habitats during the deployment period of the WEC. The WEC will be micro-sited in berth two to reduce the potential impact on the seabed habitat and the ecosystem. The effects of the anchor will be investigated during the regularly conducted video surveys.
- Entanglement of marine megafauna with the mooring system: The four mooring lines of the WEC will be kept in tension at all times to decrease the risks of entanglement with marine megafauna. Additionally, a live feed of a camera installed at the bottom of the WEC indicates potential interaction of marine species with the drum system and will be used for research purposes to evaluate potential measures to decrease the entanglement risks of the WEC for future deployments.

Following implementation of the mitigation and monitoring measures, the significance of the impact pathways was reassessed. The following activities could lead to minor residual impacts on the environment:

- Displacement of habitat due to the presence of the WEC: There are no significant changes in the habitats anticipated, but the potential environmental effect cannot be mitigated completely. Environmental monitoring will be in place to identify significant environmental changes.

- Change in distribution due to the presence of the WEC: The WEC may attract marine species like fish due to the potential shelter and occurring marine growth. Increased presence of fish may increase the presence of predators such as marine mammals and may increase the risk of entanglement. A camera mounted at the bottom of the WEC will provide a live-feed which will give information about potential increased marine species presence at the WEC.
- Disturbing of pelagic species and changes in wildlife distribution due to underwater noise and vibration of parts of the WEC (motors, electronics): The acoustic signature of the WEC is estimated to be low compared to the overall background noise. Therefore, the noise is not expected to propagate to a distance that it could cause significant displacement effects. If additional funding is found³, an acoustic survey will take place during the deployment period at EMEC.
- Disturbing of pelagic habitats and distribution effects of marine wildlife due to underwater noise regarding the presence of the WEC: It is estimated that the major noise contribution will be the interaction of the WEC with the waves. The sound is expected to increase with increased roughness of environmental conditions, but the WEC will be expected to submerge further during rougher sea states.
- Disturbance to pelagic species and habitats and effects on wildlife distribution due to underwater vibrations of the WEC: The vibrations of the WEC are not expected to be a significant impact on the surrounding environment.
- Disturbance to wildlife and pelagic habitats due to underwater noise of increased vessel activity: Operational planning will reduce the time needed at sea. The noise disturbance of marine vessels required by Laminaria will be only temporary in nature. It is expected that species are avoiding the area during the periods of maintenance and the corresponding higher noise level.
- Disturbing/Damaging/Destroying of seabed habitat and ecosystems due to the anchor: Micro-siting in the test berth will be conducted to decrease the level of interaction as much as possible. Seabed surveys will be included during the deployment period at EMEC to identify the level of impact. A loss of seabed communities will be limited to the footprint of the anchor.
- Entanglement with marine megafauna due to the mooring system: The mooring lines will be taught at all times to decrease the level of risk for entanglement of marine species. Loadcells mounted on the WEC will ensure this also during stormy conditions.

5.2 Mitigation and Management

The mitigation measures to reduce the identified risks in Table 8 are stated in Annex 2.

³ Please note a proposal has been submitted to the European Commission which includes this proposed monitoring measure.

Additional to the mitigation measures for the reduction of environmental effects during the deployment period, Laminaria was aware of potential negative environmental effects of the WEC and included these into the overall design.

The WEC construction was designed to be installed and decommissioned within the smallest amount of time needed to reduce costs of maintenance vessels, but also to reduce the negative effects on the surrounding environment due to increased vessel traffic or noise occurrence. Due to the simple design of the WEC, the instalment can be obtained during one day which reduces the on-site time drastically. Besides the fast installation, only one multi-cat vessel and a small work boat will be needed. Regarding the transportation, simple towing will be used, which is one of the factors in reducing vessel requirements.

The anchor design of the WEC is designed as variable buoyancy gravity base anchor. This concept does not require any drilling or dredging of seabed material for the installation and reduces the impact on the seabed drastically.

As minor as possible moving parts will be embedded in lubricant to ensure functionality. There will be two individual seals to protect any lubricant from leaking into the surrounding water. Additional, leakage detection is implemented after the first seal to ensure continuous protection and to provide time for maintenance strategies. The lubricant used by Laminaria is Offshore environmental oil (HDEO EP & EO220) to further decrease the risks for the surrounding environment in case of a leakage.

After the deployment period of the Laminaria WEC, the WEC will be re-used and deployed in follow up projects.

5.3 Commitments Register

All monitoring and mitigation measures have been included in the Commitments register (see Annex 3) alongside the mitigations and recommendations produced during the *Navigational Risk Assessment Annex*. All commitments will be tracked on the Commitments Register and Laminaria will conduct monthly reviews of the register to ensure compliance.

5.4 Reporting Schedule

The Environmental Monitoring Plan part of this document will be continually updated to ensure the contents remain in line with planned mitigation, management and monitoring measures. The Plan is a live document, therefore the at Laminaria WEC project progresses and any new mitigation and monitoring methods, that offer a greater opportunity for Laminaria to reduce their potential impact or increase understanding, will be considered.

Laminaria intend to produce Environmental Monitoring Reports (EMRs) at various stages along the project's lifespan. The following table provides an indication of the intended reporting schedule including updates to the Plan and production of the EMRs.

Table 9: Reporting Schedule

Reporting schedule	Type of report
Post-consultation	The PEMP will be updated to include feedback from consultees and incorporate any necessary modifications. The PEMP will be recirculated to consultees.
6 weeks after device commissioning	Delivery of an Installation Environmental Monitoring Report.
6 months into testing	Review and update of the PEMP. Production of an Environmental Monitoring Report.
3 months prior to decommissioning works commencing	Reassessment of the PEMP in light of the upcoming decommissioning works and submission to relevant consultees. Depending on proximity to previous EMR, production of an Environmental Monitoring Report.
6 weeks after device decommissioning	Submission of Final Environmental Monitoring Report

Annex 1: Identification of potential impacts due to activities of the WEC, mitigation and management measures and residual impact significance

Identified activity	Potential impact pathway	Potential impact significance	Proposed management and mitigation measures	Residual impact significance	Comments
WEC presence	Change of currents	Negligible	Insignificant loss of the current speed, no severe effects on the marine wildlife are estimated to occur. No mitigation measures identified.	Negligible	
	Displacement of habitat	Minor	No significant change in habitats are anticipated. No mitigation measures have been identified.	Minor	
	Indirect changes to seabed	Negligible	The WEC will produce a shadow on seabed underneath, but the area of seabed impacted will be limited and no significant changes in the environmental conditions are expected. No mitigation measures identified.	Negligible	
	Changes in surface waves	Negligible	As the WEC extract energy from the waves, there is likely to be a localised reduction in wave energy in close proximity to the WEC. However the reduction is likely to be negligible and unlikely to result in any significant effects over and above the natural variation that takes place along such an exposed coastline. No significant negative effect on the surface waves is estimated to occur. No mitigation measures identified.	Negligible	

Identified activity	Potential impact pathway	Potential impact significance	Proposed management and mitigation measures	Residual impact significance	Comments
	Change in distribution	Minor	<p>The WEC may act as a fish aggregation WEC. Increased presence of fish may encourage predators such as marine birds and marine mammals to approach the WEC. Consequently, this may increase the risk on entanglement.</p> <p>A camera is mounted on the bottom of the WEC. Opportunistic monitoring may be allow a greater understanding the extent of fish aggregation.</p>	Minor	
	Hazard to navigation	Moderate	<p>The WEC will be mark and lit appropriately, in line with NLB recommendations.</p> <p>The WEC will be charted appropriate on admiralty charts.</p> <p>Notice to Mariners will be issued prior to marine operations onsite.</p>	Minor	Collision with the WEC due to small boats which are passing through the test area is possible, but appropriate measures will be taken to reduce the risk of such an event.
	Visual impact	Negligible	<p>As the WEC will be mainly submerged, it is not expected to cause any impact visually on the landscape and seascape.</p> <p>In addition, the WEC will be located in a designated wave test site alongside a number of other surface-piercing WECs.</p> <p>Visibility of WEC is limited to some nearby residences, walking and transport routes in the immediate vicinity.</p> <p>No mitigation measures have been identified.</p>	Negligible	
Underwater noise due to the WEC parts (motors, electronics)	Disturbing of pelagic species	Minor	<p>The acoustic signature produced by the WEC is estimated to be low compared to the background noise of the area.</p> <p>If additional funding is found, an acoustic survey using either static or drifting hydrophones will be sued to characterise the acoustic signature of the WEC.</p>	Minor	

Identified activity	Potential impact pathway	Potential impact significance	Proposed management and mitigation measures	Residual impact significance	Comments
	Change in wildlife distribution	Minor	<p>The acoustic signature produced by the WEC is estimated to be low compared to the background noise of the area.</p> <p>The noise produced by the WEC is not expected to propagate to such a distance to cause significant displacement effects.</p>	Minor	
Underwater noise due to the presence of the WEC	Disturbing of pelagic habitats	Minor	<p>Noise will occur due to the contact of the waves with the WEC and will increase with rougher sea conditions; it is expected that the background noise will also increase with rougher sea conditions, therefore no significant disturbance is estimated.</p> <p>No mitigation measures have been identified.</p>	Minor	
	Effects on wildlife distribution	Minor	<p>Noise will occur due to the contact of the waves with the WEC and will increase with rougher sea conditions; it is expected that the background noise will increase with rougher sea conditions as well and therefore, no significant disturbance is estimated.</p> <p>In rougher sea states, the WEC will submerge further and therefore, less energy exposure of waves will interact with the WEC which results in less underwater noise.</p> <p>No mitigation measures have been identified.</p>	Minor	
Underwater vibrations due to the WEC	Disturbance to pelagic species and habitats	Minor	<p>It is anticipated that vibrations will resonate from parts of the WEC and/or mooring lines, however the vibrations are not estimated to be significant.</p> <p>No mitigation measures have been identified.</p>	Minor	
	Effects on wildlife distribution	Minor	<p>Vibrations produced by the WEC and mooring system are not expected to be significant nor resonate far in the surrounding environment.</p> <p>No mitigation measure have been identified.</p>	Minor	

Identified activity	Potential impact pathway	Potential impact significance	Proposed management and mitigation measures	Residual impact significance	Comments
Underwater noise due to increased vessel activity	Noise and vibration resulting in disturbance to wildlife	Moderate	Operational planning will minimise sea time for workboats as far as practical. Vessels will adhere the Scottish Marine Wildlife Watching Code.	Minor	
	Disturbance to pelagic habitats	Moderate	As the WEC will be located in an operational test site, the site already experiences increased vessel traffic. The increased vessel traffic will be temporary in nature and typically occur during installation, infrequent maintenance, period removal/reinstallation and decommissioning. All vessels used in the project will meet MCA requirements and will be maintained to ensure highest efficiency.	Minor	Temporary disturbance could be possible, but it is expected that the species are avoiding the area during the periods of maintenance (and may be higher noise levels)
Presence of installation vessels	Disturbing of benthic communities	Minor	Vessel anchoring will be limited to when necessary. Design WEC and moorings to allow the use of small workboats.	Negligible	
Presence of maintenance vessels	Hazard to navigation	Minor	Notice to Mariners will be issued prior to marine operations onsite.	Negligible	
Anchor system	Scour	Minor	To reduce the extent of scour it is proposed to install weights or similar around the anchors to decreasing the effects of any potential scour.	Negligible	
	Disturbing/Damaging/Destroying of seabed habitat and ecosystems	Moderate	Conduct micro-siting in the test berth location, to select an area where limited damage may occur. Pre-installation, post-installation, pre-decommissioning and post-decommissioning seabed survey to assess level of impact on the seabed and to inspect the moorings. On decommissioning, anchors will be removed, as far as possible, in a single attempt so as to reduce disturbance.	Minor	It is expected that there will be a loss of seabed communities within the direct footprint of the anchoring system.

Identified activity	Potential impact pathway	Potential impact significance	Proposed management and mitigation measures	Residual impact significance	Comments
	Effect in wildlife distribution	Minor	Micro-siting will be conducted to select a deployment location where as limited damage as possible will occur. No significant disturbance of the wildlife distribution is expected.	Negligible	
Mooring system	Entanglement with marine megafauna	Moderate	Ensure mooring lines are taught on installation reducing the risk of entanglement. Autonomous load cells on mooring system to ensure system remains taught in stormy conditions.	Minor	

Annex 2: Monitoring and Mitigation Plan

1 Introduction

This document states the monitoring and mitigation measures identified by Laminaria during the one-year deployment period at EMEC as an annex to the *Project-Specific Environmental Report / Environmental Monitoring Plan*. This Annex will be updated throughout the project accordingly to support all necessary and identified potential environmental impacts.

2 Environmental Monitoring

During the deployment period at EMEC, monitoring will be conducted to identify potential environmental effects due to the presence, installation, operation and decommissioning of the Laminaria WEC. Included in the monitoring are:

- Noise monitoring: noise of the WEC will be measured with three microphones located in the main floater. The main source of the produced noise is estimated to be waves interacting with the WEC.
- Camera monitoring: a camera attached to the bottom of the WEC will monitor the drum systems and the upper part of the mooring lines to identify possible interactions or potential entanglement of marine species. The video will be a live-feed which enables immediate action in case of unforeseen events.
- Temperature monitoring: the temperature of the individual parts of the main floater will be measured to identify potential misalignments.
- Water ingress monitoring: monitoring of potential water ingress is in place to immediately identify water in the main floater or the PTO chambers.
- Load monitoring: loads cells will monitor the loads on the mooring lines and the main floater which will be used for the activation of the storm protection system. The load cells will ensure tension on all mooring lines at all times which reduces the risk of entanglement with marine species and snatch loads.
- Electrical connection monitoring: the electrical connection will be monitored to identify potential misalignments or damages.
- GPS monitoring: the WEC will be equipped with a GPS tracker to identify the position. This is an additional safety feature for the unlikely case of drifting or free floating of the WEC and can identify the WECs position in case of an emergency event.

Additionally, to the monitoring measures, the WEC will be connected to the *Supervisory, Control and Data Acquisition (SCADA)* system of EMEC to ensure a safe working environment. Laminaria will conduct video surveys of the complete WEC prior to each recovery of the WEC. These video surveys will be used to identify the level of scour at the anchor throughout the project and shortly after the installation of the WEC to identify potential mitigation measures.

3 Risk identification and evaluation

This paragraph states the potential environmental impacts identified during the environmental assessment process. A risk evaluation and mitigation strategy has been identified which resulted in the mitigation actions (Table 11) for the individual potential environmental impacts identified. Table 10 below provides a summary:

Table 10: Evaluation of risk and mitigation strategy of the potential environmental effects

Potential impact pathway	Strategy for evaluation of risk	Mitigation measure and optimisation strategy
<p>Disturbance to marine wildlife and other sea users from increased vessel traffic and associated activities at site and in transit areas during recovery and decommissioning (mainly due to presence and underwater noise of the marine vessels)</p>	<p>A Project-Specific Navigational Risk Assessment (NRA) will be completed (based on the EMEC site NRA) to include assessment of vessel traffic levels. This information will be used alongside projected vessel use associated with the project to determine the scale of increase in vessel activity.</p> <p>The identified risks will be agreed with Scottish Natural Heritage (SNH) prior to commencing the instalment of the WEC.</p> <p>A Habitat Regulations Appraisal (HRA) screening may be conducted by Marine Scotland based on the information provided by the project team but no significant interactions with Natura sites are anticipated given the simplicity of the WEC.</p> <p>All activities carried out will be consistent with MGN 543 and any other relevant legislation.</p>	<p>All activities will be completed in line with relevant MGNs and in consultation with Northern Lighthouse board (NLB), Maritime and Coastguard Agency (MCA) and local sea users. This will inform guidance on routes for vessels, procedures for Notification of Mariners, and marking of the site.</p> <p>The marine vessels required by Laminaria will use stated transition routes as much as possible.</p> <p>Initial site selection for the test site considered potential interactions with wildlife and other sea users.</p> <p>Laminaria will work with stakeholders to minimise disturbance in sensitive areas during sensitive times and will cooperate fully with any site monitoring programme requested by the regulator, SNH or EMEC.</p> <p>It is anticipated that minimal noise will be generated by vessels involved in operations and from the proposed installation methods.</p>

Potential impact pathway	Strategy for evaluation of risk	Mitigation measure and optimisation strategy
<p>Disruption to seabed communities during installation and decommissioning of the anchors.</p>	<p>The effects of the anchor installation and removal and any anchoring of support vessels have been identified during the environmental screening process</p>	<p>The test site has been selected to avoid sensitive habitats.</p> <p>During operational planning and operations, approaches will be taken that aim to limit seabed damage as far as practicable while still achieving the operational objectives. The exact deployment location of the WEC will take the different seabed habitats of berth 2 into account to identify the required area for the anchor installation in a part of the area in which the impacts on seabed habitats is the least. Implementation of an approved decommissioning plan and identification of the impacted seabed following anchor removal will verify the condition of the site upon cessation of the activities and removal of the associated equipment.</p>
<p>Change in local seascape through temporary increase in activity and incorporation of new structure into the local setting.</p>	<p>The effects, both positive and negative, of the temporary presence of the WEC, within the local setting will be identified during the deployment period.</p>	<p>Due to the environmental conditions at Billia Croo, the WEC will be mainly submerged during the deployment period. The usage of marine vessels and activities at sea will be kept to a minimum to minimise potential negative effects.</p> <p>The WEC will be installed within a designated test site and previous experiences showed that the WEC will generate a degree of positive interest within the local community and visitors as “point of interest”.</p>

Potential impact pathway	Strategy for evaluation of risk	Mitigation measure and optimisation strategy
<p>Effects on marine wildlife from the sustained presence and operation of the WEC and mooring system.</p>	<p>Where potential for significant impacts is anticipated, analysis will be undertaken to consider the consequences of such interactions. Special attention will be given to any habitats and species covered by the Habitats and Species Directive, including species associated away from designated sites.</p> <p>A Habitat Regulations Appraisal (HRA) screening will be conducted by Marine Scotland based on the information provided by the project team but no significant interactions with Natura sites are anticipated given the simplicity of the WEC.</p>	<p>It is anticipated that due to the design of the WEC, it will have a minimal noise signature and be very quiet mechanically. The most likely source of noise will be waves ‘slapping’ the hull structure of the WEC.</p> <p>The mooring lines of the WEC will always keep in tension, which decreases the risks of entanglement of marine wildlife. Interaction with the drum systems of the WEC could lead to a higher significance and therefore, a video feed of the drum systems will be available at all times.</p>
<p>Presence of WEC, mooring system and cable at sea creating additional navigational hazards for other sea users.</p>	<p>A project-specific annex to the Navigational Risk Assessment (NRA) will be completed (based on the EMEC site NRA) to include assessment of vessel traffic levels. This information will be used alongside projected vessel use within the project to determine the scale of increase in vessel activity.</p> <p>All activities carried out will be consistent with MGN 543 and any other relevant legislation.</p>	<p>All activities will be completed in line with relevant MGNs and in consultation with NLB and MCA and local sea users. This will inform guidance on routes for vessels, procedures for Notification of Mariners, and marking of the site if required.</p> <p>It should be noted that the WEC will be installed within a designated test site that has cardinal marker buoys marking the site perimeter.</p> <p>The mobilisation of marine vessels will keep to a minimum as much as possible, especially during hours of darkness. Additional, adequate lighting of the vessels will be ensured.</p>

4 Proposed Management and Mitigation measures

This paragraph gives an overview on the identified potential environmental impacts and the identified actions to trigger these potential negative impacts during the deployment period at EMEC. The mitigation strategies of Table 10 have been followed and Table 11 shows the proposed management and mitigation measures for each potential environmental impact of the Laminaria WEC.

Table 11: Mitigation and management measures

Identified activity	Prediction of potential impact	Proposed management and mitigation measures
WEC presence	Effect in wildlife distribution	There is no resident marine bird or cetacean population around Billia Croo
	Hazard to navigation (presence of WEC)	Proper marking and information to mariners that the WEC is deployed and the deployment location
	Visual impact	Due to the environmental conditions at Billia Croo, the WEC will be mainly submerged
Underwater noise due to the presence of the WEC	Disturbing of water column habitats	In rougher sea states, the WEC will submerge further and therefore, less energy exposure of waves will interact with the WEC which results in less underwater noise.
	Effects on wildlife distribution	In rougher sea states, the WEC will submerge further and therefore, less energy exposure of waves will interact with the WEC which results in less underwater noise.
Underwater noise due to increased vessel activity	Noise and vibration resulting in disturbances to wildlife	Operational planning will minimise sea time for workboats as far as practical. Vessels will adhere the Scottish Marine Wildlife Watching Code.

Identified activity	Prediction of potential impact	Proposed management and mitigation measures
	Disturbance to pelagic habitats	<p>As the WEC will be located in an operational test site, the site already experiences increased vessel traffic. The increased vessel traffic will be temporary in nature and typically occur during installation, infrequent maintenance, period removal / installation and decommissioning.</p> <p>All vessel used in the project will meet MCA requirements and will be maintained to ensure highest efficiency.</p>
Presence of installation vessels	Disturbing of benthic communities	<p>Vessel anchoring will be limited to when necessary.</p> <p>The design of the WEC and the moorings allow small workboats.</p>
Presence of maintenance vessels	Hazard to navigation (presence of WEC)	<p>Notice to Mariners will be issued prior to marine operations onsite.</p>
Anchor system	Scour	<p>To reduce the extent of scour it is proposed to install weights or similar around the anchor to decrease the effects of any potential scour.</p>
	Disturbing/Damaging/Destroying of seabed habitat and ecosystems	<p>Conduct micro-sitting in the test berth location to select an area where limited damage may occur.</p> <p>Pre-installation, post-installation, pre-decommissioning and post-decommissioning seabed survey to assess level of impact on the seabed and to inspect the moorings.</p> <p>On decommissioning, anchors will be removed, as far as possible, in a single attempt so as to reduce disturbance.</p>
	Effect in wildlife distribution	<p>Micro-sitting will be conducted to select a deployment location where as limited damage as possible will occur. No significant disturbance of the wildlife distribution is expected.</p>

Identified activity	Prediction of potential impact	Proposed management and mitigation measures
Mooring system	Entanglement with marine megafauna	<p>Mooring lines will be taught at all times during the installation, operation and decommissioning phase to reduce the risk of entanglement</p> <p>Autonomous load cells on mooring system to ensure system remains taught in stormy conditions.</p>

Annex 3: Commitments Register

The table below indicates the commitments to be fulfilled before, during and after the deployment period of the Laminaria WEC in order to ensure as least environmental risks as possible.

Table 12: Commitments Table

Issue	Commitment or action	Responsibility	Target completion date
Planning and Construction	Application and documentation submission to EMEC	Developer	April 2018
	Lighting and identification of the WEC to be agreed with NLB	Developer	April 2018
	Construction of the WEC after standards	Developer	June 2018
	Construction of the anchor after standards	Developer	June 2018
	Assembly of WEC and anchor in Zeebrugge (Belgium)	Developer	June 2018
	Site preparation	Marine Operator	June 2018
	Notice to Mariners	Developer	June 2018
	Towing of the WEC from Belgium to Orkney	Developer / Marine operator	July 2018
Installation	WEC and seabed survey (pre-installation)	Developer	June/July 2018
	Towing of the WEC to deployment location	Developer / Marine operator	August 2018
	Micro-siting of the WEC	Developer / Marine operator	August 2018
	Connection of the WEC with the electric subsea cable	Developer	August 2018
	WEC and seabed survey (post-installation)	Developer	August 2018
	Installations and recoveries will, whenever possible, be limited to daylight hours to avoid disturbances of marine mammals and birds	Developer / Marine operator	September 2019
WEC operation	Emergency Response Procedures will be establishment in line with EMEC ERP	Developer	May 2018
	Noise monitoring	Developer	September 2019
	Camera monitoring	Developer	September 2019
	Temperature monitoring	Developer	September 2019
	Water ingress monitoring	Developer	September 2019
	Load monitoring	Developer	September 2019

Issue	Commitment or action	Responsibility	Target completion date
	Electrical connection monitoring	Developer	September 2019
	GPS monitoring	Developer	September 2019
	WEC and seabed survey before recovery (each time)	Developer	September 2019
	Vessel adhere the Scottish Marine Wildlife Watching Code	Developer / Marine operator	September 2019
	Vessels will meet MCA requirements	Developer / Marine operator	September 2019
	Update of WEC recovery periods and unforeseen maintenance: Actualisation of Notice to Mariners (if applicable)	Developer	September 2019
Decommissioning	Pre-decommissioning survey	Developer	September 2019
	Decommissioning of the WEC	Developer	September 2019
	Towing of the WEC to the Lyness port	Developer / Marine operator	September 2019
	Post-decommissioning survey	Developer	September 2019
	Third Party Verification of decommissioning	Marine operator / Third party	October 2019
	Towing of the WEC to the next deployment location	Developer / Marine operator	October 2019