

The wave-powered adaptable monitoring package: hardware design, installation, and deployment

James B Joslin, Emma D Cotter, Paul G Murphy, Paul J Gibbs, Rob J Cavagnaro, Corey R Crisp, Andy R Stewart, Brian Polagye, Patrick S. Cross, Even Hjetland, Andrew Rocheleau, and Benjamin H Waters

Abstract— In October, 2018 the BOLT Lifesaver, a BOLT-class wave energy converter developed by Fred. Olsen Ltd., was deployed at the US Navy’s Wave Energy Test Site in Kane’ohe, Hawaii. The Lifesaver is an autonomous system, with no cable to shore. For a full year prior to the deployment, researchers and industry partners at the University of Washington, University of Hawaii, Fred. Olsen Ltd., Sea Engineering, and WiBotic Inc. collaborated on the development of an autonomous wave-powered environmental monitoring system. The Lifesaver was instrumented with an Adaptable Monitoring Package (AMP), as well as an on board control computer and power handling system. The AMP instrumentation suite included stereo-optical cameras, an acoustic camera, a multibeam sonar, two hydrophones, and a demonstration unit from WiBotic that could allow for wireless recharging of an underwater vehicle. At full power, the instrumentation and recharge system draws 600 W of power, which is relatively high in oceanographic terms. As a first of its kind deployment, this system demonstrates the transformative potential of wave energy to power oceanographic instrumentation and extend the endurance of autonomous underwater vehicles.

Keywords— Autonomous Instrumentation, Field Demonstration, Wave Power, Wireless Power Transfer.

I. INTRODUCTION

EARLY adoption of marine energy systems will likely have the greatest impact on markets where the cost of power from alternative sources are relatively high and marine resources are abundant [1]. The United States Department of Energy has identified 11 potential alternative markets for marine energy including ocean observation and underwater vehicle recharge. These markets present a unique opportunity for marine renewable energy, because autonomous oceanographic instrumentation systems typically operate in offshore locations where cabled shore power is either unavailable or prohibitively expensive. As a result, these systems are generally designed to operate on battery power and constrained in deployment duration by reason of cost and logistics. By providing continuous power in these locations, marine energy converters, backed with energy storage, can increase the operational capabilities of autonomous ocean instrumentation and extend deployment durations. The Wave-Powered Adaptable Monitoring Package (or WAMP) is a demonstration of this capability – a wave energy powered environmental monitoring system, the AMP [2] & [3], and a demonstration unit for underwater vehicle recharge [4], [5], & [6].

ID: 1528, Track: Environmental impacts and appraisal.

This work was supported in part by the University of Hawaii contract MA1316, NAVSEA contract N00024-08-D-6323/0016, and the US DOE contract DE-EE0006788 MOD11.

J. B. Joslin is with the Applied Physics Laboratory at the University of Washington, 1013 NE 40th St, Seattle, Washington 98105, U.S.A (e-mail: jbjoslin@apl.washington.edu).

E. D. Cotter is with the Mechanical Engineering Department at the University of Washington, 3900 E Stevens Way, Seattle, Washington 98105, U.S.A (e-mail: ecotter@uw.edu).

P. G. Murphy is with the Mechanical Engineering Department at the University of Washington, 3900 E Stevens Way, Seattle, Washington 98105, U.S.A (e-mail: pgmurphy@uw.edu).

P. J. Gibbs is with the Applied Physics Laboratory at the University of Washington, 1013 NE 40th St, Seattle, Washington 98105, U.S.A (e-mail: gibbsp@apl.washington.edu).

R. J. Cavagnaro is with the Applied Physics Laboratory at the University of Washington, 1013 NE 40th St, Seattle, Washington 98105, U.S.A (e-mail: rcav@apl.washington.edu).

C. Crisp is with the Mechanical Engineering Department at the University of Washington, 3900 E Stevens Way, Seattle, Washington 98105, U.S.A (e-mail: cappy85@uw.edu).

A. R. Stewart is with the Applied Physics Laboratory at the University of Washington, 1013 NE 40th St, Seattle, Washington 98105, U.S.A (e-mail: andy@apl.washington.edu).

B. Polagye is with the Mechanical Engineering Department at the University of Washington, 3900 E Stevens Way, Seattle, Washington 98105, U.S.A (e-mail: bpolagye@uw.edu).

P. S. Cross is with the Hawaii Natural Energy Institute at the University of Hawaii, 1680 East West Road, POST 109, Honolulu, Hawaii 96822, U.S.A (e-mail: pscross@hawaii.edu).

E. Hjetland is with Bolt Sea Power of Fred.Olsen Ltd, Tollbugata 1B, Oslo, Norway (e-mail: evh@fredolsen.com).

A. Rocheleau is with Sea Engineering, 863 N. Nimitz Hwy, Honolulu, Hawaii 96817, U.S.A (e-mail: arocheleau@seaengineering.com).

B. Waters is with WiBotic, 4545 Roosevelt Way NE, Suite 400, Seattle, Washington 98105, U.S.A (e-mail: waters@wibotic.com).

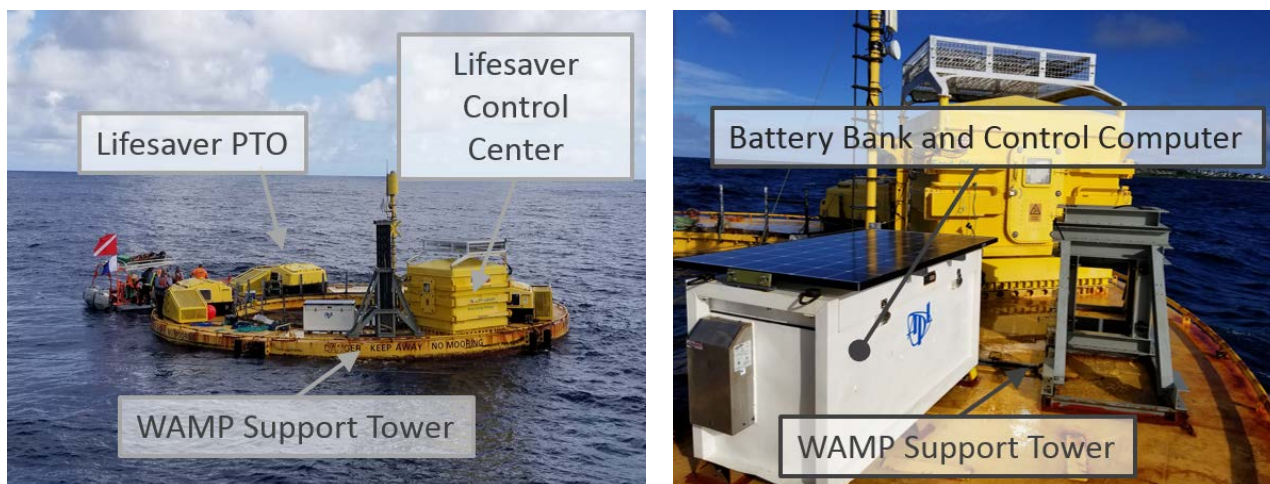

Fig. 1. (a) Lifesaver WEC during deployment at WETS with the WAMP, (b) WAMP components on the deck of the Lifesaver.

The objective of this paper is to present an overview of the WAMP system design, integration with a Fred. Olsen BOLT-class Lifesaver wave energy converter (WEC), operations during deployment, and initial performance results. System design took place over approximately 12 months from October 2017 to October 2018. The subsequent deployment at the 30 m berth of the US Navy Wave Energy Test Site (WETS) in Kane’ohe Bay, HI lasted over 4 months with the system fully operational for 108 days (from October 13th to January 28th). For more information about the site and related deployments, please see [7]. Recovery of the system is scheduled for March 2019 due to contracted dates for the return of the Lifesaver to Europe.

During the deployment, the Lifesaver WEC and WAMP systems operated in a semi-autonomous mode with only a wireless connection to shore for communications and data transfer. Power to the WAMP was managed by an on board micro-grid that combined power from the WEC, a solar panel, and a battery bank. This system powered the on board control computer for data acquisition and processing, the WAMP instrumentation, the demonstration unit for underwater vehicle recharge, and a cooling system. The WAMP is a version of the AMP architecture, an integrated instrumentation approach for performing environmental monitoring around marine energy converters [2]. The instrumentation suite provided continuous monitoring with real-time data processing for target detection and tracking [3]. The primary goal of the WAMP was to capture rare but significant interactions between the WEC and marine animals without altering the environment or accruing a data mortgage. While this paper does not cover the environmental assessment provided by the WAMP data, which is currently ongoing, the description of the system and its capabilities should be useful to future deployments.

II. SYSTEM DESIGN

The Lifesaver WEC, shown in Fig. 1, was developed and operated by Bolt Sea Power of Fred. Olsen Ltd [8] & [9]. After a previous deployment at WETS in 2016, the

Lifesaver was staged dockside in Pearl Harbor. This WEC is a circular point absorber approximately 16 m in diameter with a 10 m open center, 1 m thick hull, and three power take off (PTO) lines that are anchored to the sea floor. In its current configuration, average power output in its nominal design wave state is 30 kW. The hull is assembled from 5 identical pieces that each have a through-hull well to accommodate a PTO winch line. Because only three PTOs were used during this deployment out of a maximum five possible, one of the vacant wells was selected for the integration of the AMP instrumentation. The PTO well allowed for a secure attachment point for the AMP with minimal modification to the WEC. However, mounting the AMP in this way required the design of a custom support tower to position the instruments under the Lifesaver hull and withstand the wave loading. This support tower allowed the instruments to be raised out of the water for towing to the deployment site, lowered to a depth of approximately 2 m once the WEC was deployed, and raised during WEC recovery. The instrument fields of view were oriented to monitor one of the PTO lines.

A. WAMP Deployment Frame and Instrumentation

The WAMP frame was designed to support the wave loading expected during the deployment at WETS while allowing for instrument maintenance. Anodized aluminium with stainless steel fasteners, delrin connectors, and electrical isolation formed the structure of the support tower that holds the instruments and deployment frame that bolts to the Lifesaver deck, as shown in Fig. 2. The instrument tower is approximately 4 m tall with a section 0.6 m by 0.3 m and could be raised and lowered in the mounting frame with a winch and pulley system for maintenance or towing. After the system is lowered, the frame is secured in place and all of the instruments and electronics bottles are below the waterline.

The backbone of the WAMP is the main electronics bottle (MEB) which has 10 controllable instrumentation ports. This bottle, located within the instrumentation frame, receives power at 48 volts from the control box and provides 12, 24, or 48-volt power to each of the instruments

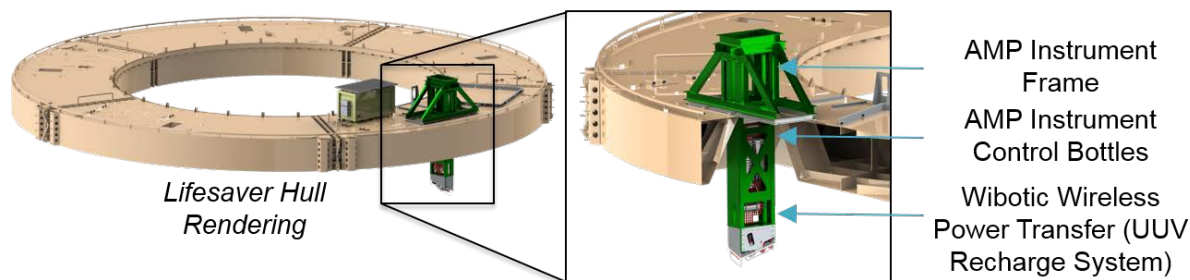

Fig. 2. Integration of the WAMP instrument frame in the Lifesaver Hull.

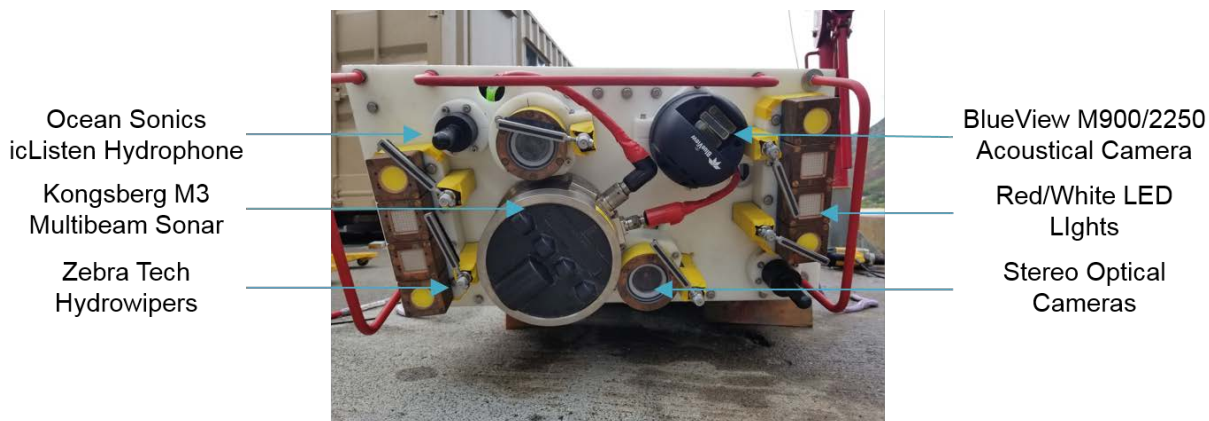

Fig. 3. WAMP instrument head.

as needed. The cable that connects the MEB to the surface control system has 4 fiber optic channels that are converted to Ethernet and serial protocols as needed for each instrument. Fiber optic communication is not required for this transmission distance, but would be for arrangements with a large (i.e., km-scale) separation between the MEB and a control computer. The MEB also monitors currents on each power bus, temperature and humidity within the bottle, and IMU data.

The instrumentation suite selected for the WAMP includes a custom stereo-optical camera pair with strobe light illumination and anti-fouling wipers, a Blueview M900-2250 acoustic camera, a Kongsberg M3 multibeam sonar, two icListen HF smart hydrophones, and the demonstration WiBotic wireless power transfer unit for vehicle recharge. Configuration of the instruments was constrained by the size of the PTO well and the goal of monitoring the adjacent PTO line. Fig. 3 shows the instrument head configuration prior to installation on the WEC.

The optical camera system integrates two Manta G-507 monochromatic machine vision cameras (Allied Vision Technologies) with Kowa LM5JCM lenses housed in custom PVC bottles with planar scratch resistant acrylic view ports [10]. A copper ring around the edge of the view ports helps to mitigate biofouling along with mechanical brush style Hydro-Wipers (Zebra-Tech, Ltd) [11]. Illumination for the optical system is provided by either four white or four far-red (730 nm wavelength) custom built LED lights. The white lights use CREE CXB-3590 LED arrays that produce approximately 13,000 lumens and the red lights use an array of 64 Luminus SST-10-FR LEDs. Like the optical cameras, these lights are protected from

biofouling by a copper housing and mechanical wiper. All of the components of the camera system are connected to a single control bottle that is then connected to the main electronics bottle and operated with Ethernet and RS-232 communications.

The acoustic camera, multibeam sonar, and hydrophones are all off-the-shelf instruments that are connected to the main electronics bottle for power and Ethernet communications.

B. Wireless Power Transfer Unit for Vehicle Recharge

The demonstration unit for underwater vehicle recharge is developed by WiBotic and consists of two bottles that serve as the system transmitter and receiver as shown in Fig. 4. The transmitter is connected to the AMP MEB for 48 VDC power and Ethernet communications and the receiver is mounted with a water gap of approximately 1 cm from the transmitter. The system is capable of transmitting up to 150 W of RF power at 13.56 MHz with high speed Ethernet communications over this water gap. For this demonstration, the receiver is acting as a simple load that charges a battery to run a fan, microprocessor, camera, and wireless communication link. A typical use case for this system would have the receiver built into an underwater vehicle that returns periodically to a docking station to recharge its battery and offload data.

WiBotic's flexible wireless power technology is effective for long-term deployments partly because of its ability to resist the effects of biofouling. Biofouling and changing environmental conditions can cause typical inductive wireless power systems to become de-tuned and degrade, significantly reducing their efficiency. De-tuning of a system leads to excess heat being generated and eventual

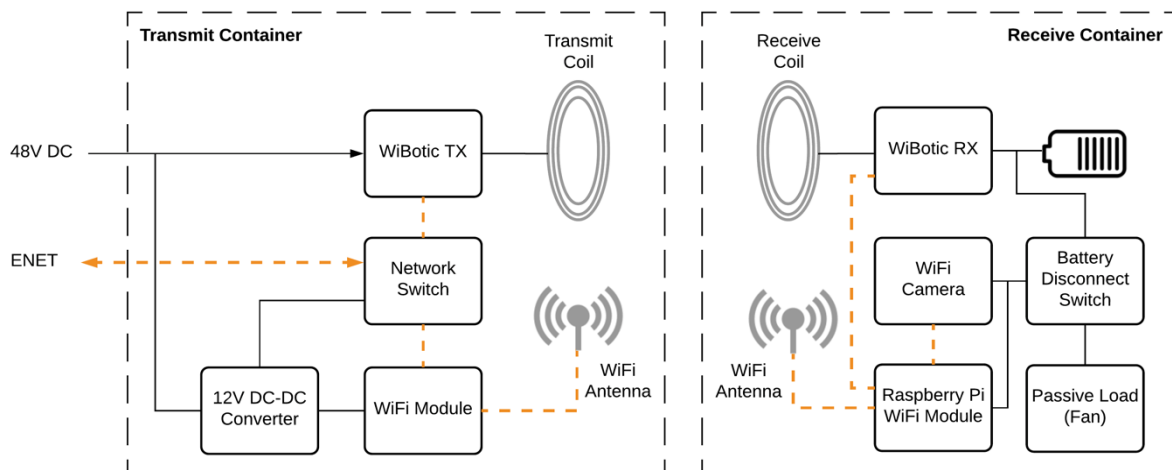

Fig. 4. Block diagram of WiBotic wireless power transfer demonstration unit for underwater vehicle recharge.

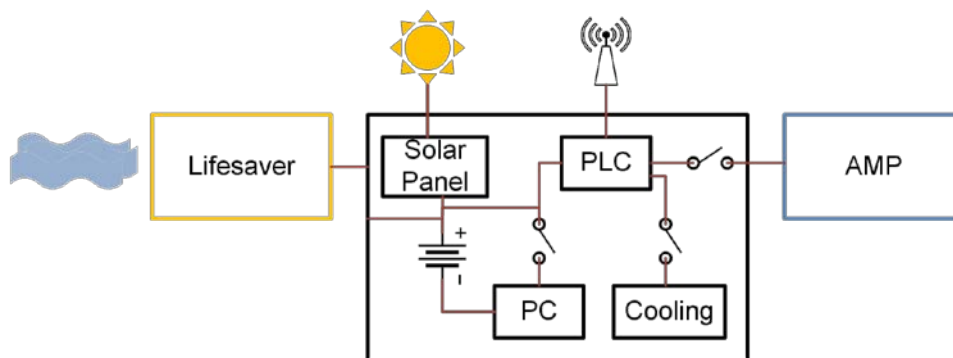

Fig. 5. Block diagram of WAMP control box components.

failure. To address this problem, WiBotic’s adaptive resonant wireless power technology can adapt to variations in distance between transmitter and receiver, dynamic load conditions, and environmental wear and tear.

C. WAMP Control Box

A computer onboard the Lifesaver enables continuous data acquisition, sensor control, and real-time data processing. This computer is housed in a double steel enclosure mounted to the deck of the WEC as shown in Fig. 1b and 5. This box is rectangular and measures approximately 2 x 1 x 1 m and weighs 635 kg. Along with the computer, this deck box houses a Programmable Logic Controller (PLC), the power management system, a backup battery bank, and a cooling system. To protect the sensitive electronics from the external environment, the internal enclosure is sealed and cooled with circulation fans and a 240 W air conditioner. The external enclosure houses the battery bank of 10 Lifeline GPL-31T AGM 12 VDC batteries configured with 2 in parallel and 5 in series to form a 525 Ah 24 VDC bank. Cooling is provided by wash-down fans that circulate external air through this outer enclosure. A 300 W solar panel is mounted to the top of the box to provide shade for the system and power to maintain PLC function during extended periods of calm seas. The PLC controls power to each piece of the system and collects data on the temperature, humidity, current draw, and battery voltage.

This control box is connected to the WEC via two cables; a 24 VDC power cable, and a signal cable that communicates the state of power availability. Two automatic charge relays limit the current draw from the WEC to either a high power (40 amps) or low power (15 amps) state, as indicated by the WECs availability. For communications with shore, a high bandwidth point-to-point wireless link antenna is mounted on the mast of the Lifesaver, as well as a backup Verizon Wireless cellular modem, and a low bandwidth GSM antenna. On shore, the wireless link is connected to a computer that is connected to the internet with back up data storage. The system was operated via a Windows Remote Desktop connection to the shore computer.

D. System Operations

The BOLT Lifesaver operated autonomously on parameters set over the internet by operators at the Fred. Olsen headquarters in Oslo, Norway. The Lifesaver could typically maintain power production in significant wave heights above 0.6 m, depending on wave periods. Depending on conditions for power production, Lifesaver autonomously switched between three power management modes. The algorithm estimated conditions using calculated aggregates from several system parameters. Power for the system controller (National Instruments cRio PLC) and communication equipment (4G and radio link) was always highest priority.

In Normal Power Mode, all on-board systems were allowed their nominal power draw, including the WAMP

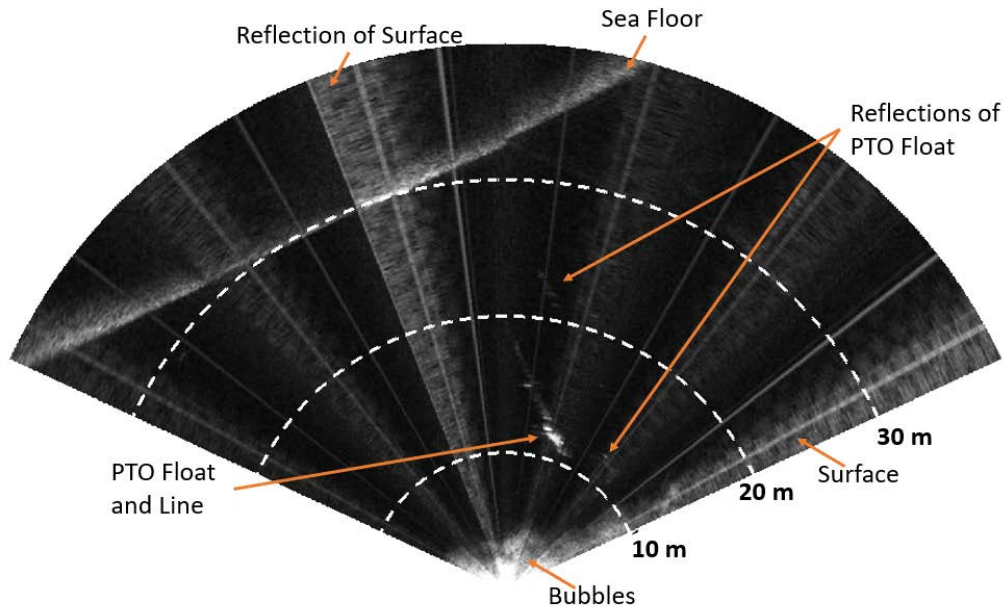

Fig. 6 Sample image from the Blueview acoustic camera, highlighting persistent signals in the sonar image. The radial lines in the image are the result of beam overlap (minimized by sounds speed tuning) and electrical noise from other AMP sensors.

up to 1200 W (40 A @ 28.8 V). In Low Power Mode, auxiliary systems such as surveillance cameras and coolant pumps were put on duty cycles to save power, and WAMP power draw was restricted to 300 W (10 A @ 28.8 V). In Critical Low Power mode, the WAMP power export was disabled and only controller and communication equipment were allowed power (power generation so low generator cooling was not required). Generated power that was not consumed by any system on-board was dissipated in on-board heat resistors.

If the Lifesaver determined power production was too low for surplus generation, either due to low wave state or system failures, she entered Sleep Mode. In this mode, only a timer was allowed to draw power from the battery bank. Once every hour, communication equipment and an internal MRU was switched on. The MRU logged motion of the structure as a means to estimate wave conditions. If conditions were identified as too low for surplus generation, Lifesaver went back to sleep for another hour. If conditions were found to allow surplus generation, production was initiated.

The WAMP was controlled by a combination of the PLC, AMP computer, and shore computer. Approximately 500 W of power were needed for continuous operation of the full WAMP system: 180 W for the computer, 120 W for the instrumentation, and 200 W for cooling. When the WiBotic system was transferring power an additional 100 W were required. While the voltage of the battery bank was above a low voltage set point (typically 24 VDC), the AMP computer and instrumentation were on and continuously acquiring and processing data. If the temperature in the internal enclosure exceeded 32 degrees C, the cooling system turned on until the temperature dropped below 28° C. If the battery bank voltage dropped below the set point or the temperature climbed above high set point (45° C), then the computer turned off the AMP and shut itself down to enter a low power mode.

In the low power mode, the system required approximately 40 W to run the PLC and radio link, which could typically be maintained by solar power if wave power was not available. As a backup for extreme low power conditions, the GSM modem could be remote-controlled to turn off the PLC to conserve battery power. In this state the solar power would recharge the battery bank but the PLC would stop acquiring health monitoring data on the system.

For manual system control or data transfer, the operator could login via a secure remote desktop connection over the radio link or via the GSM modem. Continuous monitoring of the system operations and health via the GSM modem were enabled by a custom mobile application (Blynk).

Instrument control and data acquisition were implemented on the AMP computer in LabVIEW (National Instruments). Each sensor and subsystem was controlled in an individual module, so that the software was robust in the event of sensor failure (e.g., if one sensor malfunctioned, the rest of the system would operate as normal). Each sensor control module handled both inbound and outbound communication with the sensor (e.g., modify sensor parameters and read data from the instrument).

Continual archival of these data streams would produce over 800 GB each day, a volume which was infeasible to store on the Lifesaver platform or transfer over the radio link. Further, even if continual archival were feasible, this would be challenging to post-process for analysis. Therefore, data were only written to disk when a command was generated, either on a programmed duty cycle (e.g., archive data from all sensors once every 15 minutes), by a human user, or when a target was automatically detected in the sonar data. Data from all sensors were continually stored in 60 second ring buffers (i.e., newest data overwrites the oldest). The ring buffer

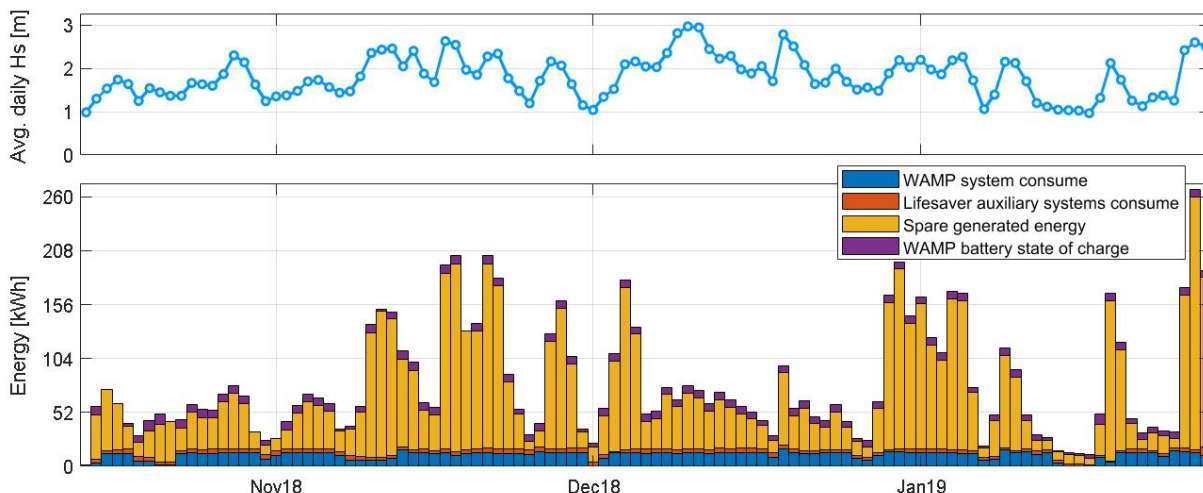

Fig. 7 Average daily wave height and Lifesaver power production for the full deployment.

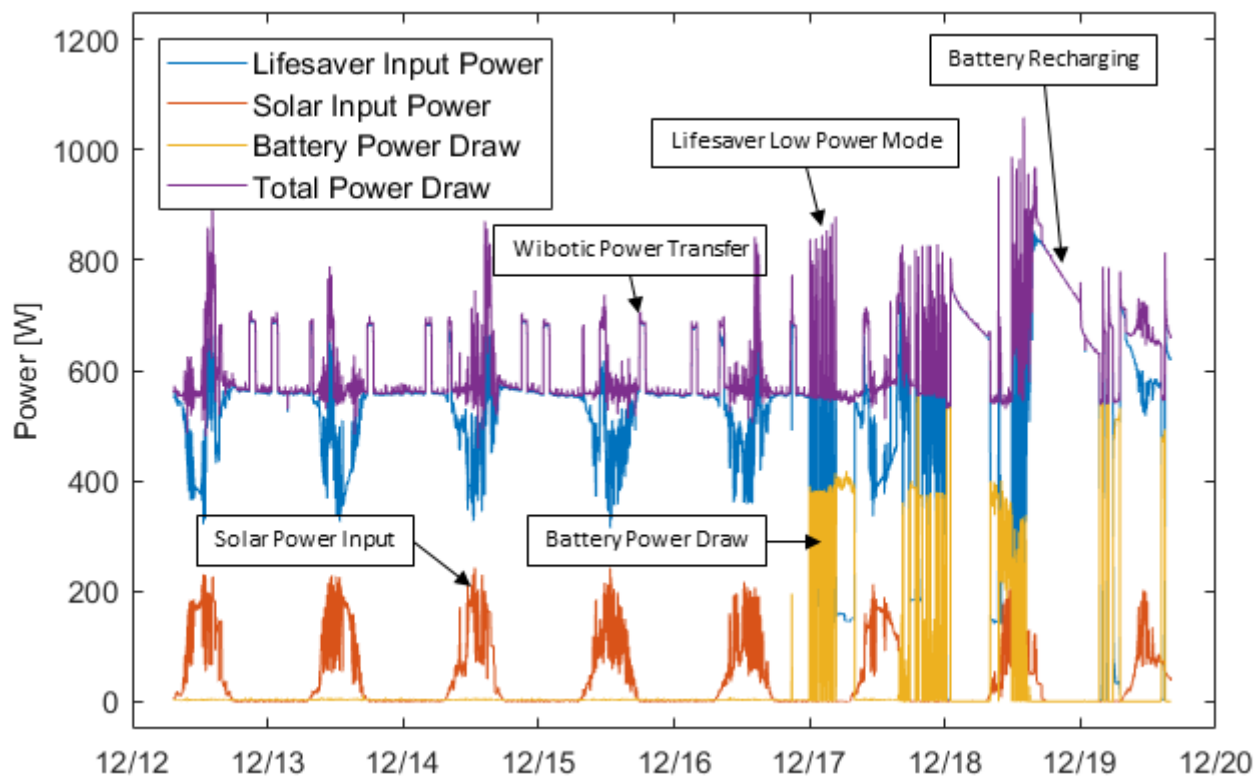

Fig. 8 Example of WAMP power inputs and draws for one week of deployment.

architecture meant that data from both before and after an archival command was generated could be stored to disk, because 60 seconds of data were always in memory. Additionally, the temporary ring buffer storage meant that any automatic processing algorithms did not need to operate in real-time, as long as they could operate at the same rate as data acquisition.

Real-time target detection and tracking were initially implemented in MATLAB (Mathworks) following the methods detailed in [3]. However, as shown in Fig. 6, the persistent presence of the seafloor, water surface, and PTO float and line in the image complicated implementation. The position, shape, and intensity of these targets and their reflections varied with sonar position, indicating that image registration was necessary before background

subtraction. Additionally, in strong waves (> 2 m significant wave height), bubbles occasionally attenuated the sonar ping, and no targets were visible. Research to address these challenges and automatically detect and classify targets in the WAMP sonar data is ongoing.

III. RESULTS

Commissioning of the WAMP occurred in several stages starting with initial system testing in a salt water tank at the University of Washington. The WAMP was then shipped to Hawaii in July, 2018 and assembled for further dockside testing prior to installation on the Lifesaver in Pearl Harbor. Due to the weather restrictions, deployment operations of the Lifesaver did not begin until October 4th, 2018 when the WEC was towed from Pearl Harbor to

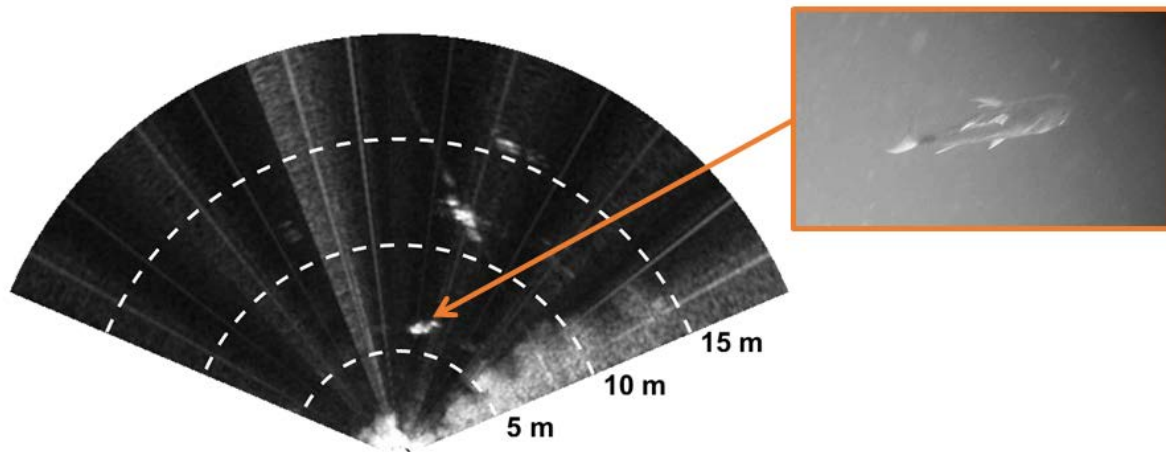

Fig. 9 Example acoustic (on the left) and optical (on the right) data showing a large fish target.



Fig. 10 Underwater view of the WAMP with fish schooling around the structure.

WETS. Initial installation of the mooring system was completed the following day and the WAMP tower was lowered and secured for deployment with the system in low-power mode. The mooring system was completed the following week and after an initial charge of the battery bank, the WAMP became fully operational on October 13th.

E. Operating Conditions and System Uptime

BOLT Lifesaver maintained power production uninterrupted throughout the deployment period and generated a total of 8,000 kWh, as shown in Fig. 7. Some operational failures occurred. Winch line rock bolt anchors were pulled out of the ground twice and broken off once. Winch line failures occurred twice. In addition, one instance of coolant pump failure occurred. Because of redundancy in the three PTO setup, none of these failures caused downtime on power production.

Throughout the deployment the WAMP control system, power management system, radio link, cooling system, and solar panel ran autonomously. The power management system handled the inputs from the WEC and solar panel to maintain the battery bank charge without the use of the extreme low power mode. The

cooling system similarly maintained operational temperatures without requiring the system to shut down. Typical operating conditions at WETS resulted in control box enclosure temperatures of 38 and 32° C for the internal and external enclosures, respectively. The battery bank voltage floated at approximately 27 VDC when receiving charge from the WEC and was able to power the full system for approximately 18 hours without input from the WEC before switching to low power mode.

During the deployment, the WEC supplied over 1,152 kWh of power to the WAMP. The WEC stopped providing power to the WAMP for more than one minute 120 times due to low power production. However, because of the battery bank and solar panel, the WAMP only switched to low power mode for 37 of these interruptions. Fig. 8 shows an example of the input and output power profile from one week of the deployment. Towards the end of this week, the battery bank provided power when wave and solar power were insufficient to power the system. In total, the WAMP control system was operational for 100% of the 108-day deployment, and the monitoring instrumentation and computer were operational for 84% of the deployment (the system was in low-power mode for the remaining 16% of the deployment).

F. Monitoring System Performance

As with the low level controls, the LabVIEW and MATLAB software were fully operational for the entire deployment, with the exception of planned outages for software upgrades. Fish schools, individual fish, and sea turtles were identified in the optical camera and sonar data. A sample of a fish observed in the acoustic camera and optical cameras is shown in Fig. 9. Small tropical reef fish were nearly continually observed in the optical camera imagery schooling around the WAMP structure as shown in Fig. 10.

G. Wireless Power Transfer System Performance

Data collected during the deployment demonstrated the durability of WiBotic's technology and showed that it is capable of delivering consistent undersea power for

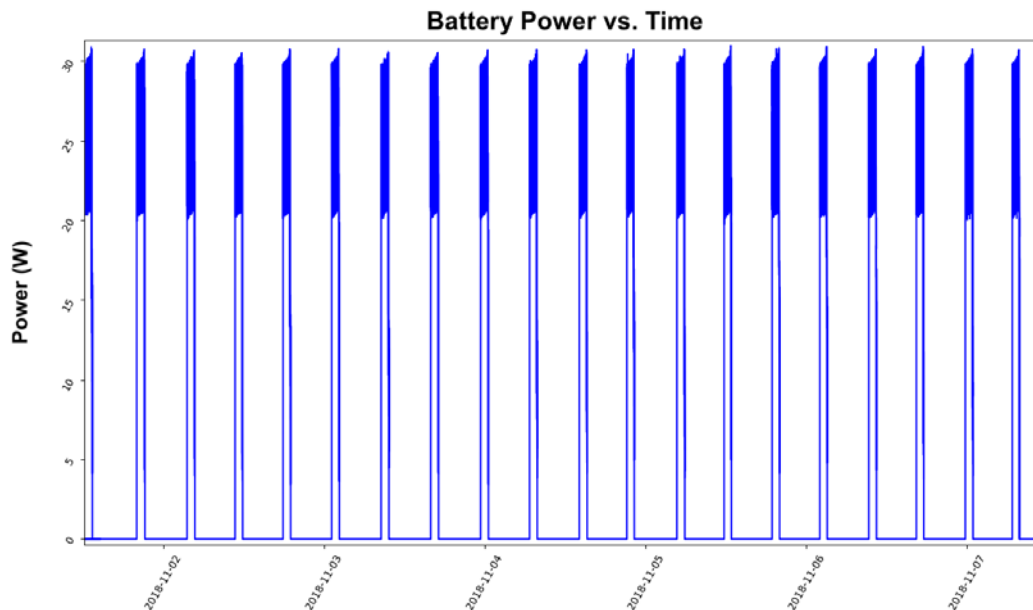

Fig. 11 Example of wireless power transfer during one week of deployment.

extended periods of time. Fig. 11 shows the power delivered to the receiver housing during a typical week in November. Power was transferred reliably at regular intervals and at consistent levels. The WiBotic on board charger operated in a constant-current constant-voltage charge cycle. For the first ~60 minutes of charging, the power delivered to the battery remained relatively constant (constant current). The slight oscillations were due to the WiBotic adaptive tuning. As the water level changed with waves, the system adapted to changing conditions while attempting to keep power delivery constant.

IV. DISCUSSION

Integration of the AMP with the Lifesaver WEC proved a highly successful demonstration of marine energy providing power to autonomous oceanographic instrumentation and wireless power transfer systems. This project was executed on a relatively short timeline with the goal of maintaining autonomous operations over a multi-month deployment. Given the performance of each of the system components, this goal was achieved with many lessons learned to guide future deployments of this type.

H. BOLT Lifesaver Performance

Three major changes were implemented to the Lifesaver system ahead of this deployment. Generator torque control software was updated to allow torque settings to float more continuously within predefined ranges. The motivation was to increase the amount of time generator control is optimized for the current wave climate.

Secondly, power export infrastructure on the 24 V system was incorporated, which also prompted an upgrade of the power management software. Such a system must regulate on-supply (renewable) power for an on demand application. These two changes could

ultimately only be tested once the whole system was on site and operation. Hence, certain functions, for instance WAMP power export, had to be implemented stepwise as operation started. By mistake, on a few occasions in late October through early November, the WAMP was not allowed nominal power draw despite abundant power production, which lead to unnecessary WAMP downtime.

However, it was decided to build a “digital twin” software to emulate the incoming and exported power flow, which proved very useful for testing during development, and greatly reduced risk of failures once the trials started.

Thirdly, a new mooring line product to connect the winch lines to seabed was used. A fiber tether product replaced fiber ropes used previously, in anticipation that it would provide a stiffer connection between the winch drum and the seabed, hence increase efficiency in energy absorption by the PTO units. However, instead power production proved to be lower than with the previous mooring design, and data analysis indicate the fiber tethers were actually softer than the ropes. Investigation of these observations is on-going.

I. WAMP Performance

Although the WAMP remained operational for the entire deployment, there were many lessons learned and challenges overcome. Retrospectively, early decisions in the design process could have reduced the level of customization in the instrument frame if the AMP was positioned over the side of the WEC instead of through the hull. Development of the power management system required several iterations with the Fred.Olsen team and could not be fully tested until installation on the Lifesaver. Similarly, the cooling system design for the control box could only be effectively tested at the deployment site given the heat and humidity in Hawaii. As with any demonstration deployment, permitting timeframes were

also unpredictable and required extensive effort on the part of the University of Hawaii and the US Navy. Finally, as is often the case with deployments at marine energy sites, operations that require calm weather conditions can be difficult to manage and require extra flexibility of the deployment crews.

For the monitoring system, the motion of the Lifesaver platform and the presence of the Lifesaver PTO float and line complicated automated processing of the WAMP sonar data. This meant that methods developed for real-time processing of data from the same sensor suite on a static platform without any persistent targets in the field of view [3] required significant modification. Ongoing software development is focused on automatic removal of persistent targets and their reflections as well as surface interference in the multibeam sonar data.

Future optimization of the WAMP is possible through system refinements. Alternative instrument configurations could allow for monitoring of other features of the WEC. A more efficient power system could be developed using the system data collected during this deployment to increase system up time and enable deployments in a wide range of wave climates.

V. CONCLUSION

Powering the AMP with wave energy from the Lifesaver WEC enabled continuous environmental monitoring with operational time comparable to previous deployments with a grid power connection [3]. Overall, this deployment was highly successful with many challenges overcome and lessons learned that will facilitate future deployments. The ongoing effort to improve real-time target detection, tracking, and classification methods are reliant on deployments such as this to build understanding and collect training data sets. Further deployments of this type are required to build confidence in the adoption of these systems in maritime markets.

ACKNOWLEDGEMENT

This project has been possible through the collaboration of researchers and industry partners at the University of Washington, University of Hawaii, Fred. Olsen Ltd., WiBotic Inc., and Sea Engineering. The authors would like to acknowledge the contributions of Cory Luker, Patrick Anderson, Jonas Sjotle, Chasen Smith, Alex Huttunen and George Nuesca, without which this system would never have been completed on time and the deployment would not have been such a success.

REFERENCES

- [1] A. Copping, A. LiVecchi, H. Spence, A. Gorton, S. Jenne, R. Preus, G. Gill, R. Robichaud, & S. Gore, "Maritime renewable energy markets: power from the sea," *Marine Tech. Soc. J.*, 52(5), pp. 99-109., 2018.
- [2] J. Joslin, B. Polagye, & A. Stewart, "Development of an adaptable monitoring package for marine renewable energy," In *5th Int. Conf. on Ocean Energy*, Halifax, NS, Canada, 2014.
- [3] E. Cotter, P. Murphy, & B. Polagye, "Benchmarking sensor fusion capabilities of an integrated instrumentation package," *Int. J. of Marine Energy.*, 2017
<https://doi.org/10.1016/j.ijome.2017.09.003>.
- [4] A. P. Sample, B. H. Waters, S. T. Wisdom, & J. R. Smith, "Enabling seamless wireless power delivery in dynamic environments," *Proc. IEEE*, 101(6), pp. 1343-1358., June 2013.
- [5] B. H. Waters, B. Mahoney, V. Ranganathan, & J. R. Smith, "Power delivery and leakage field control using and adaptive phased array wireless power system," *IEEE Trans. Power Electronics, Spec. Is. on Wireless Power Transfer*, February 2013.
- [6] A. P. Sample, & J. R. Smith, "Experimental results with two wireless power transfer systems," In *IEEE Radio and Wireless Symposium*, 2009.
- [7] P. Cross, K. Rajagopalan, A. Druetzler, A. Stewart, R. Cavagnaro, J. Joslin, E. Hjetland, J. Sjolte, A. Argyros. "Recent Developments at the U.S. Navy Wave Energy Test Site," *EWTEC*, Naples, Italy, 2019.
- [8] J. Sjolte, *Marine renewable energy conversion: grid and off-grid modeling, design and operation*, Ph.D. dissertation, Norges teknisk-naturvitenskapelige universitet, Fakultet for informasjonsteknologi, matematikk og elektroteknikk, Institutt for elkraftteknikk, Norway, 2014,
<http://hdl.handle.net/11250/257868>.
- [9] "NAVFAC EXWC supports successful test of wave energy converter powering oceanographic instrumentation", NAVFAC EXWC Public Affairs, NNS181108-08, Nov. 2018,
https://www.navy.mil/submit/display.asp?story_id=107695.
- [10] J. Joslin, B. Polagye, & S. Parker-Stetter, "Development of a stereo-optical camera system for monitoring tidal turbines" *SPIE J. of Applied Remote Sensing*, 8(1), 083633-1-25, 2014,
<https://doi.org/10.1117/1.JRS.8.083633>.
- [11] J. Joslin, & B. Polagye, "Demonstration of biofouling mitigation methods for long-term deployments of optical cameras," *Marine Tech. Soc. J.*, 49(1), 2016,
<https://doi.org/10.4031/MTSJ.49.1.12>.